

<b>International Association Of Certified Practicing Engineers</b>	 <b>www.iacpe.com</b> <b>Knowledge, Certification, Networking</b>	<b>Page : 1 of 151</b>
		<b>Rev: 02</b>  <b>Rev 01 - July 2014</b> <b>Rev 02 - Jan 2015</b>
<b>IACPE</b> No 19, Jalan Bilal Mahmood 80100 Johor Bahru Malaysia	<b>ENGINEERING MATERIALS AND THEIR STRENGTH</b>  <b>CPE LEVEL I TRAINING MODULE</b>	

The International Association of Certified Practicing Engineers is providing the introduction to the Training Module for your review.

We believe you should consider joining our Association and becoming a Certified Practicing Engineer. This would be a great option for engineering improvement, certification and networking.

This would help your career by

1. Providing a standard of professional competence in the practicing engineering and management field
2. Identify and recognize those individuals who, by studying and passing an examination, meets the standards of the organization
3. Encourage practicing engineers and management professionals to participate in a continuing program of personal and professional development

**www.IACPE.com**

<b>International Association Of Certified Practicing Engineers</b>	<b>ENGINEERING MATERIALS AND THEIR STRENGTH</b>	Page 2 of 151
		Rev: 02
		Jan 2015

## TABLE OF CONTENT

<b>INTRODUCTION</b>	<b>9</b>
<b>Scope</b>	<b>9</b>
<b>General Considerations</b>	<b>10</b>
<b>I.    Material Standards and Specifications</b>	<b>10</b>
<b>II.   Engineering Material</b>	<b>11</b>
<b>III.  Mechanical Behaviors and Properties of Materials</b>	<b>12</b>
<b>A.  Stress and Strain Behaviours</b>	<b>12</b>
<b>B.  Fatigue</b>	<b>14</b>
<b>C.  Creep</b>	<b>14</b>
<b>D.  Hardness</b>	<b>15</b>
<b>DEFINITIONS</b>	<b>16</b>
<b>NOMENCLATURE</b>	<b>18</b>
<b>Greek Letter</b>	<b>19</b>
<b>THEORY</b>	<b>20</b>
<b>I.    Engineering Materials</b>	<b>20</b>
<b>A.  Metals</b>	<b>20</b>
<b>B.  Polymers</b>	<b>36</b>
<b>C.  Ceramics</b>	<b>59</b>
<b>D.  Composites</b>	<b>76</b>
<b>II.   Strength of Materials</b>	<b>97</b>
<b>A.  Stress and Strain – Axial Loading</b>	<b>97</b>

<b>International Association Of Certified Practicing Engineers</b>	<b>ENGINEERING MATERIALS AND THEIR STRENGTH</b>	Page 3 of 151
		Rev: 02
		Jan 2015

<b>B. Torsion</b>	<b>101</b>
<b>C. Shear Forces and Bending Moments</b>	<b>111</b>
<b>D. Pure Bending</b>	<b>119</b>
<b>E. Transformation of Stress</b>	<b>122</b>
<b>F. Applications of Stresses in Mechanical Elements</b>	<b>128</b>
<b>G. Fatigue</b>	<b>141</b>
<b>H. Hardness</b>	<b>147</b>

## **REFERENCES**

### **LIST OF TABLE**

<b>Table 1: properties of grey irons</b>	<b>21</b>
<b>Table 2 : properties of SG iron</b>	<b>21</b>
<b>Table 3 : properties of carbon steels</b>	<b>23</b>
<b>Table 4 : concentration limits of elements for alloy steel</b>	<b>24</b>
<b>Table 5 : typical properties of alloy steels</b>	<b>26</b>
<b>Table 6 : mechanical properties of copper alloys</b>	<b>28</b>
<b>Table 7 : mechanical properties of an aluminium casting alloys</b>	<b>29</b>
<b>Table 8 : example of plastic specification</b>	<b>37</b>
<b>Table 9 : numbers on plastic</b>	<b>38</b>
<b>Table 10: U.S Plastics sales and Applications (1988)</b>	<b>38</b>
<b>Table 11 : types of copolymers from monomers</b>	<b>43</b>
<b>Table 12 : classification of crystalline polymers</b>	<b>48</b>
<b>Table 13 : friction coefficient</b>	<b>57</b>
<b>Table 14 : classification of high-technology ceramics based on the functions</b>	<b>61</b>

<b>International Association Of Certified Practicing Engineers</b>	<b>ENGINEERING MATERIALS AND THEIR STRENGTH</b>	Page 4 of 151
		Rev: 02
		Jan 2015

<b>Table 15 : characterization of two clay-based</b>	<b>63</b>
<b>Table 16 : mechanical properties of ceramic materials</b>	<b>64</b>
<b>Table 17 : melting points of ceramic oxides</b>	<b>65</b>
<b>Table 18 : thermal expansion coefficient</b>	<b>66</b>
<b>Table 19 : resistivity values</b>	<b>66</b>
<b>Table 20: properties of advanced ceramics</b>	<b>67</b>
<b>Table 21 : fracture strength vs flaw size</b>	<b>69</b>
<b>Table 22 : efficiency of fiber reinforcement</b>	<b>85</b>
<b>Table 23 : effect of fiber orientation to mechanical properties</b>	<b>91</b>
<b>Table 24 : stresses in knuckle joint</b>	<b>129</b>
<b>Table 25: bolts size</b>	<b>133</b>
<b>Table 26 : value of constant c against to number of spokes</b>	<b>140</b>
<b>Table 27 : endurance limit for some steels</b>	<b>145</b>
<b>Table 28 : wrought aluminium alloys</b>	<b>145</b>
<b>Table 29 : effect of surface finish</b>	<b>146</b>

#### **LIST OF FIGURE**

<b>Figure 1 : stress types</b>	<b>12</b>
<b>Figure 2 : stress-strain curve</b>	<b>13</b>
<b>Figure 3 : influence of Cr content</b>	<b>32</b>
<b>Figure 4 : manufacturing process for iron and steel</b>	<b>36</b>
<b>Figure 5 : linear polymers</b>	<b>41</b>
<b>Figure 6 : types of branched polymers</b>	<b>41</b>
<b>Figure 7 : crosslinked polymers</b>	<b>42</b>

<b>International Association Of Certified Practicing Engineers</b>	<b>ENGINEERING MATERIALS AND THEIR STRENGTH</b>	Page 5 of 151
		Rev: 02
		Jan 2015

<b>Figure 8 : network polymers</b>	<b>42</b>
<b>Figure 9 : Homopolymer Structures</b>	<b>43</b>
<b>Figure 10 : addition polymers</b>	<b>44</b>
<b>Figure 11 : condensation polymers</b>	<b>45</b>
<b>Figure 12 : Logarithm of the elastic modulus versus temperature</b>	<b>47</b>
<b>Figure 13 : Shear Modulus vs Temperature</b>	<b>49</b>
<b>Figure 14 : Stress vs Strain</b>	<b>49</b>
<b>Figure 15 : temperature dependence of shear modulus (G)</b>	<b>51</b>
<b>Figure 16: stress-strain curve for thermosets</b>	<b>51</b>
<b>Figure 17 : shear modulus vs temperature (2)</b>	<b>52</b>
<b>Figure 18 : stress vs strain curve for elastomers</b>	<b>52</b>
<b>Figure 19 : influence of orientation</b>	<b>58</b>
<b>Figure 20: Weibull Plot</b>	<b>70</b>
<b>Figure 21 : temperature's effect</b>	<b>71</b>
<b>Figure 22 : schematic diagram of pressing and blowing processes</b>	<b>75</b>
<b>Figure 23 : slip casting</b>	<b>76</b>
<b>Figure 24 : dispersed phase geometry</b>	<b>77</b>
<b>Figure 25 : modulus of elasticity versus volume percent</b>	<b>80</b>
<b>Figure 26 : continuous and discontinuous fibers</b>	<b>82</b>
<b>Figure 27 : pultrusion and prepreg production process</b>	<b>88</b>
<b>Figure 28 : laminar composite</b>	<b>89</b>
<b>Figure 29 : sandwich structure</b>	<b>90</b>
<b>Figure 30 : configuration of composite lay-up</b>	<b>91</b>
<b>Figure 31 : thermomechanical process</b>	<b>93</b>

<b>International Association Of Certified Practicing Engineers</b>	<b>ENGINEERING MATERIALS AND THEIR STRENGTH</b>	Page 6 of 151
		Rev: 02
		Jan 2015

<b>Figure 32 : In-situ preparation</b>	<b>93</b>
<b>Figure 33 : thermal expansion of typical ceramics</b>	<b>96</b>
<b>Figure 34 : elastic modulus effect</b>	<b>97</b>
<b>Figure 35 : deformation of axially-loaded bar</b>	<b>98</b>
<b>Figure 36 : transmission shaft</b>	<b>101</b>
<b>Figure 37 : shaft to torque</b>	<b>102</b>
<b>Figure 38 : shaft with fixed support</b>	<b>103</b>
<b>Figure 39 : comparison of deformations in circular and square shafts</b>	<b>103</b>
<b>Figure 40 : shearing strain</b>	<b>104</b>
<b>Figure 41 : distribution of shearing stress</b>	<b>105</b>
<b>Figure 42 : multiple sections and multiple torque</b>	<b>107</b>
<b>Figure 43 : sign conventions for torque and angle of twist</b>	<b>107</b>
<b>Figure 44 : solid circular shaft</b>	<b>108</b>
<b>Figure 45 : hollow circular shaft</b>	<b>109</b>
<b>Figure 46 : rectangular bar</b>	<b>110</b>
<b>Figure 47 : thin tubular section</b>	<b>111</b>
<b>Figure 48 : types of beams</b>	<b>112</b>
<b>Figure 49 : types of loads</b>	<b>113</b>
<b>Figure 50 : distributed loads</b>	<b>113</b>
<b>Figure 51 : cantilever beam</b>	<b>115</b>
<b>Figure 52 : sign conventions for shear force V and bending M</b>	<b>116</b>
<b>Figure 53 : example force and bending moment diagram</b>	<b>116</b>
<b>Figure 54 : small beam element in bending</b>	<b>119</b>
<b>Figure 55 : beam section cut</b>	<b>120</b>

<b>International Association Of Certified Practicing Engineers</b>	<b>ENGINEERING MATERIALS AND THEIR STRENGTH</b>	Page 7 of 151
		Rev: 02
		Jan 2015

<b>Figure 56 : bending stress</b>	<b>121</b>
<b>Figure 57 : element in plane stress</b>	<b>123</b>
<b>Figure 58 : an oblique plane</b>	<b>123</b>
<b>Figure 59 : Mohr's circle application</b>	<b>127</b>
<b>Figure 60 : stress due to the falling mass</b>	<b>128</b>
<b>Figure 61 : stress due to the moving part</b>	<b>128</b>
<b>Figure 62: Hexagonal head bolt</b>	<b>131</b>
<b>Figure 63: Square head bolt</b>	<b>131</b>
<b>Figure 64: Stud bolt</b>	<b>132</b>
<b>Figure 65: Slotted nut</b>	<b>132</b>
<b>Figure 66 : Castle nut</b>	<b>132</b>
<b>Figure 67: Hexagonal socket head screw</b>	<b>132</b>
<b>Figure 68: helical spring lock washer</b>	<b>132</b>
<b>Figure 69: two-coil spring lock washer</b>	<b>132</b>
<b>Figure 70 : bolted joint in tension</b>	<b>133</b>
<b>Figure 71 : butt Weld</b>	<b>135</b>
<b>Figure 72 : fillet weld with parallel loading</b>	<b>136</b>
<b>Figure 73: fillet weld with transverse loading</b>	<b>136</b>
<b>Figure 74 : thin ring</b>	<b>137</b>
<b>Figure 75: solid disk</b>	<b>138</b>
<b>Figure 76 : annular wheel</b>	<b>138</b>
<b>Figure 77: spoked wheel</b>	<b>139</b>
<b>Figure 78 : fluctuating stresses</b>	<b>141</b>
<b>Figure 79 : alternating stress</b>	<b>142</b>

<b>International Association Of Certified Practicing Engineers</b>	<b>ENGINEERING MATERIALS AND THEIR STRENGTH</b>	<b>Page 8 of 151</b>
		<b>Rev: 02</b>
		<b>Jan 2015</b>
<b>CPE LEVEL I TRAINING MODULE</b>		

<b>Figure 80 : repeated stress</b>	<b>143</b>
<b>Figure 81 : combined steady an alternating stress</b>	<b>143</b>
<b>Figure 82 : endurance limit curve</b>	<b>144</b>
<b>Figure 83 : example of incomplete penetration</b>	<b>146</b>
<b>Figure 84 : example of preferred welds</b>	<b>146</b>

<b>International Association Of Certified Practicing Engineers</b>	<b>ENGINEERING MATERIALS AND THEIR STRENGTH</b>	Page 9 of 151
		Rev: 02
		Jan 2015
<b>CPE LEVEL I TRAINING MODULE</b>		

## **INTRODUCTION**

### **Scope**

Many times, a materials problem is one of selecting the right material from the many thousands that are available. There are several criteria on which the final decision is normally based. The in-service conditions must be characterized, for these will dictate the properties required of the material. On only rare occasions does a material possess the maximum or ideal combination of properties. Thus, it may be necessary to trade off one characteristic for another.

Strength of materials is a general expression for the measure of capacity of resistance possessed by solid masses or pieces of various kinds to any causes tending to produce in them a permanent and disabling change of form or positive fracture.

Strength of materials deals with the relations between the external forces applied to elastic bodies, and the resulting deformations and stresses. In the design of structures and machines, the application of the principles of strength of materials is necessary if satisfactory materials are to be utilized and adequate proportions obtained to resist functional forces.

Strengths are the magnitudes of stresses at which something of interest occurs, such as the proportional limit, 0.2 percent-offset yielding, or fracture. In many cases, such events represent the stress level at which loss of function occurs.

This Training Module provides an overview one of the basic fundamentals of engineering. The knowledge of the types of engineering materials and the strength of those materials is essential to construct safe process equipment. This module will help develop the basics of material choices, and their underlying strength.

A wealth of information can be established by looking at the structures of a material. Engineering Materials is the study of information about materials that in general have been used in many industrial applications such as Irons, Carbon Steels, Alloy Steels, Stainless Steel, Non – Ferrous Metals, Plastics, Composites, and Ceramics. The strengths and weaknesses, corrosion, and when to utilize these materials is very important.

<b>International Association Of Certified Practicing Engineers</b>	<b>ENGINEERING MATERIALS AND THEIR STRENGTH</b>	Page 10 of 151
		Rev: 02
		Jan 2015
<b>CPE LEVEL I TRAINING MODULE</b>		

## **General Considerations**

### **I. Material Standards and Specifications**

A standard is a document, definition, or reference artifact intended for general use by as large a body as possible, a specifications, which involves similar technical content and similar format, usually is limited in both its intended applicability and its users.

Standards have been a part of technology since building began. Standardization minimizes diversity, assures acceptability of products, and facilitates technical communication. There are many attributes of materials that are subject to standardization in example : Composition, Physical Properties, Mechanical Properties and etc.

However, a specification is defined as 'a document intended primarily for use in procurement which clearly and accurately describes the essential technical requirements for items, materials, or services including the procedures by which it will be determined that the requirements have been met'. A second definition defines a specification as 'a source statement of a set of requirements to be satisfied by product, a material or a process indicating whenever appropriate, the procedure by means of which it may be determined whether the requirements given are satisfied.

Noted that :

- (1) A specification may be standard, a part of standard, or independent of a standard,
- (2) As far as practicable, it is desired that the requirements are expressed numerically in terms of appropriate units, together with their limits.'

The objectives of standardization are;

1. Economy of production by way of economies of scale in output, optimization of varieties in input material,
2. Improved managerial control, assurance of quality,
3. Improvement of interchangeability,
4. Facilitation of technical communication,
5. Enhancement of innovation and technological progress
6. Promotions of the safety persons, goods, and the environment.

<b>International Association Of Certified Practicing Engineers</b>	<b>ENGINEERING MATERIALS AND THEIR STRENGTH</b>  <b>CPE LEVEL I TRAINING MODULE</b>	Page 11 of 151
		Rev: 02
		Jan 2015

Material specifications may be classified as to whether they are applied to the material, the process by which it is made, or the performance or use that is expected of it.

## II. Engineering Material

Materials that are used as raw material for any sort of construction or manufacturing in an organized way of engineering application are known as Engineering Materials. The most convenient way to study the properties and uses of engineering materials is to classify them into families of material that are described as follow :

### A. Metals

Materials in this group are composed of one or more metallic elements (such as iron, aluminum, copper, titanium, gold, and nickel), and often also nonmetallic elements (for example, carbon, nitrogen, and oxygen) in relatively small amounts. With regard to mechanical characteristics, these materials are relatively stiff and strong, yet are ductile, and are resistant to fracture, which accounts for their widespread use in structural applications<sup>[7]</sup>.

### B. Ceramics

Ceramics are compounds between metallic and nonmetallic elements; they are most frequently oxides, nitrides, and carbides. In addition, those also composed of clay minerals (i.e., porcelain), as well as cement, and glass. With regard to mechanical behavior, ceramic materials are extremely brittle (lack ductility), and are highly susceptible to fracture. Despite this, they have attractive features. They are stiff, hard, and abrasion resistant (hence their use for bearings and cutting tools); they retain their strength to high temperatures; and they resist corrosion well<sup>[1]</sup>.

### C. Polymers

Polymers include the familiar plastic and rubber materials. Many of them are organic compounds that are chemically based on carbon, hydrogen, and other nonmetallic elements (viz. O, N, and Si). Furthermore, they have very large molecular structures, often chain-like in nature that have a backbone of carbon atoms. They are not as stiff nor as strong as these other material types. Typically, these materials have low densities and based on those, many times their stiffnesses and strengths on a per mass basis are comparable to the metals and ceramics. In addition, many of the polymers are extremely ductile and pliable (i.e., plastic), which means they are easily formed into complex shapes.

<b>International Association Of Certified Practicing Engineers</b>	<b>ENGINEERING MATERIALS AND THEIR STRENGTH</b>	<b>Page 12 of 151</b>
	<b>CPE LEVEL I TRAINING MODULE</b>	
	<b>Jan 2015</b>	

#### D. Composite

A composite is composed of two (or more) individual materials, which come from the categories such as metals, ceramics, and polymers. The design goal of a composite is to achieve a combination of properties that is not displayed by any single material, and also to incorporate the best characteristics of each of the component materials<sup>[7]</sup>. Fiber-reinforced composites are, of course, the most familiar. Most of those at present available to the engineer have a polymer matrix reinforced by fibers of glass, carbon or Kevlar (an aramid).

### III. Mechanical Behaviors and Properties of Materials

The fundamental concepts in mechanics of materials are considered by description as follow.

#### A. Stress and Strain Behaviours

In the design process, one of an important problem is to ensure that the strength of the mechanical element to be designed always exceeds the stress due to any load exerted on it. Stress is the force per unit area and is usually expressed in pounds per square inch. If the stress tends to stretch or lengthen the material, it is called tensile stress; if to compress or shorten the material, a compressive stress; and if to shear the material, which is caused by forces perpendicular to the area on which they act, it is called shearing stress. Tensile and compressive stresses always act at right-angles to (normal to) the area being considered; shearing stresses are always in the plane of the area (at right-angles to compressive or tensile stresses)<sup>[14]</sup>.

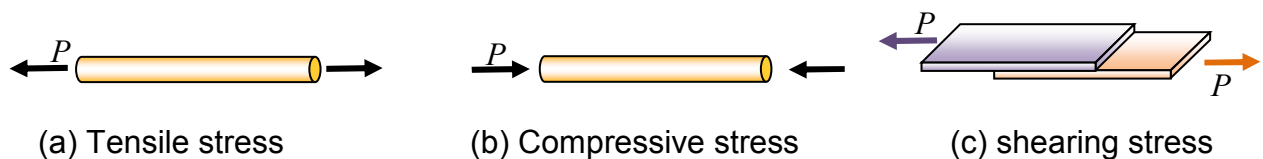

Figure 1 : stress types

Strain is known as deformation produced by stress, strain is the ratio of the change in length caused by the applied force, to the original length. Typically, material is done tensile test to know stress – strain curve by static loading of a standard specimen or specifying the strain rate as the independent variable, in which case the loading rate is continuously

International Association Of Certified Practicing Engineers	ENGINEERING MATERIALS AND THEIR STRENGTH	Page 13 of 151
	CPE LEVEL I TRAINING MODULE	Rev: 02
		Jan 2015

adjusted to maintain the required strain rate. Stress-strain curve is a characteristic of the particular material being tested and conveys important information about the mechanical properties and type of behavior<sup>[20]</sup>.

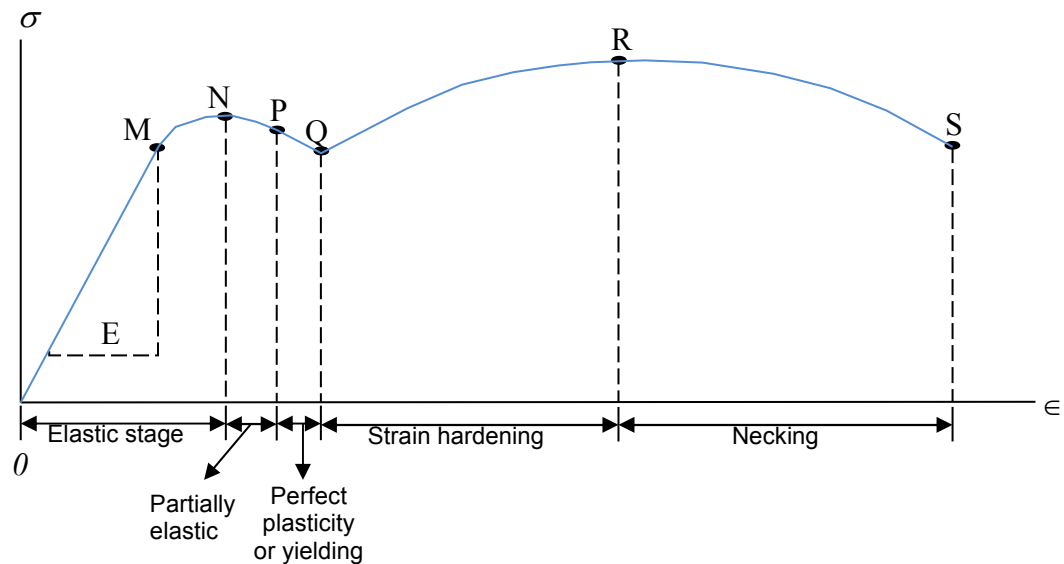

Figure 2 : stress-strain curve

The figure explains that the points at curve are :

a. Proportional Limit

The proportional limit is the highest stress at which stress is linearly proportional to strain. This is also the point at which the curve first begins to deviate from a straight line. The point lies at M and the slope in this stage is called Young's Modulus E.

b. Elastic Limit

Elastic limit is the maximum stress to which a test specimen may be subjected and still return to its original length upon release of the load. At point N elastic limit is reached. For most materials and applications this can be considered the practical limit to the maximum stress a component can withstand and still function as designed.

<b>International Association Of Certified Practicing Engineers</b>	<b>ENGINEERING MATERIALS AND THEIR STRENGTH</b>	Page 14 of 151
		Rev: 02
		Jan 2015
<b>CPE LEVEL I TRAINING MODULE</b>		

c. Yield

Yield point is a point on the stress-strain curve at which there is a sudden increase in strain without a corresponding increase in stress. Commonly, there are two points P and Q, the upper and lower yield points. Not all materials have an obvious yield point, especially for brittle materials.

The yield strength is the minimum stress which produces permanent plastic deformation. The yield strength also is indicative of the ease of forming or shaping metals by mechanical stress. The yield strength is usually defined at a specific amount of plastic strain, or offset, which may vary by material and or specification. The offset is the amount that the stress-strain curve deviates from the linear elastic line. The most common offset for structural metals is 0.2%<sup>[6]</sup>.

d. Ultimate Tensile Strength

The ultimate tensile strength (UTS) is the maximum load sustained by the specimen divided by the original specimen cross-sectional area. This point lies at R. When this point is reached, the deformation or extension continues even with lesser load and ultimately fracture occurs at point S.

Combined Stresses refer to the situation in which stresses are present on each of the faces of a cubic element of the material. For a given cube orientation the applied stresses may include shear stresses over the cube faces as well as stresses normal to them.

## B. Fatigue

Generally, fatigue is understood as the gradual deterioration of a material which is subjected to repeated loads. In fatigue testing, a specimen is subjected to periodically varying constant-amplitude stresses by means of mechanical or magnetic devices. The most common loading is alternate tension and compression of equal numerical values obtained by rotating a smooth cylindrical specimen while under a bending load. A series of fatigue tests are made on a number of specimens of the material at different stress levels.

## C. Creep

In metals, creep is plastic deformation caused by slip occurring along crystallographic directions in the individual crystals, together with some flow of the grain-boundary material. After complete release of load, a small fraction of this plastic deformation is recovered with time. Most of the flow is nonrecoverable for metals. The most common are the long-time

<b>International Association Of Certified Practicing Engineers</b>	<b>ENGINEERING MATERIALS AND THEIR STRENGTH</b>	<b>Page 15 of 151</b>
		<b>Rev: 02</b>
		<b>Jan 2015</b>
<b>CPE LEVEL I TRAINING MODULE</b>		

creep test under the stress-relaxation test and the constant-strain-rate test. The long time creep test is conducted by applying a dead weight to one end of a lever system, the other end being attached to the specimen surrounded by a furnace and held at constant temperature.

#### **D. Hardness**

Hardness has been variously described as resistance to local penetration, to scratching, to machining, to wear or abrasion, and to yielding. The multiplicity of definitions, and corresponding multiplicity of hardness-measuring instruments, together with the lack of a fundamental definition, indicates that hardness may not be a fundamental property of a material but rather a composite one including yield strength, work-hardening, true tensile strength, modulus of elasticity, and others.

<b>International Association Of Certified Practicing Engineers</b>	<b>ENGINEERING MATERIALS AND THEIR STRENGTH</b>  <b>CPE LEVEL I TRAINING MODULE</b>	Page 16 of 151
		Rev: 02
		Jan 2015

## DEFINITIONS

**Amorphous** - Not having a crystal structure; noncrystalline.

**Bending stress** - A physical quantity of combination amount of distance from 'centre – pooint' material and bending moment that divided by second moment area of section.

**Bolts**– A conjunction inbetween two separate material for a non-permanent fastening.

**Combined Stresses**– An event when stresses are present on each of the faces of a cubic element of material.

**Creep** – Plastic deformation caused by slip occuring along crystallographic directions in individual crystals.

**Crystalline polymer**- A polymer with ordered structure that has been allowed to disentangle and form crystals such as HDPE. Thus, isotactic polypropylene, cellulose, and stretched rubber are crystalline polymers.

**Ductility** - The ability of a material to be bent, formed, or stretched without rupturing. Measured by

elongation or reduction of area in a tensile test or by other means.

**Elastic limit** - The maximum stress to which a test specimen may be subjected and still return to its original length upon release of the load.

**Endurance limit** - The maximum stress below which a material can presumably endure an infinite number of stress cycles.

**Eutectic** - upon cooling, a liquid phase transforms isothermally and reversibly into two intimately mixed solid phases; the lowest melting composition in a material system.

**Factor of Safety** – The ratio of the actual strength to the required strength

**Fatigue** – Gradual deterioration of material which is subjected to repeated loads.

**Failure Event**– An event that established as a result of crack propagation without plastic deformation at a stress well below the elastic limit.

<b>International Association Of Certified Practicing Engineers</b>	<b>ENGINEERING MATERIALS AND THEIR STRENGTH</b>	<b>Page 17 of 151</b>
		<b>Rev: 02</b>
		<b>Jan 2015</b>
<b>CPE LEVEL I TRAINING MODULE</b>		

**Glass transition temperature ( $T_g$ )-** A characteristic temperature at which glassy amorphous polymers become flexible or rubber-like because of the onset of segmental motion

**Hardness**—Resistance of materials to any force load from its outside surface such as local penetration, scratching, machining, abrasion or yielding.

**Melting point ( $T_m$ )-** The first-order transition when the solid and liquid phases are in equilibrium.

**Modulus** - The ratio of stress to strain, as of strength to elongation, which is a measure of stiffness of a polymer.

**Proportional limit** - The highest stress at which stress is linearly proportional to strain.

**Strain**—How much an extension of any materials from its original length.

**Stress** —An amount of force load to a certain area of material.

**Spherulites-** Aggregates of polymer crystallites.

**Stress Concentration Factor ( $K$ )**—A highest value of stress at discontinuity divided to an amount of stress at its minimum cross-section area.

**Torsion** —The twisting of an object due to an applied torque.

**Ultimate Tensile Strength (UTS)**—The maximum load sustained by the specimen divided by the original specimen cross-sectional area.

**Welds**—An activity to join two separate material by an addition of metals or thermoplastics by causing coalescence.

**Yield point** - A point on the stress-strain curve at which there is a sudden increase in strain without a corresponding increase in stress.

<b>International Association Of Certified Practicing Engineers</b>	<b>ENGINEERING MATERIALS AND THEIR STRENGTH</b>	Page 18 of 151
		Rev: 02
		Jan 2015
<b>CPE LEVEL I TRAINING MODULE</b>		

## NOMENCLATURE

A	: Area of cross section, in <sup>2</sup> (m <sup>2</sup> )
a	: Thickness of the fork, in (m)
B	: Bulk compliance, psi <sup>-1</sup> (Pascal / N/m <sup>2</sup> ) <sup>-1</sup>
b	: The thickness of the eye, in (m)
C	: Distance across corners, in (mm)
c	: Radius, in (m)
D	: Diameter, in (m)
D	: Outside or major diameter of thread, in (mm)
D	: Tensile compliance, psi <sup>-1</sup> (Pascal / N/m <sup>2</sup> ) <sup>-1</sup>
E	: Young's Modulus, psi (Pascal / N/m <sup>2</sup> )
F	: Force, lbf (N)
f	: Frequency, Hz (s <sup>-1</sup> )
G	: Shear Modulus, psi (Pascal / N/m <sup>2</sup> )
h	: Height fallen mass, in (m)
I	: Second moment of area of section lbf.in <sup>2</sup> (kg.m <sup>2</sup> )
J	: Polar moment of inertia, in <sup>4</sup> (m <sup>4</sup> )
K	: Bulk Modulus, psi (Pascal / N/m <sup>2</sup> )
L	: Length, in (mm)
M	: Bending moment, lbf.in (Nm)
m	: Weibull's modulus constant
N	: Shaft speed, rpm
P	: Load, lb (N)
P	: Power, hp (watts)
p	: Mean perimeter, in (m)
S	: Elastic section modulus, I/c, in <sup>3</sup> (m <sup>3</sup> )
T	: Torque, lb.in or lb.ft (N.m)
t	: Thickness, in (m)
V	: Volume fraction, dimensionless
v	: Velocity, in/s (m/s)
v	: Poisson's ratio, dimensionless
x <sub>s</sub>	: Steady extension, in (m)

<b>International Association Of Certified Practicing Engineers</b>	<b>ENGINEERING MATERIALS AND THEIR STRENGTH</b>	<b>Page 19 of 151</b>
		<b>Rev: 02</b>
		<b>Jan 2015</b>
<b>CPE LEVEL I TRAINING MODULE</b>		

### Greek Letter

$\delta$	: Total elongation, in (m)
$\epsilon$	: strain, in/in (m/m)
$\tau$	: shear stress, psi (Pascal / N/m <sup>2</sup> )
$\tau_m$	: Maximum shear stress, psi (Pascal / N/m <sup>2</sup> )
$\gamma$	: shear strain, in/in (m/m)
$\rho$	: radius of curvature of the path, ft (m)
$\sigma$	: Stress, psi (Pascal / N/m <sup>2</sup> )
$\sigma$	: bending stress, psi (Pascal / N/m <sup>2</sup> )
$\sigma_m$	: Maximum tensile stress, psi (Pascal / N/m <sup>2</sup> )
$\sigma_s$	: Steady stress, psi (Pascal / N/m <sup>2</sup> )
$\phi$	: angle twist, rad

<b>International Association Of Certified Practicing Engineers</b>	<b>ENGINEERING MATERIALS AND THEIR STRENGTH</b>	<b>Page 20 of 151</b>
		<b>Rev: 02</b>
		<b>Jan 2015</b>
<b>CPE LEVEL I TRAINING MODULE</b>		

## **THEORY**

### **I. Engineering Materials**

Solid materials have been conveniently grouped into three basic classifications: metals, ceramics, and polymers. In addition, there are the composites, combinations of two or more of the above three basic material classes. These material types and representative characteristics are explained as follows.

#### **A. Metals**

In these materials, there are commonly two classes, they include ferrous metals and non-ferrous metals which are described as follow.

##### **a. Ferrous Metals**

These are metals and alloys containing a high proportion of the element iron. They are the strongest materials available and are used for applications where high strength is required at relatively low cost and where weight is not of primary importance. As an example of ferrous metals such as : bridge building, the structure of large buildings, railway lines, locomotives and rolling stock and the bodies and highly stressed engine parts of road vehicles. The ferrous metals themselves can also be classified into two classifications which are described as follow.

##### **i. Cast Iron**

Cast Iron is an alloy of iron containing enough carbon to have a low melting temperature and which can be cast to close to final shape<sup>[2]</sup>. It includes iron – carbon alloys with carbon content ca. 2.8 – 4%. The carbon is for the most part not chemically bonded to the iron, but is present in elemental form. Types of cast iron involve Grey Iron, Spherical Graphite (SG) Cast Iron, Cast Iron with Vermicular Graphite, Alloyed Cast Iron, White Cast Iron and Roll Casting.

##### **- Gray Iron**

Cast iron with flake graphite, also known as gray iron, is an iron-based material in which the carbon is nearly all in the form of microscopic graphite flakes with a ferritic – pearlitic structure. Table 1 represents the properties of some grey irons.

<b>International Association Of Certified Practicing Engineers</b>	<b>ENGINEERING MATERIALS AND THEIR STRENGTH</b>	Page 21 of 151
		Rev: 02
	<b>CPE LEVEL I TRAINING MODULE</b>	Jan 2015

Table 1: properties of grey irons

Grade	Tensile Strength (N/mm <sup>2</sup> )	Compressive Strength (N/mm <sup>2</sup> )	Transverse Strength (N/mm <sup>2</sup> )	Hardness BHN*	Modulus of elasticity (GN/m <sup>2</sup> )
10	160	620	290 – 370	160 – 180	76 – 104
17	260	770	450 – 490	190 – 250	110 – 130
24	370	1240	620 – 700	240 – 300	124 – 145

\*BHN = Brinell Hardness Number

#### - Spheroidal Graphite (SG) Cast Iron

In spheroidal graphite, also known as ductile iron or nodular iron is the free graphite in the ferritic – pearlitic matrix which almost completely in spheroidal form. Nodular (ductile) cast iron is also produced by adding alloys of magnesium or cerium to molten iron<sup>[2]</sup>. A large consumer of SG iron is the gas and water pipe industry, which produces centrifugally cast pressure pipes and special pieces (in example elbows, Y-pieces, T-pieces, etc). Table 2 shows the properties respected to some SG irons.

Table 2 : properties of SG iron

Grade	Tensile Strength (N/mm <sup>2</sup> )	0.5% permanent set stress (N/mm <sup>2</sup> )	Hardness BHN*	Modulus elongation (%)
SNG 24/17	370	230	140 – 170	17
SNG 37/2	570	390	210 – 310	2
SNG 47/2	730	460	280 – 450	2

#### - Cast Iron with Vermicular Graphite

The graphite that separates put is mainly in vermicular form by this type of cast iron. The connection between the cast iron and vermiculate-mineral usually a magnesium – aluminum silicate which only conceptual. The basic structure of cast iron with vermicular graphite can be ferritic, pearlitic, or a mixed structure. The mechanical properties of the material lie varies between the grey iron and SG iron range.

<b>International Association Of Certified Practicing Engineers</b>	<b>ENGINEERING MATERIALS AND THEIR STRENGTH</b>	<b>Page 22 of 151</b>
		<b>Rev: 02</b>
		<b>Jan 2015</b>
<b>CPE LEVEL I TRAINING MODULE</b>		

- **Alloyed Cast Iron**

The properties of cast iron can be modified within wide limits by adding elements like nickel, chromium, manganese, copper, and silicon which could change the metallic structure. This type of cast iron is often called an alloyed cast iron. Alloyed cast iron has a wide range of applications, from the chemical industry, in furnaces, the automobile industry, the cryogenic industry, and also for the electrical industry such as for non-magnetic materials or materials with high electrical resistivity.

- **White Cast Iron and Roll Casting**

White Cast and Roll Casting is a special grade of cast iron, the carbon in the structure is not graphite, but iron carbide ( $\text{Fe}_3\text{C}$ ). White cast iron is extremely resistant to abrasion by frictional and grinding effects. These benefits could be used for rolling operations, in grinding parts, and also in mixing processes.

- **Malleable Cast Iron**

These are formed after heat treating white cast iron. Heat treatments involve heating the material up to 800-900 °C, and keep it for long hours, before cooling it to room temperature. High temperature incubation causes cementite to decompose and form ferrite and graphite. Thus these materials are stronger with an appreciable amount of ductility. Typical applications include: railroad, connecting rods, marine and other heavy-duty services.

ii. **Steel**

a) **Carbon Steels**

On heat treatment and hot rolling, steels are oxidized and decarburized. At first, only iron is oxidized and carbon is enriched in the metal below scale. By continuing this process, vacancies condense at the interface to form voids in which  $\text{CO}_2$  and CO are formed in equilibrium with FeO. This gas diffuses outward through cracks and pores of the scale, which leads to carbon loss. A steady state is achieved in which the carbon supply to the interface is controlled by diffusion in the metal. After long-term oxidation, the steel is always decarburized.

Special carbon steels are of higher purity than high-grade steels, and contain fewer non-metallic inclusions. They are mostly intended for quenching and tempering or surface hardening, and show a consistent response to these treatments. The

<b>International Association Of Certified Practicing Engineers</b>	<b>ENGINEERING MATERIALS AND THEIR STRENGTH</b>	Page 23 of 151
		Rev: 02
		Jan 2015
<b>CPE LEVEL I TRAINING MODULE</b>		

properties of carbon steels are shown in Table 3. The table provides an information such as types, its composition, and the mechanical properties of each types.

Table 3 : properties of carbon steels

Type	Composition			Mechanical Properties		
	C	Si	Mn	Tensile Strength (N/mm <sup>2</sup> )	Elongation (%)	Hardness BHN*
070 M20	0.2	-	0.7	400	21	150
070 M26	0.26	-	0.7	430	20	165
080 M30	0.3	-	0.8	460	20	165
080 M36	0.36	-	0.8	490	18	180
080 M40	0.4	-	0.8	510	16	180
080 M46	0.46	-	0.8	540	14	205
080 M50	0.5	-	0.8	570	14	205
216 M28	0.28	0.25	1.3	540	10	180
080 M15	0.15	0.5	0.8	460	16	-
060 M96	0.99 – 1.0	0.1 – 0.7	0.5 – 0.7	1300	-	500

Plain carbon steels have been used for temperatures up to 400°C with low mechanical stresses. A fine-grained structural steels with improved high-temperature properties have been developed. Their carbon contains has been reduced to the value of less than 0.15% to improve their toughness and to limit hardening in heat-affected zones. They usually contain  $\leq 2\%$  manganese and small additions of aluminum, vanadium, niobium, and nitrogen in various to give increased strength by grain refinement. In fact, plain carbon steels are divided into three main group : low-carbon steel, medium-carbon steel, and high-carbon steel which are described as follow.

#### - **Low-Carbon Steel**

Low-carbon steel by weight contains 0.05% to 0.30% carbon and is often referred to as mild steel. It is unresponsive to heat treatments intended to form martensite; strengthening is accomplished by cold work. Microstructures consist of ferrite and pearlite constituents. Low-carbon steel is used for forge work, rivets, chains, structural shapes and machine parts that do not need great strength.

<b>International Association Of Certified Practicing Engineers</b>	<b>ENGINEERING MATERIALS AND THEIR STRENGTH</b>	Page 24 of 151
		Rev: 02
		Jan 2015
<b>CPE LEVEL I TRAINING MODULE</b>		

- **Medium-Carbon Steel**

Medium-carbon steel has more carbon and is stronger than low-carbon steel. It contains 0.30% to 0.60% carbon. Medium-carbon steel is used for bolts, shafts, car axles, rails and other parts or tools that require strong metal. Medium-carbon steels are frequently hardened and tempered by heat treatment.

- **High-Carbon Steel**

High-carbon steel is the hardest, strongest, and yet least ductile of the carbon steels. High-carbon steel is also known as carbon tool steel, contains between 0.60% and 1.5% carbon. The best grades of this steel are made in electric furnaces. High-carbon steel is called tool steel because it is used to make such tools as drills, taps, dies, reamers, files, cold chisels, crowbars, and hammers. It is hard to bend, weld, and cut<sup>[28]</sup>.

**b) Alloy Steels**

Alloy steels which are multicomponent systems containing Fe and C, that C can be aperted not only from  $M_3C$ , but also the cabides compound such as  $M_7C_3$ ,  $M_{23}C_6$ ,  $M_2C$ ,  $MC$ , and intermetallic phases, where M represents a metal subtituent. In an alloy steel the content of an individual element reaches or exceeds the limiting values that is shown in Table 4.

Table 4 : concentration limits of elements for alloy steel

Element	Limiting Concentration (%)
Aluminum (Al)	0.10
Boron (B)	0.0008
Bismuth (Bi)	0.10
Cobalt (Co)	0.10
Chromium (Cr)	0.30
Copper (Cu)*	0.40
Lanthanides (La) [assessed separately]	0.05
Manganese (Mn)	1.65***
Molybdenum (Mo)*	0.08
Niobium (Nb)**	0.06
Nickel (Ni)*	0.30
Lead (Pb)	0.40

<b>International Association Of Certified Practicing Engineers</b>	<b>ENGINEERING MATERIALS AND THEIR STRENGTH</b>	Page 25 of 151
		Rev: 02
		Jan 2015
<b>CPE LEVEL I TRAINING MODULE</b>		

Continued from table 4

Element	Limiting Concentration (%)
Selenium (Se)	0.10
Silicon (Si)	0.50
Tellurium (Te)	0.10
Titanium (Ti)**	0.05
Vanadium (V)**	0.10
Tungsten (W)	0.10
Zirconium (Zr)**	0.05
Others (except C, N, O, S), each	0.05

\*If two, three, or four of these elements are present in concentration less than the maximum permitted, their total concentration should not exceed 70% of the sum of the maxima.

\*\*The same rule applies to these elements

\*\*\*If the manganese content is quoted as a minimum, this value applies.

Furthermore, some standards divide steel into several main quality groups including for a High-grade alloy steel. High-grade alloy steels are actually have similar applications to high-grade unalloyed steels, but contain level of alloying elements (to give special properties) that place them among the alloy steels (Table 4). They are in general unsuitable for quenching and tempering or surface hardening. Meanwhile, Table 5 shows the typical properties of alloy steels.

Field weldability is of special significance factor when efficient welding processes are used e.g., vertical down welding using cellulose-coated electrodes, and mechanized welding with protective gas, assessment of fabricability being the main consideration. For this kind of purposes, a special carbon equivalent (CE) could be formulated for low-alloy steel as follows :

$$CE, \% = C, \% + \frac{Si, \%}{25} + \frac{Mn, \% + Cu, \%}{20} + \frac{Cr, \%}{10} + \frac{Ni, \%}{40} + \frac{Mo, \%}{15} + \frac{V, \%}{10} \quad \text{Eq (1)}$$

Noted that the equation above is suitable for assessing the hardening tendency of steel. To measure susceptibility to cold cracking, the implant test usually added.

<b>International Association Of Certified Practicing Engineers</b>	<b>ENGINEERING MATERIALS AND THEIR STRENGTH</b>	Page 26 of 151
		Rev: 02
	<b>CPE LEVEL I TRAINING MODULE</b>	Jan 2015

Table 5 : typical properties of alloy steels

Content	Specification	Tensile Strength (N/mm <sup>2</sup> )	Fatigue limit (N/mm <sup>2</sup> )	Weld ability	Corrosion resistance	Machine ability	Form ability
Low	709M40	1240	540	PH/FTHR	PR	F/HTR	F
	817M40	1550	700	PH/FTHR	PR	P/HTR	F
	835M30	1550	700	PH/FTHR	PR	P/HTR	F
	897M39	1310	620	PH/FTHR	PR	P/HTR	F
	AISI H11	(1780) 2010 (A2630)	850 (A1880)	PH/FTHR	PR	P/HTR	F
Medium	HP9/4/45	1390	-	FTHR	PR	F	F
	410S21	1850	340	P/FTHR	F	F	F
	Vascojet MA	1160	960	PH/FTHR	PR	F	F
High	316S12	620	260	G	G	F	G
	317S16	650	260	G	G	F	G
	AISI 301	740	280	F	F	F	G
	REX 627	1470	540	FTHR	F	F	F

\*A = Ausformed, MA = Martempered, CR = Cold rolled, P = Poor, F = Fair, G = Good, PH = Preheat required, PR = Protection required, HT = at high temperature, HTR = when heat treated, FHTR = final heat treatment required.

In steel production, the properties of various grades of steel are achieved by adding alloying elements. Alloy steel can also be returned to the material recycle, if its sorted according to the chemical composition. The alloying elements are retained when the scrap is melted, and new alloy steels can be produced from this metal.

### c) Stainless Steels

Stainless steel is a steel that contains special chemical properties. As in general, stainless steels have high resistance to chemically aggressive materials. They are usually used under normal environmental conditions (air or water) and in corrosive chemical solutions (acids and alkalies). These kind of steels have Chromium contain at least 12% and alloying additions of Ni, Mo, Cu, Si, Ti, Nb, or other elements.

Areas of application of these steels are range from domestic equipment, motor vehicles, and architecture, to chemical equipment, energy generation, marine technology, and environmental protection. The grades of these steels could be including Ferritic steels, Martensitic steels, Austenitic steels, or Ferritic – Austenitic steels.

<b>International Association Of Certified Practicing Engineers</b>	<b>ENGINEERING MATERIALS AND THEIR STRENGTH</b>	Page 27 of 151
		Rev: 02
		Jan 2015
<b>CPE LEVEL I TRAINING MODULE</b>		

- **Ferritic Steels**

This group starts with 11% Cr steels with low corrosion resistance, e.g., for vehicle construction and for containers. The superferrites (with 30% Cr and 5% Mo) steels are produced with extremely low carbon and nitrogen content, and could be stabilized further by addition of Nb. Normal ferritic chromium steels have their ductile – brittle transition temperature near room temperature. On the other hand, the superferrites temperature transition is shifted to lower temperature and the upper shelf energy measured on the notched-bar impact specimen to be strongly improved. This kind of steel is used for seawater desalination plants and flue gas desulfurization plants.

- **Martensitic Steels**

Only moderate corrosion resistance can be achieved with martensitic chromium steels due to the consumer requests. The chromium content approximately in range 13 – 17% but it can be improved by adding ca. 1.5% Mo. Higher strength and hardness can be established from normal martensitic chromium steels with carbon content 0.20 – 1%. In the quenched and tempered condition, steel grades containing 0.20% C are used for steam turbine blades and other machine component. The higher-carbon steels are used in the hardened condition for cutting equipment, roller bearings, and components with good wear resistance properties. The toughness can be increased by stress relieving at 200 - 350°C.

- **Austenitic Steels**

The austenitic Cr – Ni steels constitute is the highest proportion of stainless steels that have been produced. As well as the basic grade containing 18% Cr and 9% Ni. A large number of steels with reduced carbon content and additions of N, Mo, Cu, Si, Ti, and Nb have also been developed. The Cr – Ni steels are used for kitchen equipment, interior decorations, and components of exterior architecture that are not subjected to severe corrosion. Austenitic Cr – Ni – Mo steels are preferred for greater resistance to pitting and receive corrosion by aggressive outside atmospheres, for domestic pipework, and in automobile construction. Both these basic types of austenitic steels are also widely used in the chemical industry.

- **Ferritic – Austenitic Steels**

The importance of the ferritic – austenitic steels has increased considerably because of their spectrum of useful properties. Their composition range including > 20% Cr, 5 – 8% Ni, and ≤ 3% Mo, leads to mixed structure of austenitic and ferrite. This

<b>International Association Of Certified Practicing Engineers</b>	<b>ENGINEERING MATERIALS AND THEIR STRENGTH</b>	Page 28 of 151
		Rev: 02
		Jan 2015
<b>CPE LEVEL I TRAINING MODULE</b>		

enables 0.2% offset yield strength  $> 450\text{N/mm}^2$  to be achieved at room temperature. The ferritic – austenitic steels have a lower thermal expansion and a better thermal conductivity than the austenitic steels. These type of steels also have a grade that often used in seawater desalination plants, sour gas pipelines, and especially where their good resistance to stress corrosion cracking and corrosion fatigue is important, e.g., in chemical and petrochemical industries, especially if the components concerned are in motion.

#### b. Non – Ferrous Metals

Copper and its derivative such as copper alloys, and Aluminum constituents including aluminum alloys are involved to the Non – Ferrous Metals type. Electrolytically refined copper (99.95% pure) is used for components requiring high conductivity. Less pure copper compounds typically used for chemical plant, domestic plumbing, etc. Copper is also available in the form of wire, sheet, strip, plate, round bar and tube. Copper is used in many alloys including brasses, bronzes, aluminum bronze, cupronickel, nickel-silver and beryllium-copper. Table 6 provides the mechanical properties of some copper alloys.

Table 6 : mechanical properties of copper alloys

Type	Mechanical Properties			
	0.1% proof stress (N/mm <sup>2</sup> )	Tensile Strength (N/mm <sup>2</sup> )	Elongation (%)	Vickers Hardness
Muntz Metal	110	350	40	75
Free-cutting Brass	140	440	30	100
Cartridge Brass	75	270	70	65
Standard Brass	90	320	16	85
Phosphor Bronze	120	280	15	90

Pure Aluminum is available in grades from 99% to 99.99% purity. It is soft and ductile but work hardens. Pure aluminium is difficult to cast. An aluminium alloys could classified as follows :

- (a) Wrought alloys (including heat treatable and non-heat treatable).
- (b) Casting alloys (heat-treatable and non-heat treatable).

<b>International Association Of Certified Practicing Engineers</b>	<b>ENGINEERING MATERIALS AND THEIR STRENGTH</b>	Page 29 of 151
		Rev: 02
		Jan 2015
<b>CPE LEVEL I TRAINING MODULE</b>		

The mechanical properties of several aluminium casting alloys are shown in table 7.

Table 7 : mechanical properties of an aluminium casting alloys

Type	Condition	0.1% proof stress (N/mm <sup>2</sup> )	Tensile Strength (N/mm <sup>2</sup> )	Elongation (%)	Hardness BHN	Machinability
Cast Alloys	Sand cast	60	160	5	50	Difficult
	Chill cast	70	190	7	55	Difficult
	Die cast	120	280	2	55	-
Heat Treatable	Chill cast	-	300	9	-	Good
	Fully heat treated	-	300	9	-	Good

### c. Corrosion of Metals

As in general, corrosion topic had been important due to the material changes, especially in metallic compounds. Some literatures simply are described as an electrochemical oxidation of metals in reaction with an oxidant like Oxygen (O<sub>2</sub>). The 'Corrosion-reaction' are mainly electrochemical, although they can also involve chemical or metallophysical processes. However, a corrosive reaction with the environment can be brought about by erosion of protective coatings (erosive corrosion).

The types of material changes bring about by corrosion are manifold. A distinction is made between uniform and nonuniform surface corrosion, pitting, selective corrosion, and cracking (types of corrosion). Of these, the local corrosion processes are particularly critical. Since corrosion reactions generally occur on the metal surface, they are termed interfacial processes and can be represented by a phase.

The corrosion process takes place at the metal – medium phase boundary and is therefore a heterogeneous reaction in which the structure and condition of the reaction surface play a significant role. Essential points as example, are whether the surface is uncoated, whether it is covered with an adhesive compact or loose, porous coating, or whether its properties have been changed by machining and processing.

<b>International Association Of Certified Practicing Engineers</b>	<b>ENGINEERING MATERIALS AND THEIR STRENGTH</b>	Page 30 of 151
		Rev: 02
		Jan 2015
<b>CPE LEVEL I TRAINING MODULE</b>		

### **i. Corrosion under Mechanical Stress**

Stress corrosion cracking is one of the most unpleasant forms of corrosion because it usually occurs unexpectedly and can very quickly lead to cracking in equipment such as reactors, vessels, and piping and to fractures in components of all kinds. Depending on the alloy system and corrosive medium, the characteristics are divided into several categories including the inter- or transgranular brittle cracking, branching out to varying degrees into the material and eventually causing fracture of the remaining cross section.

An anodic stress corrosion cracking could be caused by a combination of mechanical tensile stress and local electrolyte dissolution processes when certain conditions are met. Protective layers are a prerequisite for stress corrosion cracking to occur on the surface of a component under the influence of an electrolyte. The most common interpretation of the mechanism of cracking is based on a "periodic electrochemical-mechanical process".

#### **- Unalloyed and Low – Alloy Steels**

In unalloyed and low-alloy steels, the corrosive media (alkali, nitrates) produce passive protective layers which have a certain instability at high-angle grain boundaries and are thus decomposed under sufficient stress, initiating local corrosion. In practice, the considerable influence of the stress level can also be seen by the fact that weld seams are preferentially attacked by stress corrosion cracking on account of shrinkage stresses and the stresses caused by structural changes due to the effect of heat input during welding. In alloyed air-hardened steels (e.g., 13 CrMo 44), thorough tempering at 750°C is needed after welding to eliminate the hardness structure.

#### **- Stainless Steels**

Chloride-containing corrosive media can give rise to transgranular stress corrosion cracking austenitic stainless steels. Alkali-metal hydroxide solutions could also cause stress corrosion cracking in austenitic stainless steels, albeit only at elevated temperature, often above the boiling point of the corrosive medium. Therefore, transgranular stress corrosion cracking could occur in the presence of halides under two conditions : (1). Below the limit stress through shifting of the corrosion potential towards the pitting potential by oxidants. (2). Above the limit stress through the occurrence of local yield processes with the formation of corroded spots with high current density.

<b>International Association Of Certified Practicing Engineers</b>	<b>ENGINEERING MATERIALS AND THEIR STRENGTH</b>	Page 31 of 151
		Rev: 02
		Jan 2015
<b>CPE LEVEL I TRAINING MODULE</b>		

- **Nonferrous Metals**

In the presence of specific corrosive media, nonferrous alloys are also prone to stress corrosion cracking. Some aluminum alloys that contain Zn and Mg in example, are sensitive to chloride solutions and seawater. On the other hand, for copper alloys, especially brass, are attacked by moist ammonia could cause cracking. In aluminum alloys, cracking is intergranular, and the formation of the cracks is related to the chemical activity of the grain boundaries.

- **Special Case of Stress Corrosion Cracking**

An uncommon category of stress corrosion, which is of importance in practice, is transgranular cracking of copper-containing stainless austenitic Cr-Ni-Mo steels in sulfuric acid. Cracking depends on the concentration and temperature of the acid and the level of mechanical stress. Transgranular stress corrosion cracking induced not only in austenitic stainless steels but also in nickel alloys by aqueous alkaline solutions.

ii. **Oxidation of Technical Alloys**

- **Steels**

The scaling of steels in air has so far been investigated more thoroughly than any other media. Since the corrosion conditions in technical gases can differ appreciably from those in air, extrapolation of parameters determined in air to the service behavior of steels is only possible to a limited extent. The time function of oxidation is formulated as :

$$\Delta m^n = k \cdot t \quad \text{Eq (2)}$$

Where,

- $\Delta m$  : the mass loss or increase (kg)
- t : time (s)
- k : the scale constant
- n : dimensionless exponent

Values of  $n \geq 2$  indicate resistance capacity, while if the values  $< 2$  represent imply lack of resistance. Unalloyed steels can be used in air up to 550°C and low-alloy steels could be up to 600°C. Figure 3 shows an example of the applicability of high-

<b>International Association Of Certified Practicing Engineers</b>	<b>ENGINEERING MATERIALS AND THEIR STRENGTH</b>	<b>Page 32 of 151</b>
		<b>Rev: 02</b>
	<b>CPE LEVEL I TRAINING MODULE</b>	<b>Jan 2015</b>

alloy steels which had been determined by the alloy contents with an additional special metals such as Cr.

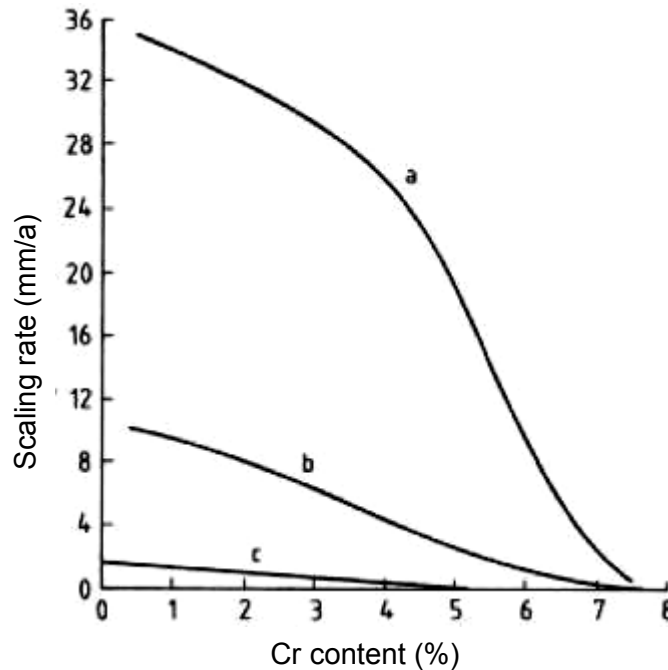

Figure 3 : influence of Cr content (containing 0.15% C and 0.7 – 0.9% Si).

Where,

- a : at temperature 800°C
- b : at temperature 700°C
- c : at temperature 600°C

The same time laws basically could be applied to scaling the carbon dioxide as to scaling in air, but with carbon dioxide, graphite deposits in the scale can occur in unalloyed and low-alloy steels, and carborization in austenitic steels. The penetration carbon into an alloy can lead to the following processes, which alter properties and reduce scaling resistance : (1). Lowering the melting point (by 350°C in Ni-Cr alloys), (2) Carbide formation with chromium depletion, (3) Formation of a brittle, intermetallic  $\sigma$ -phase.

<b>International Association Of Certified Practicing Engineers</b>	<b>ENGINEERING MATERIALS AND THEIR STRENGTH</b>	Page 33 of 151
		Rev: 02
		Jan 2015

Graphite contents in the scale lead to a loosening of the oxide film and accelerate the oxidation rate. The addition of carbon monoxide to carbon dioxide reduces the scaling rate. The effect is particularly marked in the low-temperature-region in unalloyed and low-alloyed steels. On the other hand, water content at the addition of high carbon dioxide pressure could cause a premature breakdown like a formation of noncovering oxide films. Hence, the scaling rate is influenced by the breakdown event.

- **Nickel Alloys**

Nickel alloys with more than 15% Cr represents a good oxidation properties, which are due largely to the presence of an outer  $\text{Cr}_2\text{O}_3$  layer. In general, higher application temperatures than in air are possible. Nickel has high affinity for sulfur and combines with it to form the eutectic Ni –  $\text{Ni}_3\text{S}_2$  which melts at  $645^\circ\text{C}$ . However, even at ca,  $100^\circ\text{C}$  below melting temperature, annealing in sulfur gases leads to penetration of sulfur into nickel, especially along the grain boundaries.

- **Cobalt Alloys**

Oxidation of Co – Cr alloys at many ways is similar to the Nickel types. The rate of cobalt oxidation is faster than for nickel. Under equivalent conditions Co is even richer in cation vacancies than NiO. Small Cr contents (below 20%) will increase the rate of reaction. More chromium is usually needed to stabilize a protective film since the diffusion coefficient of chromium in cobalt is lower than for Cr in Nickel. However, since the adhesion strength of the film on Cr – Co alloys is poorer than on Ni – Cr type, the practical oxidation resistance is also lowered.

**iii. General Corrosion Protection and Inhibitors**

The best possible protection usually achieved by through the choices of suitable material coating. Given extensive corrosion attack, this can mean compulsory use of expensive materials that may not always prove satisfactory in mechanical terms. Solution of this problem is provided by a composite system such as the underlying function of such a system is provided by a chad base material with good mechanical properties while the corrosion resistance is imparted by a coating material with relatively low thickness.

Inhibitors are substance that remove and minimize the aggressiveness of a corrosive medium and are either already contained in the corrosive medium or are specifically added to it. A distinction is made between electrochemical, chemical and physical inhibitors.

<b>International Association Of Certified Practicing Engineers</b>	<b>ENGINEERING MATERIALS AND THEIR STRENGTH</b>	<b>Page 34 of 151</b>
		<b>Rev: 02</b>
		<b>Jan 2015</b>
<b>CPE LEVEL I TRAINING MODULE</b>		

Industrial application of inhibitors involves acidic, neutral, and alkaline solutions as well as the gas phase. Physical and electrochemical inhibitors could be used for acids, whereas all of the types are employed in neutral and alkaline solutions. Gas and vapor phase inhibitors have gained importance, especially in atmospheric corrosion protection in storage and transportation.

For chemical industry, inhibitors in open and closed water circulation systems and in oil refinery are highly significant. In oil refineries, the cracking that may occur in heat-treatable steels through the action of weakly acidic solutions containing  $H_2S$  and  $H_2O$  can be removed by the addition of ammonia saturated with oxygen ( $O_2$ ). The  $H_2S$  is oxidized to polysulfide, which forms a good protective coating on the steel. Corrosion inhibitors for mineral oils include alkyl imidazoles, amines, aminopyridines, quaternary ammonium salts, alkyl sulfonates, borate esters, hydroxy amines, naphthenic acids, phosphate esters and stearates.

Oxygen and carbon dioxide corrosion could cause serious economic loss in water circulation systems in which water is heated, evaporated or condensed. Oxygen-binding additives offer good protection (hydrazine, Levoxin, sodium sulfite) and are used extensively in boiler feed water preparation. Carbon dioxide corrosion can be controlled by neutralizing and film-forming amines and by vapor phase inhibitors. In practice derivatives of phosphoric acid, organophosphates, and chelates have proved successful as inhibitors in open cooling circulation systems.

#### **d. Mechanical Processing of Metals**

Metals are fabricated by different means to achieve metals and alloys of desired characteristics. There been many kinds of fabrication techniques, and for a particular metal use of these depend on properties of metal, product shape-size-properties, cost, etc. Metal fabrication techniques are mainly four kinds<sup>[1]</sup>:

- Casting  
Casting is used to give a shape by pouring in liquid metal into a mold that holds the required shape, and letting harden the metal without external pressure;
- Forming  
Forming is used to give shape in solid state by applying pressure;
- Machining  
Machining is used in which material is removed in order to give it the required shape;

<b>International Association Of Certified Practicing Engineers</b>	<b>ENGINEERING MATERIALS AND THEIR STRENGTH</b>	<b>Page 35 of 151</b>
		<b>Rev: 02</b>
		<b>Jan 2015</b>
<b>CPE LEVEL I TRAINING MODULE</b>		

- Joining

Joining is used where different parts are joined by various means. One of the most important miscellaneous techniques is powder metallurgy that means metal powders or mixture of metal powers at desired relative amounts are compacted into the desired shape, followed by sintering in controlled atmosphere to produce a denser product.

Apart from mechanical processing, metals are very often subjected to thermal processing for various reasons, like: to refine grain structure/size, to minimize residual stresses, to impart phase changes, to develop special phases over external surfaces, etc. Metals and alloys develop requisite properties by thermal processing either through grain refinement of phase changes. Metals are subjected to heat treatment (thermal processing) for one or more of the following purposes: improvement in ductility; relieving internal stresses; grain size refinement; increase of strength; improvement in machinability, toughness; etc.

Thermal processes may be broadly classified into two categories based on cooling rates from elevated temperatures – annealing and quenching & tempering. Annealing involved cooling the material from elevated temperatures slowly, while quenching means very fast cooling of the material using cooling medium like water/oil bath. Quenching is done to retain the phases of elevated temperatures at room temperature<sup>[17]</sup>.

<b>International Association Of Certified Practicing Engineers</b>	<b>ENGINEERING MATERIALS AND THEIR STRENGTH</b>	<b>Page 36 of 151</b>
		<b>Rev: 02</b>
	<b>CPE LEVEL I TRAINING MODULE</b>	<b>Jan 2015</b>

Following figure is illustration of manufacturing process for iron and steel<sup>[24]</sup>.

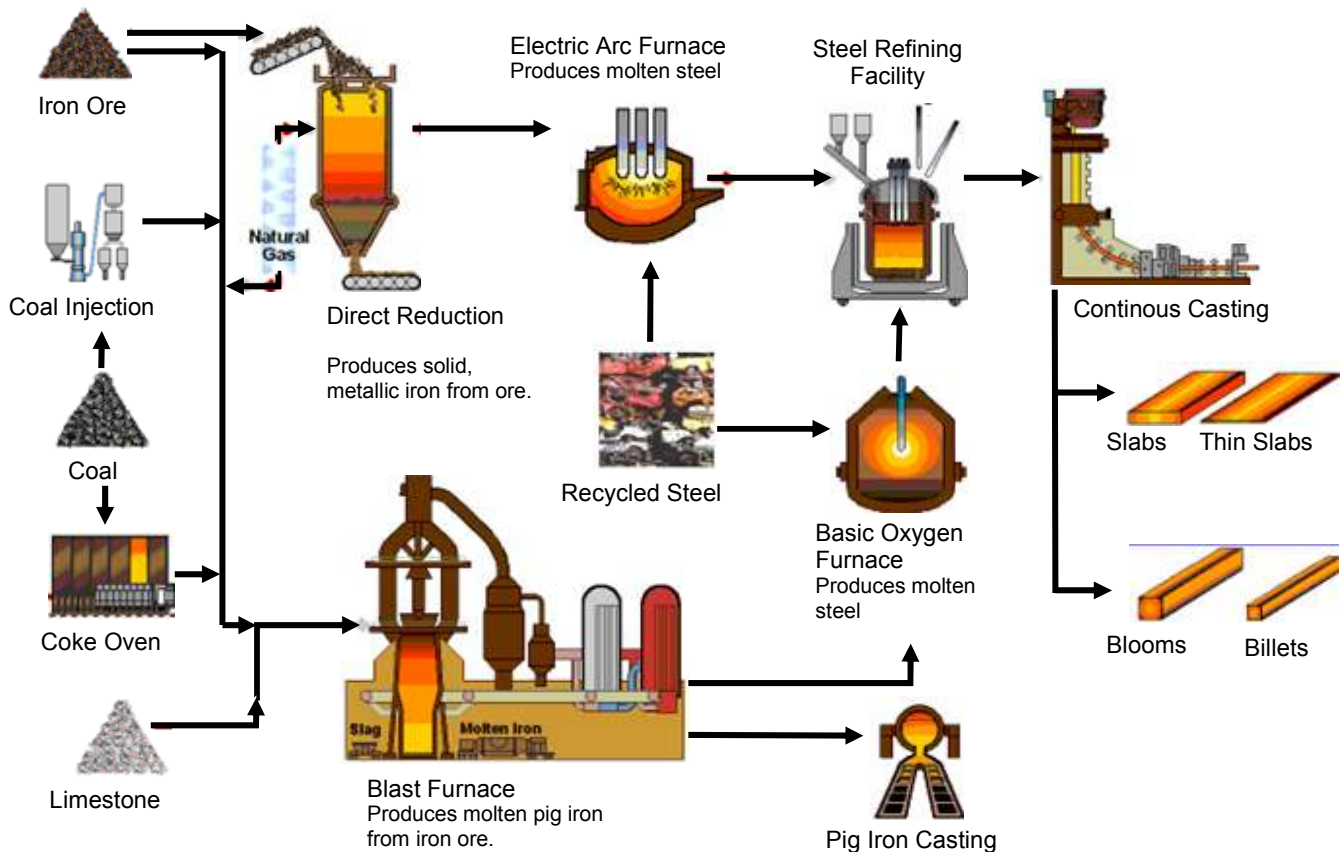

Figure 4 : manufacturing process for iron and steel

## B. Polymers

Polymers are high molecular weight compounds or macromolecules composed of many repeating molecular units called monomer, connected by covalent bonds or chemical bonds. The reaction involving combination of two or more monomer units to form a long chain polymer is termed as polymerization. The source of virgin raw materials, or feedstock, is generally petroleum or natural gas<sup>[2]</sup>. The example is ethylene units become 'Polyethylene' ( $R'(CH_2CH_2)_nR''$ ).

Plastics are commercially used materials that are based in polymers or prepolymers. 'Plastics' refers to the ancient greek letter '*plastain*' that have meaning 'to form' or 'to

<b>International Association Of Certified Practicing Engineers</b>	<b>ENGINEERING MATERIALS AND THEIR STRENGTH</b>	Page 37 of 151
		Rev: 02
		Jan 2015
<b>CPE LEVEL I TRAINING MODULE</b>		

shape'. Plastic types are characterized by one to three sets of leading criteria, selected from :

- Chemical bonds and its structure data like content of Vinyl acetate (VAC) of Acrylonitrile units (AN).
- Bulk Density (BD).
- Molar mass data such as intrinsic viscosity (IV) or Fikenscher's K value (FK).
- Mechanical properties such as modulus of elasticity (E), Tensile stress at 100% strain (TS), Shore Hardness (SH), or Impact Strength Notched (ISN).
- Thermal data, in example : Vicat Temperature (VT) or Torsional Shiftness Temperature (TSN).
- Rheological data such as melt flow rate (MFR).

The standard designation of a thermoplastic material consists of a description block, a standard number block and a series of data blocks. Table 8 represents the criteria of the most used chemical properties characterization.

Table 8 : example of plastic specification

<b>Chemical Compounds</b>	<b>Selection of Criteria</b>
Polyethylene	D, MFR
Polypropylene	I, MFR
Polystyrene and Acrylonitrile – Styrene copolymers	VT, MFR
Styrene – Butadiene, Acrylonitrile – Butadiene – Styrene (ABS), and Acrylonitrile – Styrene – Acrylic acid copolymers	VT, MFR, ISN
Ethylene – Vinyl acetate copolymers	VAC, MFR
Poly(vinyl chloride)	IV, FK, BD
Poly(vinyl chloride), unplasticized	VT, E, ISN
Poly(vinyl chloride), plasticized	TS, SH, TST
Polyamides	IV, E
Polycarbonates	IV, MFR, E
Poly(methyl methacrylate)	IV, VT
Poly(ethylene terephthalate)	IV

<b>International Association Of Certified Practicing Engineers</b>	<b>ENGINEERING MATERIALS AND THEIR STRENGTH</b>	Page 38 of 151
		Rev: 02
		Jan 2015
<b>CPE LEVEL I TRAINING MODULE</b>		

The rapid growth of plastics production (Table 9) is a result of three key factors : (1) growth of world population, (2) average increase in standard of living, and (3) replacement of older materials by plastics. The world population grew from  $2.532 \times 10^9$  at the begin of year 1950, to  $5.32 \times 10^9$  in 1980, while the world plastics production (estimated equal to consumption) climbed from 0.6 kg per capita (1950) to 18.8 kg per capita (1990).

Table 9 : numbers on plastic

Region / Country	Production in $10^6$ t/a				
	1950	1960	1970	1980	1990
European Community	0.3	2.3	11.5	19.7	30
United States	1.1	2.8	9.1	16.1	30
Japan	0.04	0.7	5.3	7.5	13
Eastern Europe	0.1	0.5	4.0	6.9	13
Other	0.07	0.3	1.1	8.8	14
<b>Total</b>	<b>1.6</b>	<b>6.7</b>	<b>31.0</b>	<b>59.0</b>	<b>100</b>
<b>World Population, <math>\times 10^{-6}</math></b>	<b>2532</b>	<b>3062</b>	<b>3730</b>	<b>4498</b>	<b>5320</b>
<b>Per capita consumption in kg</b>	<b>0.6</b>	<b>2.2</b>	<b>8.3</b>	<b>13.1</b>	<b>18.8</b>

Since construction and packaging are major applications for lumber, steel, and aluminium, it can be expected that plastics became more important replacements for these materials. Packaging and building – construction are indeed the most important applications of plastics.

Table 10: U.S Plastics sales and Applications (1988)

Polymer	Domestic Sales	Domestic Applications <sup>a</sup>							
		A	B	E	F	H	P	T	Y
PE – HD	3743	9	251	53	5	143	1692	19	77
PE – LD	4479		127	168	4	191	1092	20	74
PP	3316	67	18	21	30	92	470	170	18
PS	2329	77	127	186	55	115	108		108
SAN	62	10		2		10	8		
ABS	562	91	69	53	2		2	95	17
Other styrenics	553								
PPO alloys	82	20	2	1					
PVC	3779	64	2301	232	41	29	199	101	15

<b>International Association Of Certified Practicing Engineers</b>	<b>ENGINEERING MATERIALS AND THEIR STRENGTH</b>	Page 39 of 151
		Rev: 02
		Jan 2015
<b>CPE LEVEL I TRAINING MODULE</b>		

Continued from Table 10

Polymer	Domestic Sales	Domestic Applications <sup>a</sup>							
		A	B	E	F	H	P	T	Y
Other vinyls <sup>b</sup>	435		2				53		
PMMA	316	4	110					25	
POM	58	5	7	2				12	
PA	253	8		36			25	69	
PC	195	16	52	25				28	
PETP, PBT	911	3	3	20			450	20	
Fluoropolymers	13								
Cellulosics	41	1	2	2			3		1
Thermoplastic Elastomers	225								
UP <sup>c</sup>	623	30	132	17	9			64	
EP	213	4	19	25			15	45	
PF <sup>d</sup>	1376	15	411	45	77	18	6	10	
UF, MF <sup>d</sup>	688		121	14	10	6	3		
PUR <sup>e</sup>	1319	73	309		257				331
Alkyds	145								
Other <sup>f</sup>	500	16		21	3	29	86	52	41

<sup>a</sup> A=Appliances, B=Building/Construction, E=Electrical, F=Furniture, H=Household goods, P=Packaging, T=Transportation, Y=Toys.

<sup>b</sup> Poly(vinyl acetate), Poly(vinyl butyral), Ethylene – vinyl alcohol copolymers, etc.

<sup>c</sup> without glass fibers.

<sup>d</sup> Resin in plywood assumed as 20%.

<sup>e</sup> Raw materials.

<sup>f</sup> Coumarones, high-performance resins, etc.

<b>International Association Of Certified Practicing Engineers</b>	<b>ENGINEERING MATERIALS AND THEIR STRENGTH</b>	<b>Page 40 of 151</b>
		<b>Rev: 02</b>
		<b>Jan 2015</b>
<b>CPE LEVEL I TRAINING MODULE</b>		

### **a. Classification of Polymers**

Polymers can be classified into five classes which consider several basis such as source or origin, structure, type of monomer, polymerization, and molecular force. They can be explained as follow.

#### **a) Based on the source**

On the basis of source or origin, the polymers are classified into three types which are described as follow :

##### 1. Natural polymers

Natural polymers are polymers which are found in nature mostly in plants and animal sources. The examples are Proteins, Cellulose, Starch, and Natural rubber.

##### 2. Semi-synthetic polymers

These are mostly derived from naturally occurring polymers by carrying out chemical modifications. The examples are Cellulose diacetate and Cellulose nitrate.

##### 3. Synthetic polymers

The polymers which are prepared in the laboratory are referred to as synthetic polymers or man-made polymers. Some examples of the synthetic polymers are polyethylene, polystyrene, PTFE synthetic rubber, nylon, PVC, bakelite, teflon, orion, etc<sup>[26]</sup>.

#### **b) Based on the structure**

The physical characteristics of a polymer depend not only on its molecular weight and shape but also on differences in the structure of the molecular chains. Several types of molecular structure are possible and can be controlled over various structural possibilities.

##### 1. Linear polymers

Linear polymers are those in which the repeat units are joined together end to end in single chains. Some of the common polymers that form with linear structures are polyethylene, poly(vinyl chloride), polystyrene, and nylon.

<b>International Association Of Certified Practicing Engineers</b>	<b>ENGINEERING MATERIALS AND THEIR STRENGTH</b>	<b>Page 41 of 151</b>
	<b>CPE LEVEL I TRAINING MODULE</b>	
	<b>Rev: 02</b>	
		<b>Jan 2015</b>

These long chains are flexible and may be thought of as a mass of spaghetti, as represented schematically in figure 5<sup>[7]</sup>.

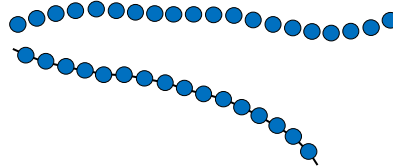

Figure 5 : linear polymers

## 2. Branched polymers

Branched polymers are polymers that may be synthesized in which side-branch chains are connected to the main ones. For example, high density polyethylene (HDPE) is primarily a linear polymer, while low density polyethylene (LDPE) contains short chain branches. Branched polymers are also distinguished into several types :

- *Star Polymer*, this polymer possesses one branching point from which three or more subchains radiate.
- *Dendrime*, is the star polymer in which the subchains are themselves starlike branched. It is often called cascade polymer.
- *Comb Polymer*, it has a long side chains, which its chemical structure usually differs from the main chain. It also refers the graft polymer for which branches have been introduced by its subsequent.

The types of those branched polymers can be illustrated in figure 6.

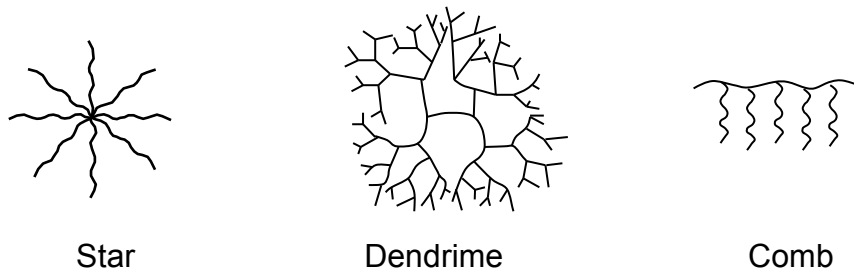

Figure 6 : types of branched polymers

<b>International Association Of Certified Practicing Engineers</b>	<b>ENGINEERING MATERIALS AND THEIR STRENGTH</b>	<b>Page 42 of 151</b>
		<b>Rev: 02</b>
	<b>CPE LEVEL I TRAINING MODULE</b>	<b>Jan 2015</b>

### 3. Crosslinked polymers

These polymers are characterized with adjacent linear chains that are joined one to another at various positions by covalent bonds, as represented in Figure 7. Cross linking is done during synthesis or by a non-reversible chemical reaction. Often, this crosslinking is accomplished by additive atoms or molecules that are covalently bonded to the chains. The applications of this polymers are bakelite and melamine.

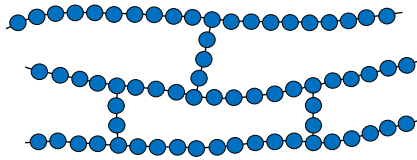

Figure 7 : crosslinked polymers

### 4. Network polymers

These polymers are formed when multifunctional monomers forming three or more active covalent bonds, make three-dimensional networks. A polymer that is highly cross linked may also be classified as a network polymer. The epoxies, polyurethanes and phenol-formaldehyde belong to this group of polymers. Network polymers can be illustrated in figure 8.

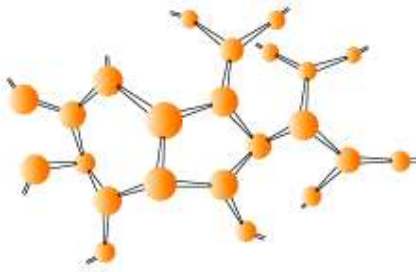

Figure 8 : network polymers

## c) Based on types of monomers

### 1. Homopolymers

Homopolymer is the resulting polymer that all the repeating units along a chain are of the same type of monomers. The term homopolymer thus refers to origin of the monomers in a polymer and not to the actual constitutional units. As an example, the polymerization of a

<b>International Association Of Certified Practicing Engineers</b>	<b>ENGINEERING MATERIALS AND THEIR STRENGTH</b>	<b>Page 43 of 151</b>
	<b>CPE LEVEL I TRAINING MODULE</b>	<b>Rev: 02</b>
		<b>Jan 2015</b>

monomer  $\text{CH}_2=\text{CHR}$  leads to constitutional units  $-\text{CH}_2\text{CHR}-$ , where R represents an atom or side group other than hydrogen (e.g., Cl,  $\text{CH}_3$ ). The position also could have configurations such 'head to head' or 'tail to tail' arrangements as shown in Figure 9.

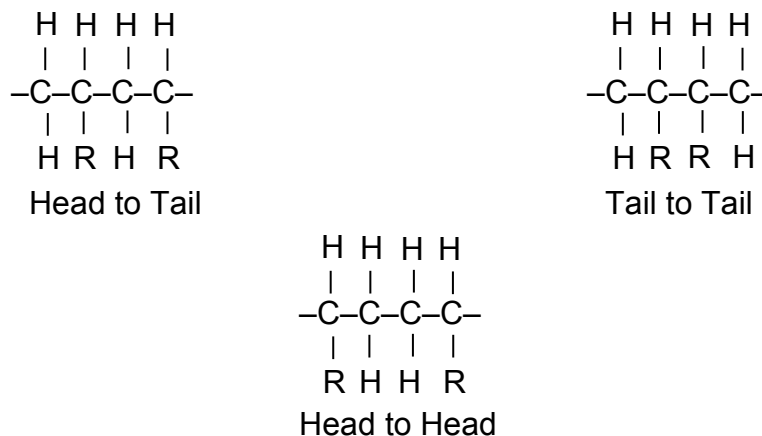

Figure 9 : Homopolymer Structures

## 2. Copolymers

Copolymers are chains that may be composed of two or more different repeat units. They are also often called as bipolymers, terpolymers, quaterpolymers, etc, according to the number of monomer types. As an example the copolymerization of ethylene and propylene would lead to the bipolymer poly(ethylene- co-propylene). The succession of monomeric units in copolymer chains is known as their sequence. Types of copolymers can be shown in table 11.

Table 11 : types of copolymers from monomers

Name	Structure	Shorthand name
Copolymer without specified sequence	~(a/b)~	Poly(A-co-B)
Statistical copolymer	~a-b-b-b-a-a-b-a-a-a-a-b~	Poly(A-stat-B)
Random copolymer (Bernoulli statistics of sequence)	~a-b-b-a-a-a-b-a-a-b~	Poly(A-ran-B)
Alternating copolymer	~a-b-a-b-a-b-a-b-a-b~	Poly(A-alt-B)
Periodic copolymer	~-a-b-c-a-b-c-a-b-c~	Poly(A-per-B-per-C)
Diblock copolymer	~a.....a-b.....b~	Poly(A)-block-poly(B)

<b>International Association Of Certified Practicing Engineers</b>	<b>ENGINEERING MATERIALS AND THEIR STRENGTH</b>	<b>Page 44 of 151</b>
		<b>Rev: 02</b>
	<b>CPE LEVEL I TRAINING MODULE</b>	<b>Jan 2015</b>

Continued from Table 11

Name	Structure	Shorthand name
Triblock copolymer	~a.....a-b.....b-c.....c~	Poly(A)-block-poly(B)- block-poly(C)
Graft copolymer	<pre>       b               b         -a-a-a-a-a-a-a-a-a-a-a-                                   b                                   b           </pre>	Poly(A)-graft-poly(B)

The sequence of monomeric knits in statistical copolymers is determined by the statistics of copolymerization. On the other hand random copolymers are special cases of statistical copolymers, the sequence follows Bernoulli statistics.

#### d) Based on polymerization

Classification based on polymerization can be divided into two types. There are addition polymers and condensation polymers which described as follow.

##### 1. Addition polymers

Addition polymers are formed by the repeated addition of monomer molecules possessing double or triple bonds. As example, poly(ethylene) and poly(propylene).

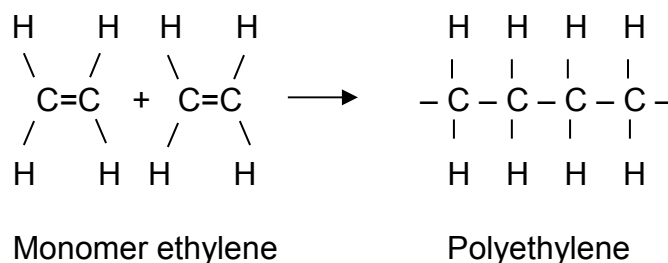

Figure 10 : addition polymers

<b>International Association Of Certified Practicing Engineers</b>	<b>ENGINEERING MATERIALS AND THEIR STRENGTH</b>	<b>Page 45 of 151</b>
	<b>CPE LEVEL I TRAINING MODULE</b>	<b>Rev: 02</b>
		<b>Jan 2015</b>

## 2. Condensation polymers

Condensation polymers are formed by repeated condensation reaction between two different bi-functional or tri-functional monomeric units. Example of this type is illustrated as follow.

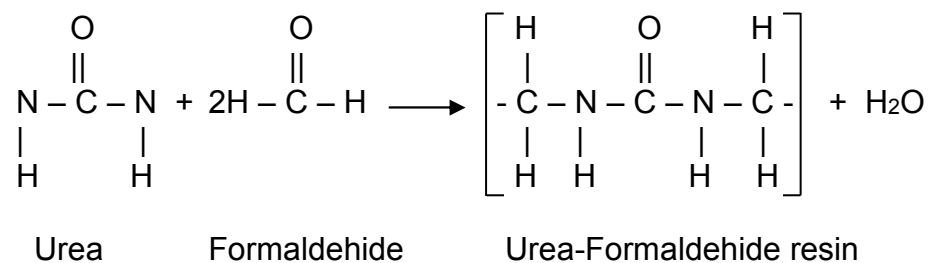

Figure 11 : condensation polymers

### e) Based on molecular force

The response of a polymer to mechanical forces at elevated temperatures is related to its dominant molecular structure. There are thermoplastic and thermoset which are described as follow.

#### a. Thermoplastic

Thermoplastics is the solid material that yielded by a simple cooling of physical process (melting) and soften while being heated. The shaping of a thermoplastic is a reversible process, the same material could be melted and processed again. Most linear polymers and those having some branched structures with flexible chains are thermoplastic.

#### b. Thermoset

Thermoset solidifies irreversibly when heated. Thermosets cannot be reshaped by heating. Thermosets usually are three-dimensional networked polymers in which there is a high degree of cross-linking between polymer chains. The cross-linking restricts the motion of the chains and leads to a rigid material<sup>[29]</sup>.

<b>International Association Of Certified Practicing Engineers</b>	<b>ENGINEERING MATERIALS AND THEIR STRENGTH</b>	<b>Page 46 of 151</b>
		<b>Rev: 02</b>
		<b>Jan 2015</b>
<b>CPE LEVEL I TRAINING MODULE</b>		

### **b. Plastic Manufacture**

Polymerization reaction do not deliver polymers that can be used directly as raw material for plastics product. The polymer should go to further process such as filtration, melting, beading, powdering, pelleting and being granulated must be degassed, and also all the particualtes must be dried or conditioned to environmental. Beads from suspension polymerization are washed and polymer solutions concentrated.

Batchwise polymerizations often lead to slightly different products, which are mixed to guarantee customers polymer grads according to specifications. Granules and pellets are sometimes similarly blended by macrohomogenization.

Compounding is the process that mixed between the polymers and the additives compound. This process could be performed either by adding single additives one at a time, by using additive systems, or by employing master batches. Additive systems are carefully adjusted mixtures of additives that are formulated to avoid mutually synergistic or antagnoistic effetcts. Master batches are concentrates of additives in polymers, they facilitate the dosage of small amounts of additives.

The properties of compounds depend very much on the compounding process. Only heterogeneous compounds result when poly(vinyl chloride) is mixed with additives in regular mixers, these compounds could not be processed directly to the end-use products. High performance of mixers would delivered free-flowing poowders, these 'dry-blends' could be extruded and injection molded. Compounding is also often carried out by specialized compounders.

### **c. Mechanical Properties of Polymers**

#### **i. Mechanical Behaviour**

Most polymers consist of a combination of crystalline and amorphous regions. This combination of crystalline and amorphous regions is important for the formation of materials that have both good strength (contributed to largely by the crystalline portions) and some flexibility or "softness" (derived from the amorphous portions). The kind, amount, and distribution of polymer chain order/disorder (amorphous/crystalline) is driven by the processing (including pre- and post-) conditions and thus it is possible to vary the polymer properties through a knowledge of and ability to control the molecular-level structures.

A characteristic temperature at which glassy amorphous polymers become flexible or rubber-like because of the onset of segmental motion, is called the glass transition

temperature. To be useful as plastics and elastomers, the polymers must be at a temperature below and above the glass transition temperature, respectively<sup>[8]</sup>. It can be described by figure 12 for amorphous polystyrene (thermoplastic)<sup>[7]</sup>.

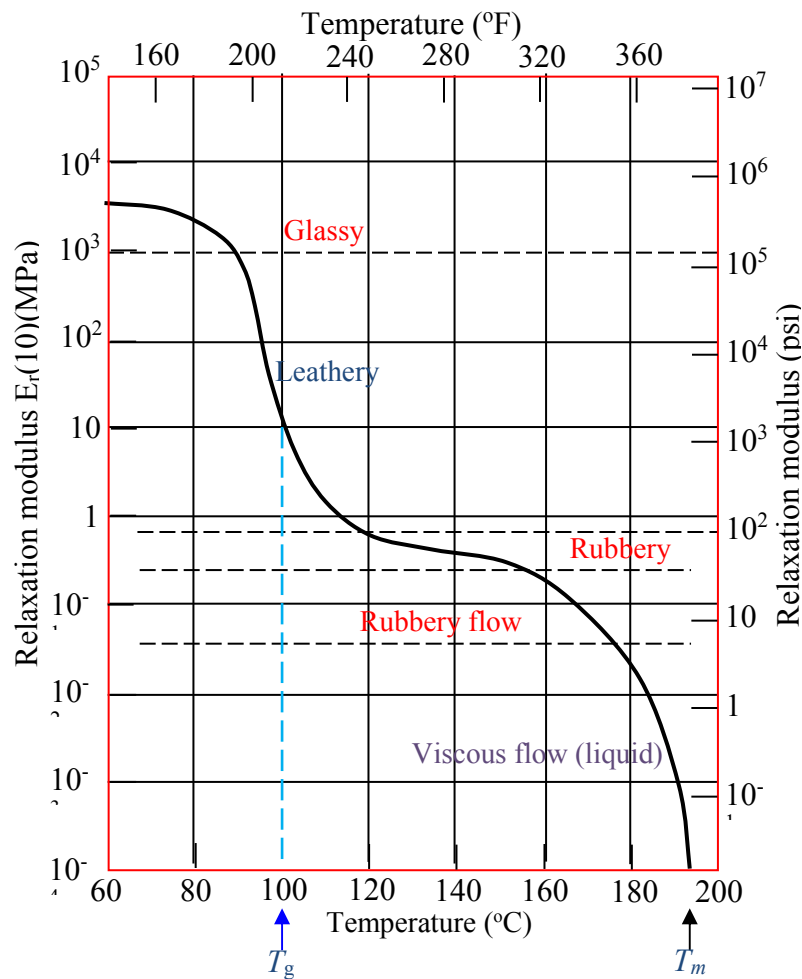

Figure 12 : Logarithm of the elastic modulus versus temperature

An orderly, the mechanical properties of crystalline polymers requires their classification into several categories, as indicated in Table 12. It is in the range of intermediate degree of crystallinity that the properties, unique to polymers, of most importance for mechanical and engineering applications are found<sup>[4]</sup>.

<b>International Association Of Certified Practicing Engineers</b>	<b>ENGINEERING MATERIALS AND THEIR STRENGTH</b>	Page 48 of 151
		Rev: 02
		Jan 2015
<b>CPE LEVEL I TRAINING MODULE</b>		

Table 12 : classification of crystalline polymers

Predominant properties in temperature range	Degree of crystallinity		
	Low (5 – 10%)	Intermediate (20 – 60%)	High (70 – 90%)
Above T <sub>g</sub>	Rubbery	Leathery, tough	Stiff, hard (brittle)
Below T <sub>g</sub>	Glassy, brittle	Hornlike, tough	Stiff, hard, brittle

The mechanical properties of polymers are specified with many of the same parameters that are used for metals. For many polymeric materials, the simple stress–strain test is employed for the characterization of some of these mechanical parameters<sup>[7]</sup>.

There are three major classes of polymers exist that differ in their behavior under mechanical loading over a wide temperature range : thermoplastics, elastomers, and thermosets. Their differences in behavior result essentially from differences in physical as well as chemical structure.

### 1. Thermoplastics

This class includes uncrosslinked amorphous or partially crystalline plastics. At low temperature they are energy elastic, but above a certain temperature they exhibit viscous flow. Softening takes place in the glass transition range for amorphous thermoplastics and in the crystallite melting range for partially crystalline thermoplastics. Between the elastic and viscous-flow ranges, there may be temperature range in which the material behaves in a rubber like (entropy-elastic) manner. Figure 13 and Figure 14 are the shear modulus versus temperature and the stress versus strain graphic for thermoplastics.

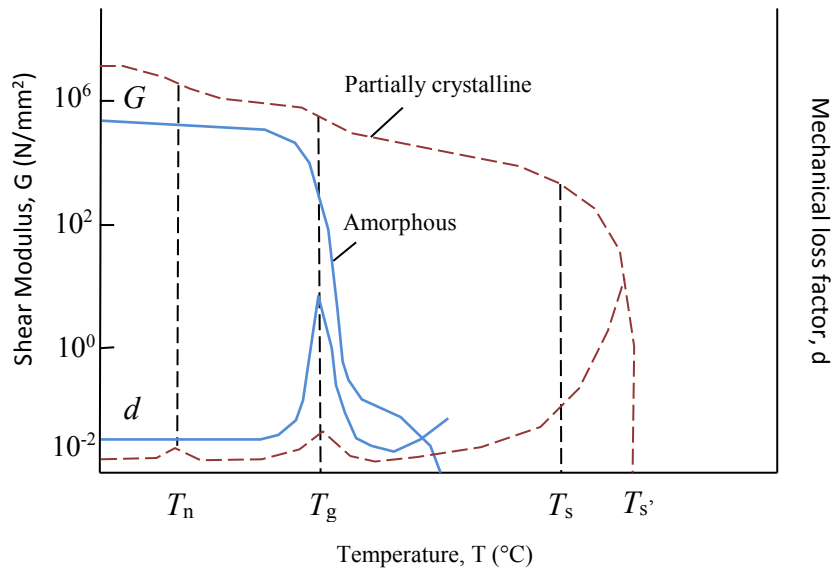

Figure 13 : Shear Modulus vs Temperature

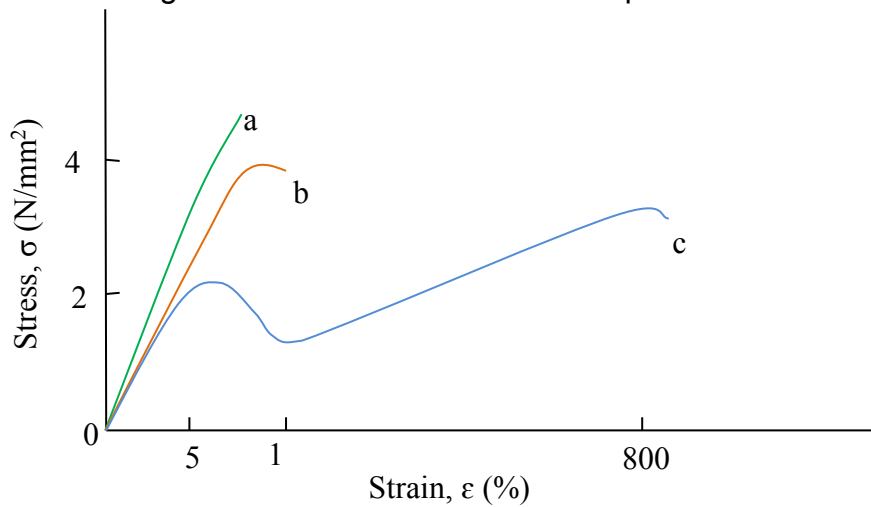

Figure 14 : Stress vs Strain

Where,

a) Amorphous material at moderate temperature.

b) Amorphous and partially crystalline material at moderate temperature and strain rate.

c) Partially crystalline material at moderate temperature and strain rate

<b>International Association Of Certified Practicing Engineers</b>	<b>ENGINEERING MATERIALS AND THEIR STRENGTH</b>	<b>Page 50 of 151</b>
		<b>Rev: 02</b>
	<b>CPE LEVEL I TRAINING MODULE</b>	<b>Jan 2015</b>

In un-crosslinked substances such as thermoplastics or in only partially cross-linked substances, entropy-elastic and viscous properties are superimposed.

## 2. Thermosets

Thermosets are closely cross-linked polymers that exhibit energy elastic or energy/entropy elastic behavior at low temperature. At or above 60°C, the polymers show entropy-elastic behavior with very limited deformability. Figure 15 and Figure 16 are quoted as typical curves of shear modulus and loss factor versus temperature and of stress versus strain for thermosets type. These graphs are taken from an example of phenolic resins differing in degree of cross-linking. They also show how, as cross-linking increases, the glass transition temperature increases and the main transition step becomes smaller, while the curve becomes flatter and the damping maximum becomes lower and broader. The steps disappear altogether upon curing and no main softening occurs in the closely-cross-linked network.

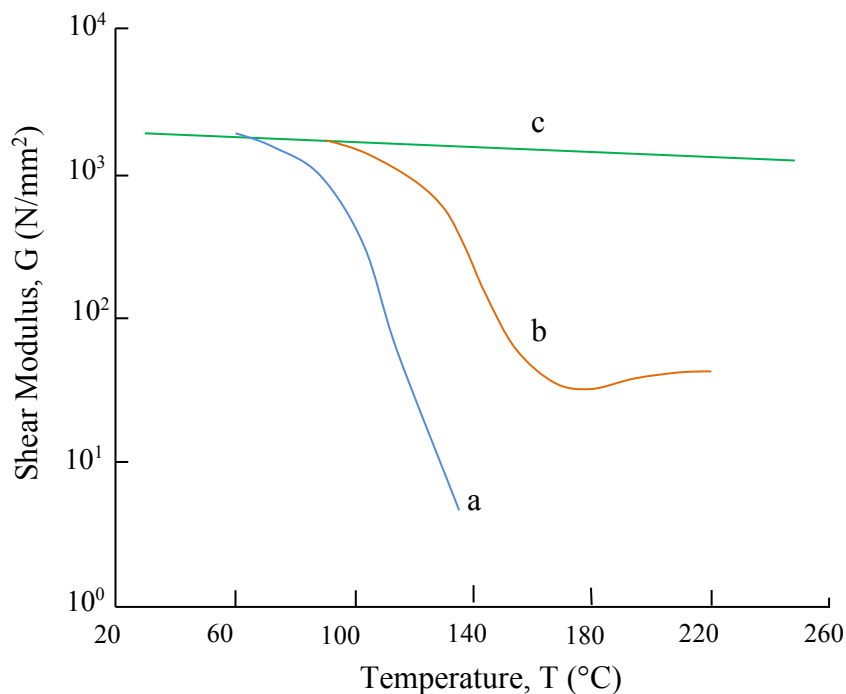

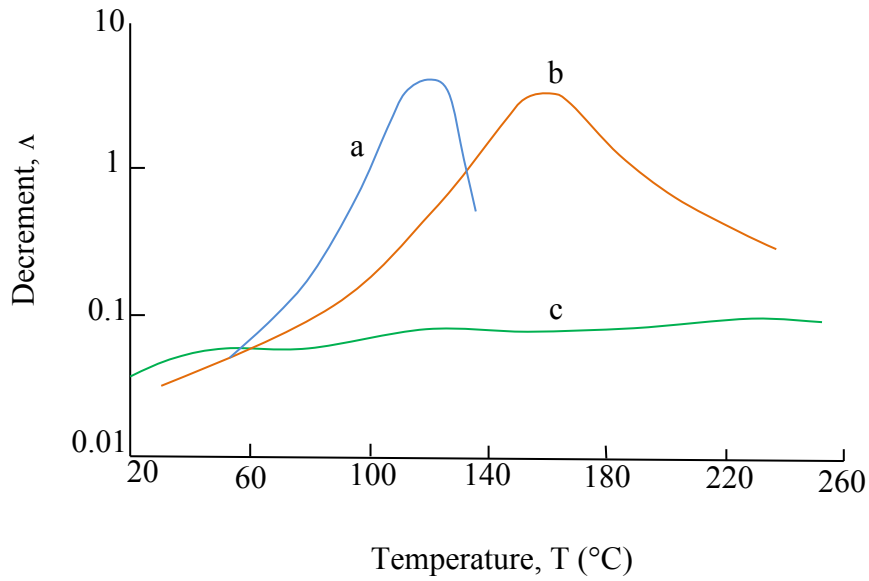

Figure 15 : temperature dependence of shear modulus (G)

**Note :**

**\*Cross-linking increases in the order a<b<c**

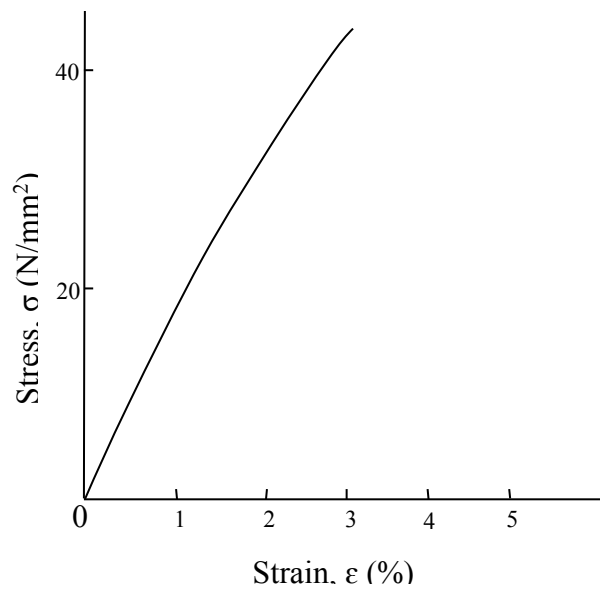

Figure 16: stress-strain curve for thermosets

<b>International Association Of Certified Practicing Engineers</b>	<b>ENGINEERING MATERIALS AND THEIR STRENGTH</b>	<b>Page 52 of 151</b>
	<b>CPE LEVEL I TRAINING MODULE</b>	
	<b>Rev: 02</b>	
		<b>Jan 2015</b>

### 3. Elastomers

One of the fascinating properties of the elastomeric materials is their rubber-like elasticity. That is, they have the ability to be deformed to quite large deformations, and then elastically spring back to their original form<sup>[7]</sup>. Elastomers are loosely cross-linked polymers that exhibit energy-elastic behavior at low temperature but do not exhibit viscous flow even at high temperature and its normal state (unextended) must be amorphous. Figure 17 and Figure 18 show a schematic curve of shear modulus and loss factor versus temperature for natural rubber, along with a schematic stress – strain curve.

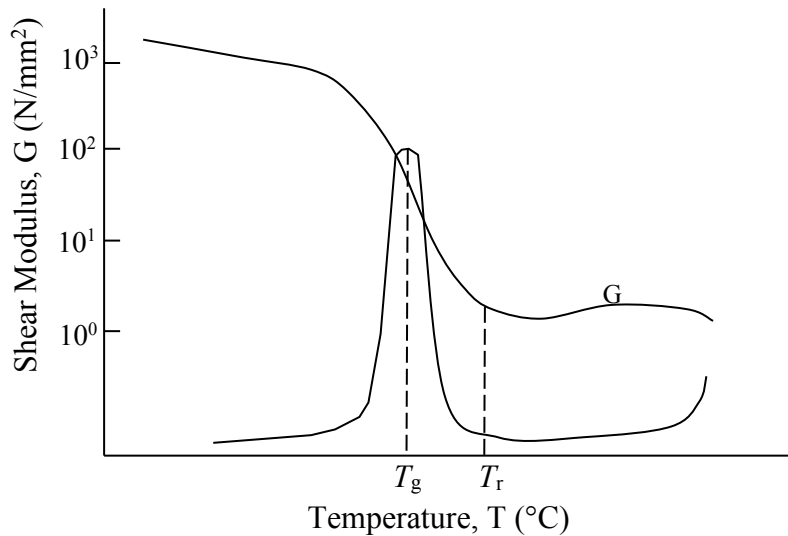

Figure 17 : shear modulus vs temperature (2)

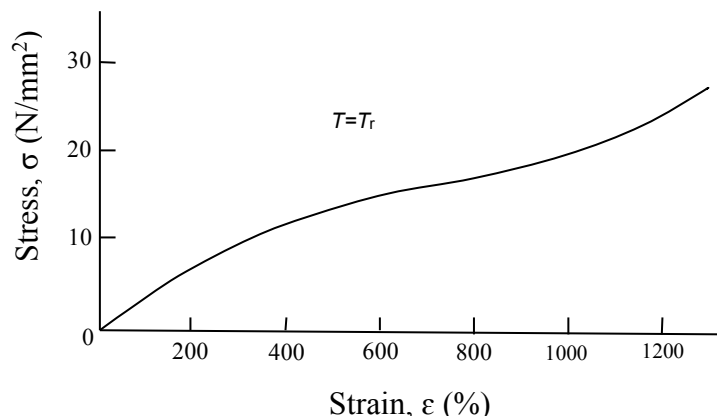

Figure 18 : stress vs strain curve for elastomers

<b>International Association Of Certified Practicing Engineers</b>	<b>ENGINEERING MATERIALS AND THEIR STRENGTH</b>  <b>CPE LEVEL I TRAINING MODULE</b>	Page 53 of 151
		Rev: 02
		Jan 2015

Above the glass transition temperature (20°C or lower), elastomers exhibit rubberlike behavior. In this range, mostly have shear moduli between ca. 0.1 and 100N/mm<sup>2</sup> and a high reversible deformability. The stress – strain curve has a characteristic “S” shape.

#### d. Miscellaneous Mechanical Characteristics

##### i. Tensile Strength

Tensile strength is the most common evaluation of polymer mechanical properties. The tensile stress ( $\sigma$ ) is recorded as a function of time t, with draw (strain ratio) formulated as :

$$\lambda = \frac{L}{L_0} \quad \text{Eq (3)}$$

and tensile strain (elongation),

$$\epsilon = \frac{(L - L_0)}{L_0} = \lambda - 1 \quad \text{Eq (4)}$$

Where,

- $\lambda$  = length ratio
- $\epsilon$  = tensile stain, m/m (in/in)
- L = final length, in (m)
- L<sub>0</sub> = initial length, in (m)

If the specimen is extended to L = 2.5 L<sub>0</sub> from its original length (L<sub>0</sub>), then it is said to have been drawn by 150%.

##### ii. Fracture

By the theory, fracture of brittle polymers generate free radicals. Since the probabilities of such homolyses depend on bond strengths, which also determining of tensile moduli, relationships must exist between the theoretical moduli and theoretical fracture strength of polymers. The lower the theoretical fracture strengths of most polymers are caused by many factors. Theoretical fracture strengths relate to infinitely long, completely aligned, immobile polymer chains. The reason for the lower than expected fracture strengths of

<b>International Association Of Certified Practicing Engineers</b>	<b>ENGINEERING MATERIALS AND THEIR STRENGTH</b>	<b>Page 54 of 151</b>
		<b>Rev: 02</b>
		<b>Jan 2015</b>
<b>CPE LEVEL I TRAINING MODULE</b>		

amorphous polymers is the presence of microvoids, which act as nuclei for cracks. Plastics exhibit three types of deformation and fracture behavior :

- Quasi-brittle fracture

The susceptibility of these materials to fracture when a crack is present may be expressed in terms of the plane strain fracture toughness. In this area the event of linearly elastic fracture mechanics (LEFM) offers a fairly good description even of viscoelastic materials. As deformation behavior becomes more strongly plastic to completely plastic, the corrections are no longer sufficient and the linearly elastic solution ceases to be meaningful.

- Fracture after Partial or Complete Shear Deformation

A ductile fracture, in contrast to a brittle one, is characterized by large amounts of macroscopic deformation. The deformation may arise through uniform elongation or, in true ductile fracture, by yielding or necking. The analogous behavior of metals and some plastics is underlined further by the occurrence of necking. In thermoplastics, one or several such necking zones migrate over the specimen until the whole has experienced yielding.

- Fracture after Deformation with the Formation of Crazes (Flow Zones)

Crazes or zones are planar inhomogeneities in a high polymer, produced by plastic deformation in the direction of an applied tensile stress. The planar surface of the craze forms perpendicular to the maximum principal tensile stress. A craze can be as large as 1 cm<sup>2</sup> in area but no more than 4 μm thick. Surface crazes display arched crack edges or dislocations. In contrast to a crack, a craze contains material in a highly stretched, unthinned state and behaves as an optically homogeneous medium. The craze stands out sharply against surrounding normal polymer material.

### iii. Resistance's Effect

Impact strength is the resistance of a material to impact. It is one of the many quantities used to characterize the strength of material under any conditions with all the test methods are thus standardized. Most test methods measure the energy required to break a notched or unnotched specimen. Impact speeds are range from 10<sup>-5</sup> – 10<sup>-1</sup> m/s in conventional tensile tests to 20 – 240 m/s for high-speed tensiles, elongation speeds are usually from 10<sup>-3</sup> to 10<sup>-4</sup> /s.

<b>International Association Of Certified Practicing Engineers</b>	<b>ENGINEERING MATERIALS AND THEIR STRENGTH</b>	<b>Page 55 of 151</b>
	<b>CPE LEVEL I TRAINING MODULE</b>	<b>Rev: 02</b>
		<b>Jan 2015</b>

Impact strengths is depend on an experimental conditions. The smaller the radius of the notch, the higher is the stress concentration at the tip and the lower is the impact strength. At very low temperature, all polymers all brittle. The mobility of chain segments increases with increasing temperature, allowing stresses to be relieved by shear-band or craze formation. Impact strengths increase with temperature, especially near the glass transition temperature. Polymer with additional transition temperatures below the glass transition temperatures are for the same reason almost always more impact resistant than polymers without such transitions. None entangled polymers exhibit very low impact strengths because no crazes can be formed. The impact behavior of polymer could be improved considerably by modification with rubber.

#### **iv. Stress Cracking**

Stress cracking (sometimes called stress corrosion, stress crazing) is the formation crazes under the physical action of chemicals, especially surfactans. Stress corrosion starts at polymer surfaces and proceeds into the interior until the polymer finally cracks. The appearance and the extent of stress cracking depend on the polymer – reagent interaction and the magnitude of the stress.

Effects are weak in nonwetting liquids but strong in polymer – liquid systems with solubility parameters of polymers and liquids matching each other and even more dramatic under tension in the presence of surfactans. Stress cracking decreases with increasing molar mass of the polymer since entanglements allow stresses to relax elastically cross-linked polymers are less prone to stress cracking or the same reason. Stress cracking is also reduce if polymer plasticizers are present in plastics due to the addtives which could increase the mobility of chain segments and thus the ability to relieve stress. The same action is responsible for the fact that no stress corrossions are observed above glass transition temperatures.

#### **v. Fatigue**

Materials could be destructed not only as an instant event but also by a static or continous loads after certain times and number of loadings. This fatigue is characterized by the fatigue limit (endurance) which the plastics are not damaged even after infinite time and the fatigue strength which indicates the load at which damage sets in after a certain time. Plastics may be subjected to static loads for certain times, after which their fracture strength are measured by tensile tests. The logarithms of strength of amorphous polymers usually decrease linearly with logarithms or time due to viscous flow.

<b>International Association Of Certified Practicing Engineers</b>	<b>ENGINEERING MATERIALS AND THEIR STRENGTH</b>  <b>CPE LEVEL I TRAINING MODULE</b>	Page 56 of 151
		Rev: 02
		Jan 2015

#### **vi. Hardness**

As in general, hardness is not a fundamental property of plastics, the concept is strongly subjective. It could be the most wide. Its acknowledge edged definition is resistance to the penetration of another, harder body. As in methods for metals, hardness testing on plastics employs a standard penetrator, often a hardened steel ball or steel pin, that is pressed by defined force into a plane surface of the material being tested, with the depth of penetration being measured.

The hardness of hard plastics is normally characterized by various Rockwell (such as ISO, ASTM) or ball indentation hardnesses (DIN, ISO). These methods measure the indentation of a polymer by a steel sphere under load and thus the compression set and the recoverable deformation. The plastic deformations of polymers increase with time (creep), whereas those of metals are time independent. Because of the short duration of the hardness test polymers exhibit relatively high Rockwell hardnesses.

The hardness of soft plastics are characterized by their durometer (ASTM) or various Shore hardnesses (ISO, DIN). These methods measure the resistance to penetration by a truncated cone (static methods). Hardness properties of metals and hard plastics are evaluated by another Shore hardness that uses the rebound of a small steel sphere (dynamic methods). All methods measure the hardness of surfaces, not of the interior of the specimen. The surface may, in example, be plasticized by humidity of the air. Crystallizable polymers may have lower surface hardnesses than interior hardnesses.

#### **vii. Friction**

Friction, the resistance against the relative movement of two bodies contact in each other is measured by the friction coefficient ( $\mu$ ). Friction depends in a complex and not understood way on both the surface roughness of the specimen and its mechanical properties. The rolling of hard bodies on soft materials is determined almost exclusively by deformation of the soft base. While Elastomers thus have fairly high friction coefficients of  $0.5 < \mu < 3.0$ , depending on the contacting body and its type of movement (rolling, sliding).

The concept of friction is often broken down into static and dynamic friction, even though perfectly static friction is impossible hard to implied. The term of static friction normally refers to the amount of force required to induce a relative motion between two surfaces in contact that is, what is measured is the frictional force with very slow movement. Dynamic friction means the force that will maintain a constant, perceptible, relative motion between contacting surfaces.

<b>International Association Of Certified Practicing Engineers</b>	<b>ENGINEERING MATERIALS AND THEIR STRENGTH</b>	Page 57 of 151
		Rev: 02
		Jan 2015
<b>CPE LEVEL I TRAINING MODULE</b>		

The sliding of hard bodies on other hard bodies occur on the tops of the microscopic surfaces, the true contact area is much smaller than the geometric one. The applied load thus acts on very small effective areas. Local stresses are high and the tops are leveled. Large adhesion forces exist between chemical groups of the resulting effective contact areas of both bodies, which must be overcome by breaking the bonds or by shearing one of the materials. Table 13 represents the friction coefficient of any materials including plastics, metals, and ceramics.

Table 13 : friction coefficient

Plastic	Friction coefficient of		
	Plastic on plastic	Plastic on steel	Steel on plastic
Poly(methyl methacrylate)	0.8	0.5	0.45
Polyestyrene	0.5	0.3	0.35
Polyethylene, HD	0.1	0.15	0.20
Polyethylene, LD	0.3		0.80
Polytetrafluoroethylene	0.04	0.04	0.10

#### e. Control of Mechanical Properties

Orientation of any materials (especially plastics) refers to the alignment of structural elements, in example of polymer chains of chain segments, crystalline regions, or domains. Orientation takes place in the initial production process or results from subsequent drawing and is frozen in on transformation to the solid state, with simultaneous occurrence of disorientation processes. A material usually exhibits greater strength and less elongation in the orientation direction. Orientation is used in the production of high-strength monofilaments (fibers and wires) and biaxially drawn films with high impact penetration strength.

Molecular orientation in polymers can be determined by wide-angle X-ray diffraction, birefringence, linear dichroism, acoustic velocity, or nuclear resonance. An approximate measure of orientation is the shrinkage at high temperature, which results mainly from the prior molecular alignments and is thus an entrop-elastic effect. Figure 19 represents how orientation influences the notched bar impact a bending strength of polystyrene.

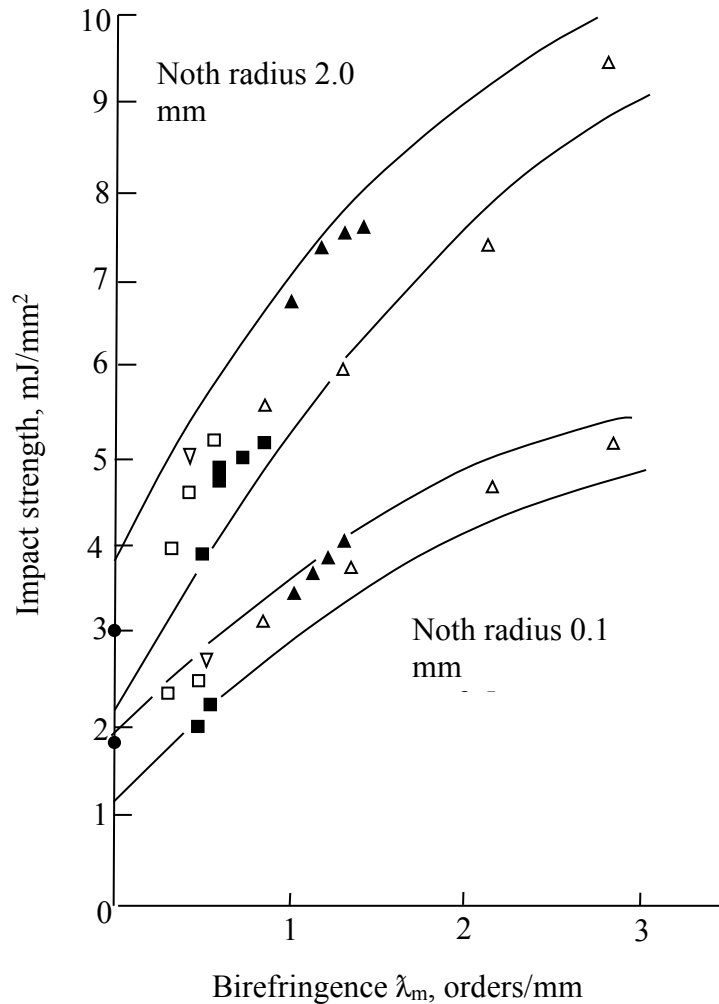

Figure 19 : influence of orientation

In polymerization processes, spherulite (grains in polycrystalline) size is often controlled by addition of nucleating agents in order to achieve desired properties, such as high rigidity or impact strength. Rigidity generally increases with increasing spherulite radius, whereas toughness decreases. The flow behavior, rigidity, and impact strength are improved. If only a reduction in rigidity is required, and no special demands are imposed on the energy absorption in impact loading, internal or external plasticization can be used. Internal

<b>International Association Of Certified Practicing Engineers</b>	<b>ENGINEERING MATERIALS AND THEIR STRENGTH</b>	<b>Page 59 of 151</b>
		<b>Rev: 02</b>
		<b>Jan 2015</b>
<b>CPE LEVEL I TRAINING MODULE</b>		

plasticization is the copolymerization of two compatible monomers whose glass transition temperatures differ greatly. External plasticization is a solvation process in which low molecular mass plasticizers are bound to polymer macromolecules.

### **C. Ceramics**

Most ceramics are compounds between metallic and nonmetallic elements for which the interatomic bonds are either totally ionic, or predominantly ionic but having some covalent character<sup>[7]</sup>. In general, ceramic materials used for engineering applications can be divided into two groups: traditional ceramics, and the engineering ceramics. Typically, traditional ceramics are made from three basic components: clay, silica (flint) and feldspar. For example bricks, tiles and porcelain articles. However, engineering ceramics consist of highly pure compounds of aluminium oxide ( $Al_2O_3$ ), silicon carbide (SiC) and silicon nitride ( $Si_3N_4$ )<sup>[16]</sup>.

#### **a. Classification of Ceramics**

Another important classification of ceramics is based on their application. There are described as follow.

##### **i. Glasses**

Glasses are a familiar group of ceramics – containers, windows, mirrors, lenses, etc. They are non-crystalline silicates containing other oxides, usually CaO, Na<sub>2</sub>O, K<sub>2</sub>O and Al<sub>2</sub>O<sub>3</sub> which influence the glass properties and its color. The most desirable trait of these materials is their optical transparency.

Typical property of glasses that is important in engineering applications is its response to heating. There is no definite temperature at which the liquid transforms to a solid as with crystalline materials. A specific temperature, known as glass transition temperature or fictive temperature is defined based on viscosity above which material is named as super cooled liquid or liquid, and below it is termed as glass.

##### **ii. Clays**

clay is the one of most widely used ceramic raw material. It is found in great abundance and popular because of ease with which products are made. Most of the clay-based products fall within two broad classifications; the structural clay products and the whitewares. Structural products include bricks, tiles, and sewer pipes. The whitewares

<b>International Association Of Certified Practicing Engineers</b>	<b>ENGINEERING MATERIALS AND THEIR STRENGTH</b>	<b>Page 60 of 151</b>
		<b>Rev: 02</b>
		<b>Jan 2015</b>
<b>CPE LEVEL I TRAINING MODULE</b>		

(white after the high-temperature firing) include porcelain, chinaware, pottery, and plumbing fixtures (sanitary ware).

### **iii. Refractories**

These are described by their capacity to withstand high temperatures without melting or decomposing; and their inertness in severe environments. Thermal insulation is also an important functionality of refractories.

Refractory materials are marketed in a variety of forms, but bricks are the most common. Typical applications include furnace linings for metal refining, glass manufacturing, metallurgical heat treatment, and power generation.

### **iv. Abrasive ceramics**

Abrasive ceramics are used to grind, wear, or cut away other material which necessarily is softer. Thus the prime requisite for this group of materials is hardness or wear resistance in addition to high toughness. As they may also be exposed to high temperatures, they need to exhibit some refractoriness. Diamond, silicon carbide, tungsten carbide, silica sand, aluminium oxide / corundum are some typical examples of abrasive ceramic materials.

### **v. Cements**

Several familiar ceramic materials are classified as inorganic cements: cement, plaster of paris, and lime, which, as a group, are produced in extremely large quantities. The characteristic feature of these materials is that when mixed with water, they form a paste that subsequently sets and hardens. Thus it is possible to form virtually any shape. They are also used as bonding phase, for example between construction bricks<sup>[7]</sup>.

<b>International Association Of Certified Practicing Engineers</b>	<b>ENGINEERING MATERIALS AND THEIR STRENGTH</b>	Page 61 of 151
		Rev: 02
		Jan 2015
<b>CPE LEVEL I TRAINING MODULE</b>		

vi. **Advanced ceramics**

Table 14 : classification of high-technology ceramics based on the functions

Function	Material	Uses
Electric functions	Insulation materials ( $\text{Al}_2\text{O}_3$ , BeO, MgO)	IC circuit, package, wiring substrate, resistor substrate.
	Ferroelectric material ( $\text{BaTiO}_3$ , $\text{SrTiO}_3$ )	Ceramic capacitor.
	Piezoelectric material (PZT)	Vibrator, Oscillator, Filter.
	Semiconductor materials ( $\text{V}_2\text{O}_5$ , SiC)	NTC thermistor, PTC thermistor, CTR thermistor.
	Ion-conducting materials ( $\text{ZrO}_3$ , $\beta$ - $\text{Al}_2\text{O}_3$ )	Solid electrolyte for sodium battery.
Magnetic functions	Soft ferrite	Magnetic recording head.
	Hard ferrite	Fractional-horsepower motor.
Optical functions	Translucent Alumina	High-Pressure sodium vapor lamp.
	Translucent Magnesia	Lighting tube.
	Translucent $\text{Y}_2\text{O}_3$ – $\text{ThO}_2$ ceramics	Laser materials.
	PLZT ceramics	Memory element, light valve.
Chemical functions	Gas Sensor ( $\text{ZnO}$ , $\text{Fe}_2\text{O}_3$ , $\text{SnO}_2$ )	Gas Leakage alarm, Hydrocarbon detector.
	Humidity sensor ( $\text{MgCr}_2\text{O}_4$ – $\text{TiO}_2$ )	Cooking control on microwave.
	Catalyst carrier (corderite)	Catalyst carrier.
	Organic catalyst	Enzyme carrier.
	Electrodes (borides, titanates, sulfides)	Chlorine production.

<b>International Association Of Certified Practicing Engineers</b>	<b>ENGINEERING MATERIALS AND THEIR STRENGTH</b>	Page 62 of 151
		Rev: 02
		Jan 2015
<b>CPE LEVEL I TRAINING MODULE</b>		

Continued from Table 14

Function	Material	Uses
Thermal functions	ZrO <sub>2</sub> , TiO <sub>2</sub> ceramics	Infrared radiator
Mechanical functions	Cutting tools (Al <sub>2</sub> O <sub>3</sub> , TiC)	Ceramic tool, cermet tool.
	Wear-resistant materials (Al <sub>2</sub> O <sub>3</sub> , ZrO <sub>2</sub> )	Mechanical seal, bearings.
	Heat-resistant materials (SiC, Al <sub>2</sub> O <sub>3</sub> )	Turbine blade, Heat Exchangers.
Biological functions	Alumina ceramics implanation hydroxyapatite bioglass	Artificial tooth root, bone and joint.

As in general, advanced ceramics used as components in processing equipment by virtue of such ceramic properties as special electromagnetic qualities, relative chemical inertness, hardness and strength, and temperature capabilities sometimes in combination. Table 14 shows a systemic classification of advanced ceramics based on its function. Ceramics are already widely used in process industries, especially where corrosion, wear, and heat resistance are important. An excellent examples are found in metallurgical refractories. The prominent constituents of advanced structural ceramics and structural materials involving ceramics as follows :

- Alumina
- Silicon carbide
- Silicon nitride
- Lithium aluminosilicates
- Ceramic composites
- Ceramic-coated materials

The materials above are widely implied in diesel, turbocharger, and gas-turbine engines, high temperature furnaces, and in the machines and equipment needed for manufacturing.

The technology of ceramic manufacturing rests on measurement of the structural and chemical properties of raw materials used in ceramic forming systems. Many sophisticated instruments and equally sophisticated techniques are available for evaluation of formula ingredients and of forming systems at various stages of manufacture.

<b>International Association Of Certified Practicing Engineers</b>	<b>ENGINEERING MATERIALS AND THEIR STRENGTH</b>	Page 63 of 151
		Rev: 02
		Jan 2015
<b>CPE LEVEL I TRAINING MODULE</b>		

**b. Characterization of ceramics**

“Characterization describes those features of the composition and structure (including defects) of a material that are significant for a particular preparation, study of properties, and suffice for the reproduction of the material.” The characterization involves a direct relation between test results and properties. The mere taking of data is no characterization unless the test procedure serves a particular function in predicting properties of the material under test. Table 15 represents a complete characterizing descriptions of examples of formulas used in making of several products.

Table 15 : characterization of two clay-based

<b>Properties</b>	<b>Vitreous sanitary ware</b>	<b>Vitreous China</b>
Chemical, wt%		
SiO <sub>2</sub>	65.0*	69.4*
Al <sub>2</sub> O <sub>3</sub>	23.1*	19.5*
Fe <sub>2</sub> O <sub>3</sub>	0.44	0.30*
TiO <sub>2</sub>	0.28	0.14*
CaO	0.33	1.33*
MgO	0.13	0.11
K <sub>2</sub> O	2.68*	1.45*
Na <sub>2</sub> O	2.41*	1.14*
Ignition loss	5.67*	6.46
Mole of flux	0.0766*	0.0604*
Minerals, wt%		
Smectice	3.7	3.0
Kaolin constituents	32.7	33.3
Mica	8.8*	5.8*
Free Quartz	23.7*	39.6*
Organic	0.46*	0.23*
Auxiliary flux		2.3
Particle size		
% < 20 μm	76	76
% < 5 μm	47	45
% < 2 μm	33	36
% < 1 μm	25	28*
% < 0.5 μm	19	21
Surface		
MBI, meq/100g	3.3*	2.7*

\*Key factor

<b>International Association Of Certified Practicing Engineers</b>	<b>ENGINEERING MATERIALS AND THEIR STRENGTH</b>	Page 64 of 151
		Rev: 02
		Jan 2015
<b>CPE LEVEL I TRAINING MODULE</b>		

### c. Properties of Ceramics

The properties of ceramic materials, like all materials, are dictated by the types of atoms present, the types of bonding between the atoms, and the way the atoms are packed together. The type of bonding and structure helps determine what type of properties a material will have.

Ceramics usually have a combination of stronger bonds called ionic (occurs between a metal and nonmetal and involves the attraction of opposite charges when electrons are transferred from the metal to the nonmetal); and covalent (occurs between two nonmetals and involves sharing of atoms). The strength of an ionic bond depends on the size of the charge on each ion and on the radius of each ion. The greater the number of electrons being shared, is the greater the force of attraction, or the stronger the covalent bond.

These types of bonds result in high elastic modulus and hardness, high melting points, low thermal expansion, and good chemical resistance. On the other hand, ceramics are also hard and often brittle (unless the material is toughened by reinforcements or other means), which leads to fracture<sup>[25]</sup>.

Table 16 constitutes mechanical properties of a number of representative ceramic products. For all cases, there is a characteristic direct transition from a small deformation, with no or small plastic deformation, to fracture. Irreversible deformations from above the elastic region up to fracture may be because of the viscous process within the particle structure.

Table 16 : mechanical properties of ceramic materials

Type of Material	Compressive strength, MPa	Flexural strength, MPa	Modulus of elasticity, Gpa
Solid brick	10 – 25	5 - 10	5 – 20
Roof tile	10 – 25	8 – 15	5 – 20
Steatite	850 – 1000	140 – 160	1 – 3
Silica refractories, 96 – 97% SiO <sub>2</sub>	15 – 40	30 – 80	8 – 14
Fireclay refractories, 10 – 44% Al <sub>2</sub> O <sub>3</sub>	10 – 80	5 -15	20 – 45
Corundum refractories, 75 – 90% Al <sub>2</sub> O <sub>3</sub>	40 – 200	10 – 150	30 – 120
Forsterite refractories	20 – 40	5 – 10	25 – 30

<b>International Association Of Certified Practicing Engineers</b>	<b>ENGINEERING MATERIALS AND THEIR STRENGTH</b>	Page 65 of 151
		Rev: 02
	<b>CPE LEVEL I TRAINING MODULE</b>	Jan 2015

Continued from Table 16

Type of Material	Compressive strength, MPa	Flexural strength, MPa	Modulus of elasticity, Gpa
Magnesia refractories	40 – 100	8 – 200	30 – 35
Zircon refractories	30 – 60	80 – 200	35 – 40
Whiteware	30 – 40	20 – 25	10 – 20
Stoneware	40 – 100	20 – 40	30 – 70
Electrical porcelain	350 – 850	90 – 145	55 – 100
Capacitor ceramics	300 – 1000	90 – 160	

Ceramics also have other properties. There are high melting point (°C), thermal expansion coefficient, and resistivity value. Melting point is given in table 17 that is taken from ceramic oxides as example.

Table 17 : melting points of ceramic oxides

Constituent	Melting Point (°C)
Al <sub>2</sub> O <sub>3</sub>	2050
MgO	2800
CaO	2600
SiO <sub>2</sub>	1780
ZrO <sub>2</sub>	2700
Cr <sub>2</sub> O <sub>3</sub>	2265
Fe <sub>3</sub> O <sub>4</sub>	1600
FeO	130
MgO . Al <sub>2</sub> O <sub>3</sub>	2135
2 MgO . SiO <sub>2</sub>	1890
2 Al <sub>2</sub> O <sub>3</sub> . 2 SiO <sub>2</sub>	1810
ZrO <sub>2</sub> . SiO <sub>2</sub>	1775

Table 18 cites thermal expansion coefficients for a number of ceramic product constituents. Due to the high melting points, these material usually have a low coefficients of thermal expansion. The anisotropic structure results from polycrystalline mixed phased and varying amounts of glassy phases, which explains the relatively poor thermal-shock resistance. Most ceramic products have thermal conductivities lower than platinum but higher than insulating firebrick or organic polymers for an example.

<b>International Association Of Certified Practicing Engineers</b>	<b>ENGINEERING MATERIALS AND THEIR STRENGTH</b>	Page 66 of 151
		Rev: 02
		Jan 2015
<b>CPE LEVEL I TRAINING MODULE</b>		

Table 18 : thermal expansion coefficient

Component	Temperature Range, °C		
	20 – 300	20 – 900	20 – 1400
Silica	36.5	15.5	10.0
Magnesite	10	12.7	14.2
Chrome magnesite	8.3	9.4	10.5
Chromite	8.3	9.1	9.5
Corundum 99	7.3	7.2	*
Corundum 90	4.3	5.2	6.5
Zircon	2.7	3.8	**
Silimanite	3.3	4.4	4.8
Silicon carbide	1.6	3.5	4.4

\* 7.9 over the range 20 – 1200 °C.

\*\* 4.5 over the range 20 – 1200 °C.

Resistivity of several number from ceramic products are deserved in Table 19. This kind of properties generally serve as electrical insulation purposes. Their resistivities are of the order of  $10^{12} - 10^{13}$  Ωcm, some orders of magnitude are higher than for metals.

Table 19 : resistivity values

Ceramic Material	Resistivity, Ωcm
Insulators	
Low-voltage porcelain	$10^{12} - 10^{14}$
Steatite porcelain	$10^{14}$
Mullite porcelain	$10^{13}$
Cordierite porcelain	$10^{13}$
Zircon porcelain	$10^{14}$
Alumina porcelain	$10^{16}$
Silica	$10^{19}$
Semiconductors	
Silicon carbide	10
Boron carbide	0.5
Ferric oxide	$10^{-2}$

Table 20 provides a tabulation of mechanical and thermal properties of materials implied in making advanced ceramics. The temperature for which the values are valid in the room temperature condition.

<b>International Association Of Certified Practicing Engineers</b>	<b>ENGINEERING MATERIALS AND THEIR STRENGTH</b>	Page 67 of 151
		Rev: 02
		Jan 2015
<b>CPE LEVEL I TRAINING MODULE</b>		

Table 20: properties of advanced ceramics

<b>Material</b>	<b>Crystal Structure</b>	<b>Theoretical density, mg/m<sup>3</sup></b>	<b>Knoop or Vickers hardness, GPa</b>	<b>Transverse rupture strength, MPa</b>	<b>Fracture toughness K<sub>IC</sub>, MPa.m<sup>0.5</sup></b>
Alumina, Al <sub>2</sub> O <sub>3</sub>	Hexagonal	3.97	18 – 23	276 – 1034	2.7 – 4.2
Mullite	Orthorhombic	2.8		185	2.2
Partially stabilized ZrO <sub>2</sub>	Cubic, Monoclinic, Teetragonal	5.70 – 5.75	10 – 11	600 – 700	8 – 9
TiO <sub>2</sub>	Tetragonal (rutile)	4.25	7 – 11	69 – 103	2.5
SiC	Hexagonal (α) Cubic (β)	3.21	20 – 30	230 – 825 (hot pressed)	4.8 – 6.1
Si <sub>3</sub> N <sub>4</sub>	Hexagonal (α) Hexagonal (β)	3.18 – 3.19	8 – 19	700 – 1000 (hot pressed)	3.6 – 6.0
TiN	Cubic	5.43 – 5.44	16 – 20		
<b>Material</b>	<b>Young's modulus, GPa</b>	<b>Thermal expansion, 10<sup>-6</sup> / K</b>	<b>Thermal conductivity</b>		<b>Specific Heat, J/kg.K</b>
			<b>400 K</b>	<b>1400 K</b>	
Alumina, Al <sub>2</sub> O <sub>3</sub>	380	7.2 – 8.6	27.2	5.8	1088
Mullite	145	5.7	5.2	3.3	1046
Partially stabilized ZrO <sub>2</sub>	205	8.9 – 10.6	1.8 – 2.2		400
TiO <sub>2</sub>	283	9.4	8.8	3.3	799
SiC	207 – 483	4.3 – 5.6	63 – 155	21 – 33	628 – 1046
Si <sub>3</sub> N <sub>4</sub>	304	3.0	9 – 30		400 – 1600
TiN	251	8.0	24	67.8*	628

\*at 1677 K.

<b>International Association Of Certified Practicing Engineers</b>	<b>ENGINEERING MATERIALS AND THEIR STRENGTH</b>	Page 68 of 151
	<b>CPE LEVEL I TRAINING MODULE</b>	Rev: 02
		Jan 2015

#### d. The Griffith Equation

One of the key to understanding the mechanical properties of ceramics is the Griffith theory for failure of brittle materials. Not like the other materials such as metals and polymers, ceramics are extremely brittle and therefore extremely sensitive to the presence of any sort of flaw on the surface or in the bulk of ceramic. Since polycrystalline ceramics are generally fabricated by sintering a powder compact at high temperature, the flaws might arise from nonuniformities in the packing of the powder or accidental inclusions in the compact.

The Griffith criterion states that if the flaw is larger than a critical size, then the rate of release of elastic strain energy is greater than the rate of gain of surface energy and the flaw will grow (crack extension). The growth is catastrophic because as the crack grows longer, the driving force becomes greater. The Griffith criterion is a necessary but not sufficient condition for growing a crack event. Orowan estimated this stress and found that for a sharp crack the Griffith stress was sufficient to break the bonds. The Griffith equation could be formulated as

$$\sigma_t = \sqrt{\frac{2E\gamma}{\pi C}} \quad \text{Eq (5)}$$

Where,

- $\sigma_t$  : Fracture stress, psi (Pascal / N/m<sup>2</sup>)
- E : Young's Modulus, psi (Pascal / N/m<sup>2</sup>)
- $\gamma$  : The effective surface energy
- C : Length of the surface (2C is for an interior flaw), in (m)

There is one assumption that needs to be implied when using the Griffith equation. The equation only works for the increasing surface area of the crack acts to resist crack growth. Besides, other features outside surface energy resist the propagation of the crack. Plastic deformation near the tip of the crack, crack bridging, and crack deflection. Generally the contribution is included in  $\gamma$ , which is then renamed by the fracture energy ( $\gamma_t$ ). The Griffith equation is sometimes written in terms of the critical stress intensity factor described as

$$K_c = Y\sigma_t\sqrt{C} \quad \text{Eq (6)}$$

<b>International Association Of Certified Practicing Engineers</b>	<b>ENGINEERING MATERIALS AND THEIR STRENGTH</b>	Page 69 of 151
		Rev: 02
		Jan 2015
<b>CPE LEVEL I TRAINING MODULE</b>		

Where Y is a dimensionless constant that depends on the geometry of loading and the crack configuration. The fracture stress is then rearrange as

$$\sigma_t = \frac{1}{Y} \sqrt{2E\gamma/C} = \frac{K_C}{Y\sqrt{C}} \quad \text{Eq (7)}$$

The second form of the Griffith equation is strongly useful in filed application because the  $K_C$  could be measured by a various fracture techniques. Table 21 cited how the fracture stress and the critical flaw size are related for a promising structural ceramic such as hot-pressed silicon carbide (SiC). This table also indicated that the flaw size for the high-strength ceramics is very small and that careful manufacturing techniques are necessary to avoid accidentally producing such small flaws un polycrystalline materials.

Table 21 : fracture strength vs flaw size

$\sigma_t$ , MPa	C, $\mu\text{m}$
1000	5
500	20
250	80
100	500
50	2025

The  $K_C$  value is really an indicator of how brittle or tough the material is. Several method had been used to increase  $K_C$  to high as  $10 - 15 \text{ MPa}^{0.5}$ . These high fracture toughnesses have been achieved with ceramic – ceramic composites. Continuous fiber composites, usually fabricated from woven ceramic cloth, are almost completely insensitive to flaws. Hence, they are strongly dependent on the mean strength of the fibers.

#### e. Failure

Ceramics do not under go plastic deformation at room temperature as do as metals. Plastic deformation in both metals and ceramics results from microscopic defects called dislocations. These dislocations move easily in the presence of a stress field in metals, but they do not move easily in ceramics. The stress at which plastic deformation could take place in ceramics is much higher than the fracture stress. As consequences, the strain to failure in ceramics is generally on the order of only small windows (0.1%) and ceramics can only be used when the stress is safely below the fracture stress.

<b>International Association Of Certified Practicing Engineers</b>	<b>ENGINEERING MATERIALS AND THEIR STRENGTH</b>	<b>Page 70 of 151</b>
		<b>Rev: 02</b>
	<b>CPE LEVEL I TRAINING MODULE</b>	<b>Jan 2015</b>

Safe design of ceramics in tensile or bending load applications requires knowledge of the necessary safety factor. To predicted the safety factor properly, the Weibull equation usually used. The Weibull equation is the most common statistics to estimate the value of safety factor for designing the ceramics. The Weibull equation can be formulated as

$$\ln\left(\frac{1}{(1-P_t)}\right) = \ln V + m \cdot \ln(\sigma_t - \sigma_\mu) - m \cdot \ln \sigma_0 \quad \text{Eq (8)}$$

Where,

- $P_t$  : Probability of the failure of a part subject to the stress
- $V$  : Volume sample under the tensile stress
- $\sigma_\mu$  : The stress of zero probability of failure (in most cases, the value is 0) psi (Pascal / N/m<sup>2</sup>)
- $\sigma_0$  : Normalizing parameter of no physical significance psi (Pascal / N/m<sup>2</sup>)
- $m$  : Weibull's modulus constant

This equation estimates that the probability of failure at a certain stress is related to the volume of the material under stress. Such a relationship between volume and stress, has been verified experimentally. The equation might be linearized by plotting  $\ln \ln (1/(1 - P_t))$  vs  $\ln \sigma_t$ , allowing the probability of failure at any given stress to be estimated by extrapolating a straight line. This termed often called a Weibull Plot (Figure 20).

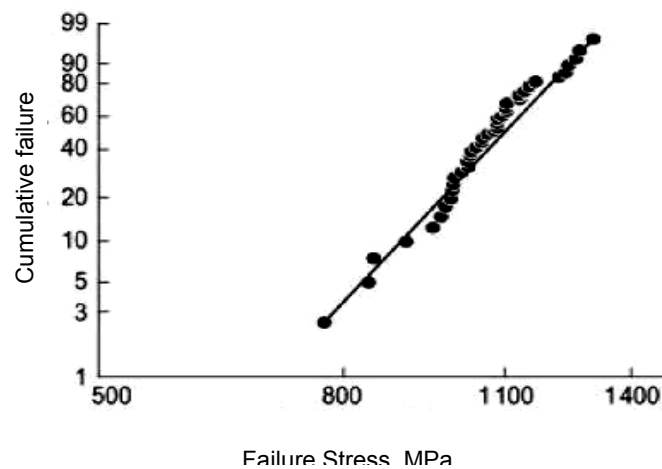

Figure 20: Weibull Plot

<b>International Association Of Certified Practicing Engineers</b>	<b>ENGINEERING MATERIALS AND THEIR STRENGTH</b>	<b>Page 71 of 151</b>
	<b>CPE LEVEL I TRAINING MODULE</b>	
	<b>Jan 2015</b>	

An extra important concern in design is slow crack growth. The crack grows under stress in the presence of atmospheric moisture. The velocity  $v$  of crack growth is given by the equation below

$$v = \alpha K^N \quad \text{Eq (53)}$$

Where,

- K : Stress intensity factor
- $\alpha$  : A constant
- N : Velocity exponent

#### f. Temperature's Effect

Figure 21 illustrated the effect of temperature on the strength of ceramics. The strength on ceramic is reduced as the temperature rises. The temperature at which this decrease in strength begins depends on the material. In materials with a cubic crystal symmetry, such as MgO or UO<sub>2</sub>, the temperature at which the strength begins to drop is generally low, but in Al<sub>2</sub>O<sub>3</sub> case, the strength drops off little up 1000°C. At high temperatures the strength depends on the rate which the stress is implied.

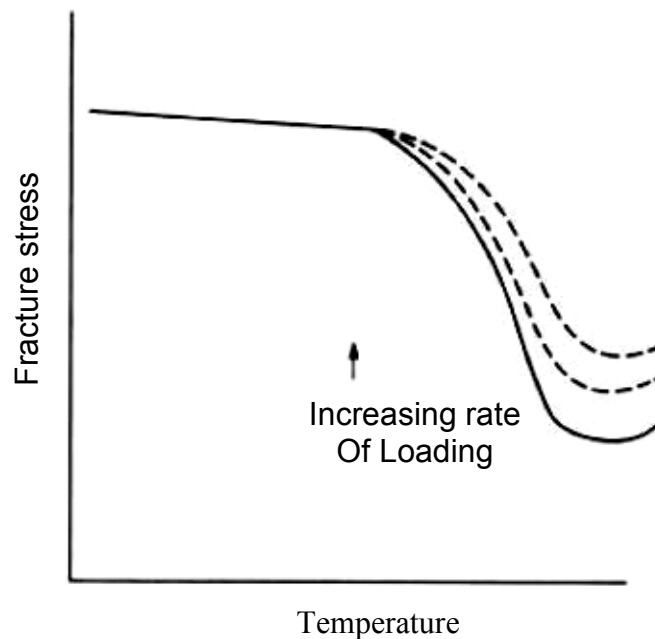

Figure 21 : temperature's effect

<b>International Association Of Certified Practicing Engineers</b>	<b>ENGINEERING MATERIALS AND THEIR STRENGTH</b>	<b>Page 72 of 151</b>
	<b>CPE LEVEL I TRAINING MODULE</b>	
	<b>Rev: 02</b>	
		<b>Jan 2015</b>

Above one-half the melting temperature, creep (slow time-dependent deformation) becomes appreciable. Since many of the important applications of ceramics are high-temperature applications, creep is important. Most fine-grained polycrystalline stresses deform according to one of the following two equations :

- The Nabarro – Herring equation  
The Nabarro – Herring equation can be determined by :

$$\dot{\epsilon} = \frac{10\Omega\sigma D_v}{kTd^2} \quad \text{Eq (9)}$$

- The Coble equation  
The Coble equation is obtained by :

$$\dot{\epsilon} = \frac{50\Omega\sigma w D_b}{kTd^3} \quad \text{Eq (10)}$$

Where,

- $\dot{\epsilon}$  : Creep rate
- $\Omega$  : Vacancy volume
- $\sigma$  : Applied stress
- $D_v$  : Volume self-diffusion coefficient
- $d$  : Grain diameter
- $k$  : Boltzmann's constant
- $T$  : Temperature (K)
- $w$  : The effective width of the grain boundary
- $D_b$  : Grain boundary diffusion coefficient

If ceramic contains a glassy grain boundary phase, then creep rates are somewhat higher than those given in these equations. If high creep resistance is desired, the glassy phase should be eliminated or high-temperature viscous glass should be used. Limitation-availability to withstand at high temperature for ceramics material often called *thermal shock*. As an example of thermal shock is a rapid drop in temperature. Their lack or thermal shock resistance is primarily because of their inability to accomodate the strain caused by a rapidly cooling surface adjacent to a hot interior. The low thermal conductivity of ceramics contributes to this lack of thermal shock resistance. The critical temperature drop ( $\Delta T_c$ )

<b>International Association Of Certified Practicing Engineers</b>	<b>ENGINEERING MATERIALS AND THEIR STRENGTH</b>	Page 73 of 151
		Rev: 02
		Jan 2015
<b>CPE LEVEL I TRAINING MODULE</b>		

through which a material may be shocked without exceeding the fracture stress at the surface is given by the equation.

$$\Delta T_c = \frac{\sigma_f(1-\nu)}{\psi E \alpha} \quad \text{Eq (11)}$$

Where,

- $\alpha$  : Thermal coefficient of expansion
- $\nu$  : Poisson's ratio
- $\psi$  : Factor depending on thermal conductivity, particle size, and heat transfer coefficient
- $E$  : Young's Modulus, psi (Pascal / N/m<sup>2</sup>)
- $\sigma_f$  : Stress, psi (Pascal / N/m<sup>2</sup>)

### **g. Fabrication and Processing of Ceramics**

Most ceramic products are made from ceramic powders through powder processing starting with ceramic powders. The powder processing of ceramics is very close to that of metals, powder metallurgy. However there is an important consideration in ceramic-forming that is more prominent than in metal forming: it is dimensional tolerance. Post forming shrinkage is much higher in ceramics processing because of the large differential between the final density and the as-formed density.

One chief concern in the application of ceramic materials is the method of fabrication. There are typically two methods to fabricate ceramic materials, those are fabrication of glass product and clay product. They are described as follow.

#### **i. Fabrication and processing of glass product**

Glass is produced by heating the raw materials to an elevated temperature above which melting occurs. Most commercial glasses are of the silica–soda–lime variety; the silica is usually supplied as common quartz sand, whereas Na<sub>2</sub>O and CaO are added as soda ash (Na<sub>2</sub>CO<sub>3</sub>) and limestone (CaCO<sub>3</sub>). Four different forming methods are used to fabricate glass products. They are<sup>[7]</sup> :

<b>International Association Of Certified Practicing Engineers</b>	<b>ENGINEERING MATERIALS AND THEIR STRENGTH</b>	<b>Page 74 of 151</b>
		<b>Rev: 02</b>
	<b>CPE LEVEL I TRAINING MODULE</b>	<b>Jan 2015</b>

a) Pressing

Pressing is used in the fabrication of relatively thick-walled pieces such as plates and dishes. The glass piece is formed by pressure application in a graphite-coated cast iron mold having the desired shape; the mold is ordinarily heated to ensure an even surface. This method is done by way: the raw gob of glass is formed by mechanical pressing in a mold.

b) Blowing

Some glass blowing is done by hand, especially for art objects, the process has been completely automated for the production of glass jars, bottles, and light bulbs. This method is implemented by way: the raw gob of glass is formed by blow mold and forced to conform to the mold contours by the pressure created from a blast of air.

c) Drawing

Drawing is used to form long glass pieces such as sheet, rod, tubing, and fibers, which have a constant cross section.

The following figures are pressing and blowing methods which are shown in figure 22.

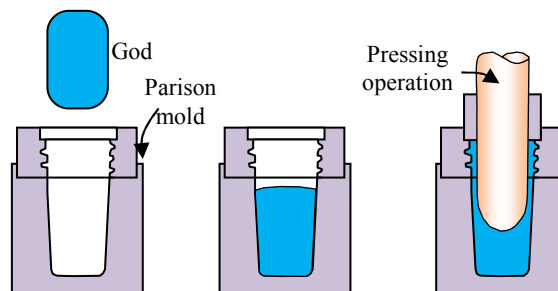

a. pressing method

<b>International Association Of Certified Practicing Engineers</b>	<b>ENGINEERING MATERIALS AND THEIR STRENGTH</b>	<b>Page 75 of 151</b>
		<b>Rev: 02</b>
	<b>CPE LEVEL I TRAINING MODULE</b>	<b>Jan 2015</b>

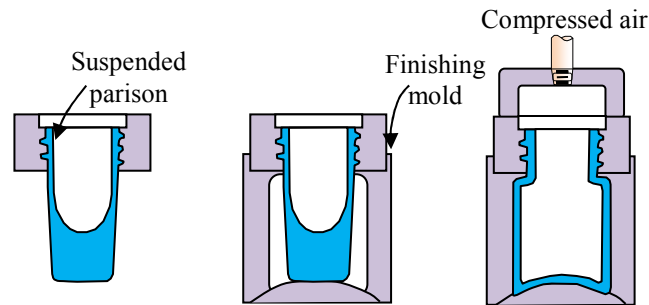

b. blowing method

Figure 22 : schematic diagram of pressing and blowing processes

## ii. Fabrication and processing of clay product

Clays are aluminosilicates, being composed of alumina ( $\text{Al}_2\text{O}_3$ ) and silica ( $\text{SiO}_2$ ), that contain chemically bound water. The as-mined raw materials usually have to go through a milling or grinding operation in which particle size is reduced; this is followed by screening or sizing to yield a powdered product having a desired range of particle sizes.

A powder is a collection of fine particles. Synthesis of powder involves getting it ready for shaping by crushing, grinding, separating impurities, blending different powders, drying to form soft agglomerates. Different techniques such as compaction, tape casting, slip casting, injection molding and extrusion are then used to convert processed powders into a desired shape to form what is known as green ceramic. The green ceramic is then consolidated further using a high-temperature treatment known as sintering or firing<sup>[16]</sup>. Common shaping technique utilized for forming clay-based compositions is slip casting.

<b>International Association Of Certified Practicing Engineers</b>	<b>ENGINEERING MATERIALS AND THEIR STRENGTH</b>	<b>Page 76 of 151</b>
		<b>Rev: 02</b>
	<b>CPE LEVEL I TRAINING MODULE</b>	<b>Jan 2015</b>

Slip casting is illustrated in figure 23.

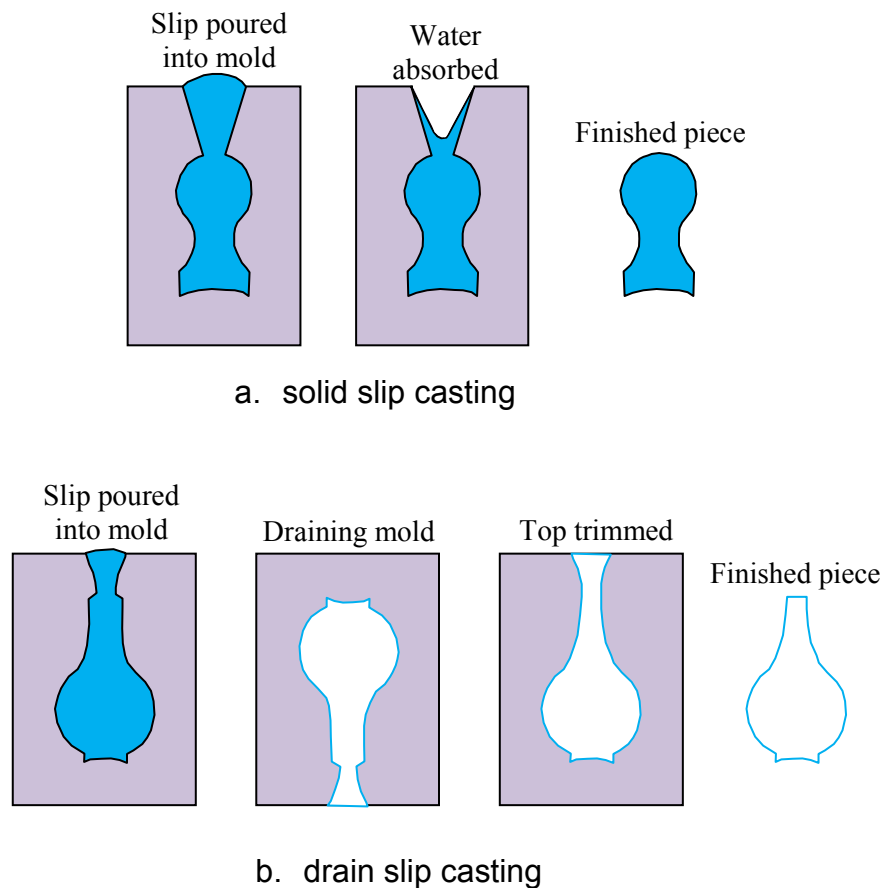

Figure 23 : slip casting

#### D. Composites

The term of “composites” is cited as in the technical sense to describe a product that arises from incorporation of more than one basic from material structure into a-new-kind substance, this substance is often called ‘the matrix’. This matrix could be formed by any material structures such as particles, fibers, whiskers, lamellae or even a mesh. Matrix which surrounds the other phase, often called the dispersed phase or reinforcement phase. The properties of composites are a function of the properties of the constituent phases, their relative amounts, and the geometry of the dispersed phase.

Dispersed phase geometry means the shape of the particles and the particle size, distribution, and orientation; these characteristics are represented in Figure 24.

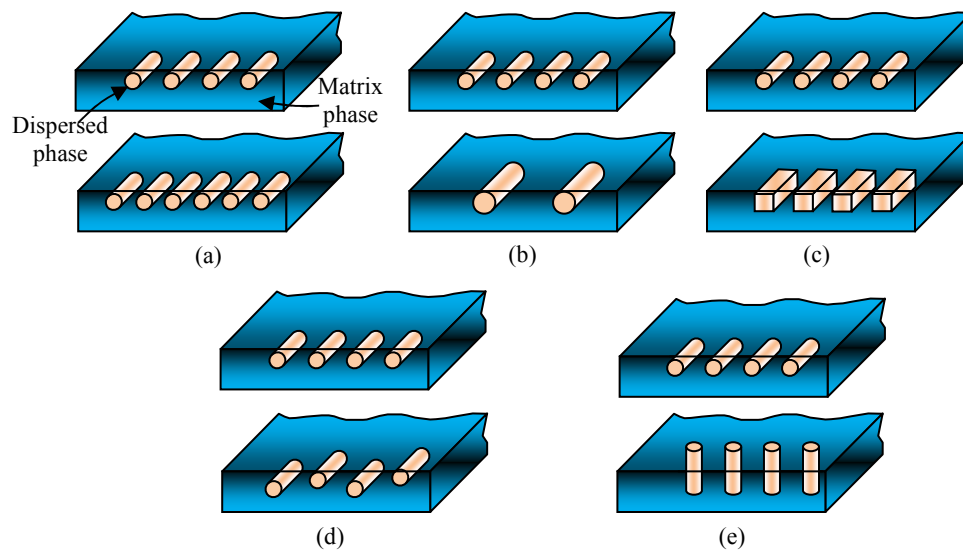

Figure 24 : dispersed phase geometry

### a. Material Classification of Composite

Almost all of the known structural material types can play a part of the matrix. The volume fraction of fibers in a composite rarely exceeds 0.5, the general appearance of the material is conferred by the matrix. The material classification of a composite substances could be classified at least five particulate groups, there are : High polymers, Metals, Ceramics, Cement, and Rubber.

#### 1. High polymers

This substances usually used as a building materials. Most often encountered are unsaturated polyester and epoxy resins. Other examples including polycrylate dental materials containing silicate particles and polypropylene to which glass fibers have been added for use in shatterproof safety glass.

<b>International Association Of Certified Practicing Engineers</b>	<b>ENGINEERING MATERIALS AND THEIR STRENGTH</b>	Page 78 of 151
		Rev: 02
		Jan 2015
<b>CPE LEVEL I TRAINING MODULE</b>		

## 2. Metals

Metals are less used for an ordinary temperature composite materials due to its heavy weight. The only exception is for light-metal alloy that strengthen by incorporation of Boron, SiC, or carbon fibers. Cobalt-based alloys that contained WC/TiC (hardened alloy) usually employed for cutting tools.

## 3. Ceramics

Ceramics containing fibrous materials and have come into use as lightweight bulletproof shields (such as helmets, vests, and helicopter seats). Ceramics material also have been used for civilian applications.

## 4. Cement

Cement containing asbestos, plastic, glass, or threads has numerous uses in the construction industry, especially for poured concrete structures. Also noteworthy is the high impact resistance of concrete reinforced with polypropylene fibers.

## 5. Rubber

The rubber can also serve as the basis for composites. This compounds usually used in preparation for magnetic particles.

### **b. Classification of composites**

Composite materials are classified based on type of matrix material and size and shape of dispersed phase. Type of matrix material includes metal matrix composites (MMC), polymer matrix composites (PMC) and ceramic matrix composites (CMC). Whereas, size and shape of dispersed phase includes particle-reinforced composites, fiber-reinforced composites and structural composites. The following sections highlight the mechanics of composites, which depend on size-and-shape of dispersed phase.

#### **i. Particle-reinforced composites**

This class of composites is most widely used composites mainly because they are widely available and cheap. Subclassifications of particle-reinforced composites are particulate composites and dispersion-strengthened composites. These two classes are distinguishable based upon reinforcement or strengthening mechanism.

<b>International Association Of Certified Practicing Engineers</b>	<b>ENGINEERING MATERIALS AND THEIR STRENGTH</b>	Page 79 of 151
		Rev: 02
		Jan 2015

**a) Particulate composite**

Particulate composites contain large amounts of comparatively coarse particles. These composites are designed to produce unusual combinations of properties rather than to improve the strength. Particles can have quite a variety of geometries, but they should be of approximately the same dimension in all directions (equiaxed). For effective reinforcement, the particles should be small and evenly distributed throughout the matrix. Mechanical properties, such as elastic modulus, of particulate composites achievable are in the range defined by rule of mixtures that can be given as follow

Upper bound is represented by

$$E_c(u) = E_m V_m + E_p V_p \quad \text{Eq (12)}$$

And lower bound is represented by

$$E_c(l) = \frac{E_m E_p}{V_m E_m + V_p E_m} \quad \text{Eq (13)}$$

Where,

- E = elastic modulus, psi (Pascal / N/m<sup>2</sup>)
- V = volume fraction, dimensionless
- c = composite
- m = matrix
- p = particulate phase

Figure 25 plots upper and lower bound  $E_c$  versus  $V_p$  curves for a copper tungsten composite as example.

<b>International Association Of Certified Practicing Engineers</b>	<b>ENGINEERING MATERIALS AND THEIR STRENGTH</b>	<b>Page 80 of 151</b>
	<b>CPE LEVEL I TRAINING MODULE</b>	
	<b>Rev: 02</b>	
		<b>Jan 2015</b>

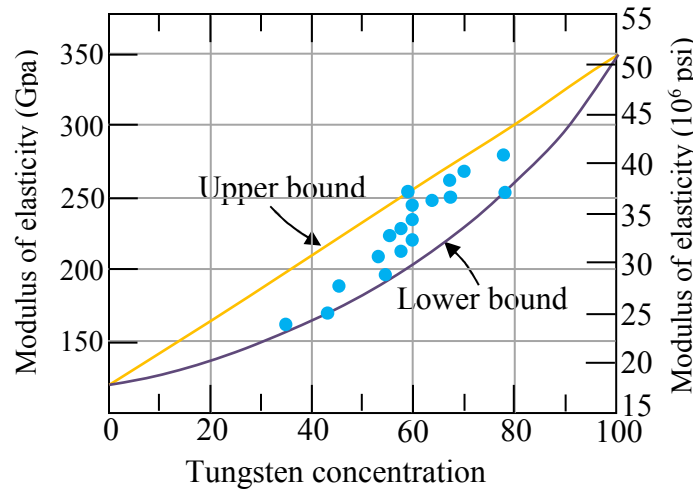

Figure 25 : modulus of elasticity versus volume percent

Particulate composites are used with all three material types – metals, polymers and ceramics. Cermets contain hard ceramic particles dispersed in a metallic matrix. Eg.: tungsten carbide (WC) or titanium carbide (TiC) embedded cobalt or nickel used to make cutting tools. Polymers are also frequently reinforced with various particulate materials such as carbon black. When added to vulcanized rubber, carbon black enhances toughness and abrasion resistance of the rubber. Aluminium alloy castings containing dispersed SiC particles are widely used for automotive applications including pistons and brake applications.

Concrete is most commonly used particulate composite. It consists of cement as binding medium and finely dispersed particulates of gravel in addition to fine aggregate (sand) and water. It is also known as Portland cement concrete. Its strength can be increased by additional reinforcement such as steel rods/mesh.

### b) Dispersion-strengthened composites

In dispersion-strengthened composites, particles are comparatively smaller, and are of 0.01-0.1 $\mu$ m in size. Here the strengthening occurs at atomic/molecular level i.e. mechanism of strengthening is similar to that for precipitation hardening in metals where matrix bears the major portion of an applied load, while dispersoids hinder/impede the motion of

<b>International Association Of Certified Practicing Engineers</b>	<b>ENGINEERING MATERIALS AND THEIR STRENGTH</b>	Page 81 of 151
		Rev: 02
		Jan 2015
<b>CPE LEVEL I TRAINING MODULE</b>		

dislocations. Examples: thoria (ThO<sub>2</sub>) dispersed Ni-alloys (TD Ni-alloys) with high temperature strength; SAP (sintered aluminium powder) – where aluminium matrix is dispersed with extremely small flakes of alumina (Al<sub>2</sub>O<sub>3</sub>)<sup>[18]</sup>.

## ii. Fiber-reinforced composites

Most fiber-reinforced composites provide improved strength and other mechanical properties and strength-to-weight ratio by incorporating strong, stiff but brittle fibers into a softer, more ductile matrix. The matrix material acts as a medium to transfer the load to the fibers, which carry most off the applied load. The matrix also provides protection to fibers from external loads and atmosphere.

These composites are classified as either continuous or discontinuous. Generally, the highest strength and stiffness are obtained with continuous reinforcement. Discontinuous fibers are used only when manufacturing economics dictate the use of a process where the fibers must be in this form.

The mechanical properties of fiber-reinforced composites depend not only on the properties of the fiber but also on the degree of which an applied load is transmitted to the fibers by the matrix phase. Length of fibers, their orientation and volume fraction in addition to direction of external load application affects the mechanical properties of these composites.

### a) Influence of fiber length

Some critical length ( $l_c$ ) is necessary for effective strengthening and stiffening of the composite material, which is defined as

$$l_c = \frac{\sigma_f^* d}{2\tau_c} \quad \text{Eq (14)}$$

Where,

$l_c$  = critical length, in (m)

$\sigma_f^*$  = ultimate/tensile strength of the fiber, psi (Pascal / N/m<sup>2</sup>)

$d$  = diameter of the fiber, in (m)

$\tau_c$  = interface bond strength or the shear yield strength of the matrix, psi  
(Pascal / N/m<sup>2</sup>)

<b>International Association Of Certified Practicing Engineers</b>	<b>ENGINEERING MATERIALS AND THEIR STRENGTH</b>	<b>Page 82 of 151</b>
		<b>Rev: 02</b>
	<b>CPE LEVEL I TRAINING MODULE</b>	<b>Jan 2015</b>

Fibers for which  $l \gg l_c$  (normally  $l > 15l_c$ ) are termed continuous; discontinuous or short fibers have lengths shorter than this. For discontinuous fibers of lengths, there are significantly less than  $l_c$ .

### b) Influence of fiber orientation and concentration

With respect to orientation, two extremes possibilities are parallel alignment and random alignment. Continuous fibers are normally aligned, whereas discontinuous fibers are randomly or partially orientated. Two instants of loading are: longitudinal loading and transverse loading. Following figures are illustrations of continuous and discontinuous fibers.

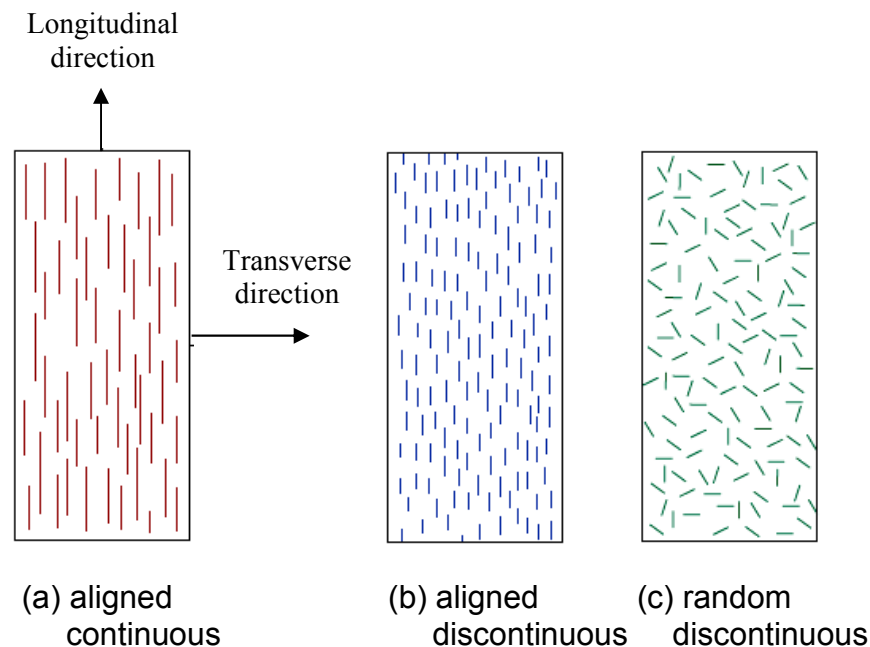

Figure 26 : continuous and discontinuous fibers

<b>International Association Of Certified Practicing Engineers</b>	<b>ENGINEERING MATERIALS AND THEIR STRENGTH</b>	<b>Page 83 of 151</b>
		<b>Rev: 02</b>
	<b>CPE LEVEL I TRAINING MODULE</b>	<b>Jan 2015</b>

- **Continuous fiber composites**

Under longitudinal loading, by assuming that deformation of both matrix and fiber is the same (isostrain condition), rule-of-mixtures results in the following:

$$\sigma_c = \sigma_m \frac{A_m}{A_c} + \sigma_f \frac{A_f}{A_c} \quad \text{Eq (15)}$$

In the composite, if matrix and fiber are all of equal length, area fractions will be equal to volume fractions as defined by

$$\sigma_c = \sigma_m V_m + \sigma_f V_f \quad \text{Eq (16)}$$

In case of transverse loading, it is assumed that both matrix and fiber will experience the equal stress (isostress condition). Then the modulus of the composite is given by

$$E_{ct} = \frac{E_m E_f}{E_f V_m + E_m V_f} = \frac{E_m E_f}{E_f (1 - V_f) + E_m V_f} \quad \text{Eq (17)}$$

Matrix material is softer i.e. fibers strain less and fail before the matrix. And once the fibers have fractured, majority of the load that was borne by fibers is now transferred to the matrix. Based on this criterion the following equation can be developed for longitudinal tensile strength of the composite.

$$\sigma_{cl}^* = \sigma_m' (1 - V_f) + \sigma_f^* V_f \quad \text{Eq (18)}$$

Where,

$\sigma_m'$  = stress in matrix at fiber failure, psi (Pascal / N/m<sup>2</sup>)

$\sigma_f^*$  = fiber tensile strength, psi (Pascal / N/m<sup>2</sup>)

<b>International Association Of Certified Practicing Engineers</b>	<b>ENGINEERING MATERIALS AND THEIR STRENGTH</b>	Page 84 of 151
		Rev: 02
	<b>CPE LEVEL I TRAINING MODULE</b>	Jan 2015

Whereas longitudinal strength is dominated by fiber strength, a variety of factors will have a significant influence on the transverse strength. These include properties of both the fiber and matrix, interface bond strength, and the presence of voids.

- **Discontinuous and aligned fiber composites**

Even though reinforcement efficiency is lower for discontinuous fiber composites than continuous fiber composites, discontinuous and aligned fiber composites are commercially gaining an important place. The longitudinal strength of these composites is given by

When  $l > l_c$ , longitudinal strength becomes,

$$\sigma_{cd}^* = \sigma_f^* V_f \left(1 - \frac{l_c}{2l}\right) + \sigma_m' (1 - V_f) \quad \text{Eq (19)}$$

When  $l < l_c$ , longitudinal strength becomes,

$$\sigma_{cd}^* = \frac{l\tau_c}{d} V_f + \sigma_m' (1 - V_f) \quad \text{Eq (20)}$$

Where,

$\tau_c$  = smaller of either the fiber-matrix bond strength or the matrix shear yield strength, psi (Pascal / N/m<sup>2</sup>)

- **Discontinuous and randomly oriented fiber composites**

Reinforcement efficiency of these fiber composites is difficult to calculate, and is usually characterized by a parameter known as fiber efficiency parameter, K. K depends on  $V_f$  and the  $E_f/E_m$  ratio. If rule-of-mixtures can be applied, elastic modulus of these composites is given by

$$E_{cl} = K(E_m V_m + E_f V_f) \quad \text{Eq (21)}$$

The efficiency of fiber reinforcement, K for several situations can be presented in Table 22.

<b>International Association Of Certified Practicing Engineers</b>	<b>ENGINEERING MATERIALS AND THEIR STRENGTH</b>	Page 85 of 151
		Rev: 02
		Jan 2015
<b>CPE LEVEL I TRAINING MODULE</b>		

Table 22 : efficiency of fiber reinforcement<sup>[7]</sup>

Fiber orientation	Stress direction	Reinforcement efficiency
All fibers parallel	Parallel to fibers	1
	Perpendicular to fibers	0
Fibers randomly and uniformly distributed within a specific plane	Any direction in the plane of the fibers	3/8
Fibers randomly and uniformly distributed within three dimensions in space	Any direction	1/5

### c) Fibers

The most common reinforcement in polymer composites are fibers. These properties are usually exhibited by materials that relatively light elements form thermally stable covalent bonds such as Be, Mg, B, Al, C, Si, Ti. However, many of these materials are quite brittle in bulk form.

Carbons and Silicon are the most important materials that commercially available for high-performance fibers. The fibers could be exhibited to at least three following broad groups of materials, there are Carbon, Organic resins, and inorganic compounds. Each class of fibers is offered an unique characteristic due to a different combination of properties. The various fiber classes established different combinations of mechanical properties, physiochemical properties, electromagnetic properties, and economic characteristics.

#### 1. Carbon Fibers

Carbon fibers are made by the pyrolytic degradation of a fibrous organic precursor. A good fiber precursor has characteristics such as : (1) The chemical structure favors the formation of aligned graphitic carbon structure during pyrolysis process, (2) Obtained a high carbon fiber yield, (3) Well maintained of fiber integrity during pyrolysis, (4) Strong enough to be handled during all phases or pyrolysis process, (5) Cheap and easy in availability of the resources.

#### 2. Organic Fibers

The measured tensile strength and modulus of most natural and synthetic fibers are typically less than 1 and 10GPa. A number of polymeric fibers are now

<b>International Association Of Certified Practicing Engineers</b>	<b>ENGINEERING MATERIALS AND THEIR STRENGTH</b>	Page 86 of 151
		Rev: 02
		Jan 2015
<b>CPE LEVEL I TRAINING MODULE</b>		

commercially available. As compared to other textile fibers, these high-strength, high modulus materials all exhibit a high degree of molecular orientation and chain alignment. High performance organic fibers of this class that have been commercialized to date including : p-aramids, ultrahigh molecular mass polyolefins, and some of polyesters classes.

### 3. Inorganic Fibers

Generally, inorganic fibers have a higher density than the two others. These materials are of interest in the preparation of advanced composite materials because of their stability at high temperature and their compatibility with metal and ceramic matrices, which are also inorganic materials. In addition, any listing of reinforcing fibers for advanced composite applications should include glass fibers due to the lower cost consumption and economic factor as the primary fibrous reinforcing material used by the plastics industry.

#### d) Matrix Materials

The matrix of advanced composite is the continuous phase that binds the fibers together so that they can act in concert. The major characteristics required of a matrix material are that could be :

- Chemically compatible with reinforcing fibers
- Compatible with common manufacturing methods used to fabricate the composites
- Environmentally stable under conditions of use of the advanced composite component

The matrix material is the primary influence on mechanical properties of interlaminar shear strength and compression and flexural strength, especially at high temperature. The matrix also dictates the processibility of the composite, and its environmental resistance. There is no single ideal matrix material that had been existed which satisfied several of requirements imposed by different applications. Hence, advanced composites have been prepared with a diversity of matrix materials, which involving organic polymers, carbon, metals, and ceramics.

Polymeric materials historically have been the predominant matrix materials used in advanced composites. Such as high performance fiber reinforced epoxy resins, many other high performance fibers are now combined with many other thermosetting and thermoplastic resins.

<b>International Association Of Certified Practicing Engineers</b>	<b>ENGINEERING MATERIALS AND THEIR STRENGTH</b>	Page 87 of 151
		Rev: 02
		Jan 2015
<b>CPE LEVEL I TRAINING MODULE</b>		

#### 1. Thermosetting Resins

Thermosets are those resins which in the presence of catalyst, heat, radiation, and/or pressure undergo an irreversible chemical reaction, or cure. Prior to cure, thermosets may be liquid or made to flow under pressure to any desired form. Epoxies are the most commonly matrix materials that used in advanced composite materials. The reason is because the good balance of properties achieved with relative ease of handling and processing. Most of the chemical epoxies are based on bisphenol A. Epoxies can be cured either by ionic copolymerization of the epoxy groups or by reaction with suitable polyfunctional curing agents like amines, anhydrides, phenols, acids or dicyandiamide compound.

#### 2. Thermoplastic Resins

Thermoplastics are materials which are normally solidified at ambient temperature, which could be melted or soften when heated to a sufficiently temperature, and which could be become solid again as it reversed to the initial temperature (being cooled). Thermoplastic resins is usually easier and less expensive to fabricate a complex part other than a thermosetting resin. The resins lend themselves to rapid processing and to the formation of complex parts by processes such as injection, molding, extrusion, and thermoforming. Thermoplastics are generally more ductile and tougher than the thermoset resins. On the other hand, many applications of thermoplastic resins such as polyolefins, vinyls, polyamides, polyacrylics, polyesters than commonly implied.

#### e) Processing of fiber-reinforced composites

Several composite processing techniques have been developed that provide a uniform fiber distribution and a high degree of alignment. With pultrusion, components of continuous length and constant cross section are formed as resin-impregnated fiber tows are pulled through a die. Composites utilized for many structural applications are commonly prepared using a lay-up operation (either hand or automated), wherein prepreg tape plies are laid down on a tooled surface and are subsequently fully cured by the simultaneous application of heat and pressure. Some hollow structures may be fabricated using automated filament winding procedures, whereby resin-coated strands or tows or prepreg tape are continuously wound onto a mandrel, followed by a curing operation. The techniques can be shown in figure 27.

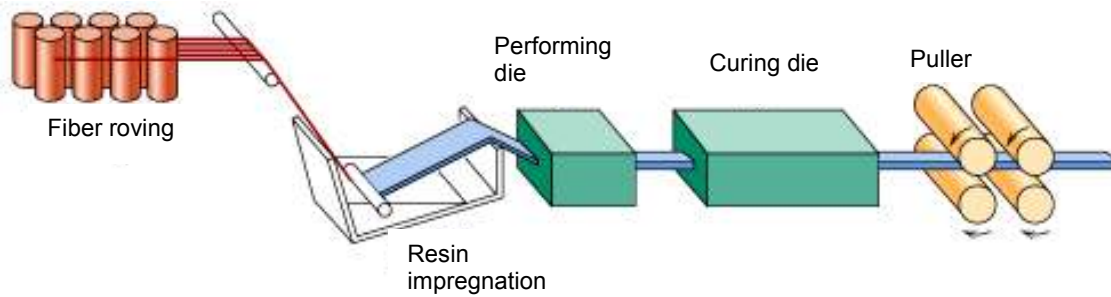

a. the pultrusion process

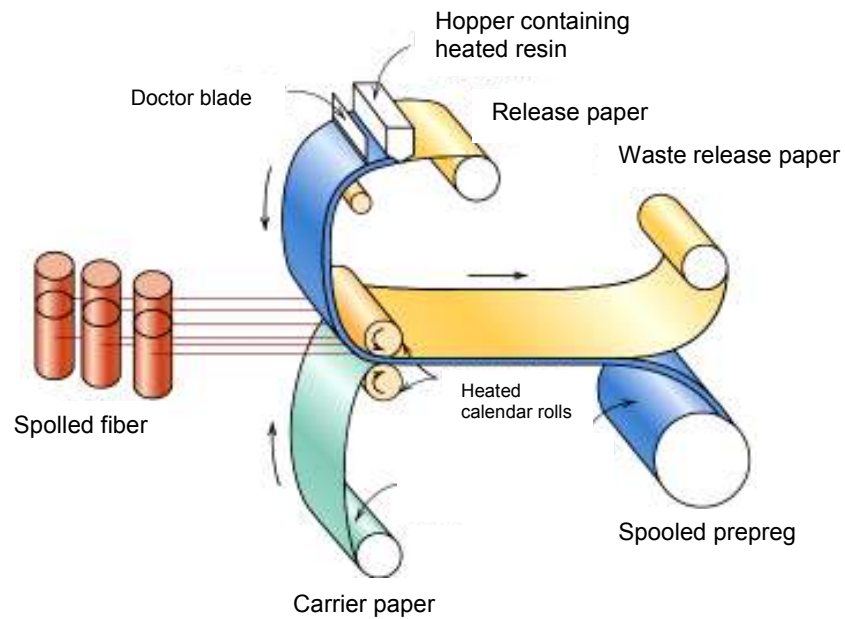

b. the prepreg production process

Figure 27 : pultrusion and prepreg production process

<b>International Association Of Certified Practicing Engineers</b>	<b>ENGINEERING MATERIALS AND THEIR STRENGTH</b>	Page 89 of 151
		Rev: 02
	<b>CPE LEVEL I TRAINING MODULE</b>	Jan 2015

### iii. **Structural composites**

These are special class of composites, usually consists of both homogeneous and composite materials. Properties of these composites depend not only on the properties of the constituents but also on geometrical design of various structural elements. Two classes of these composites widely used are: laminar composites and sandwich structures.

#### - **Laminar composites**

There are composed of two-dimensional sheets/layers that have a preferred strength direction. These layers are stacked and cemented together according to the requirement. Materials used in their fabrication include: metal sheets, cotton, paper, woven glass fibers embedded in plastic matrix, etc. Examples: thin coatings, thicker protective coatings, claddings, bimetals, laminates. Many laminar composites are designed to increase corrosion resistance while retaining low cost, high strength or light weight. The stacking of successive oriented, fiber-reinforced layers for a laminar composite can be illustrated in figure 28.

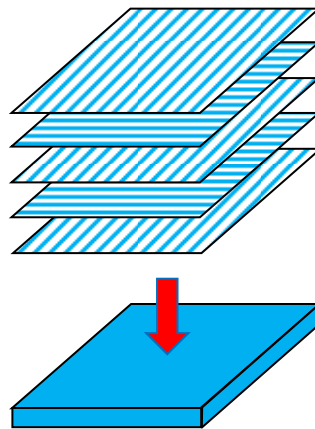

Figure 28 : laminar composite

#### - **Sandwich structures**

These consist of thin layers of a facing material joined to a light weight filler material. Neither the filler material nor the facing material is strong or rigid, but the composite possesses both properties. Example: corrugated cardboard. The faces bear most of

<b>International Association Of Certified Practicing Engineers</b>	<b>ENGINEERING MATERIALS AND THEIR STRENGTH</b>	<b>Page 90 of 151</b>
		<b>Rev: 02</b>
	<b>CPE LEVEL I TRAINING MODULE</b>	<b>Jan 2015</b>

the in-plane loading and also any transverse bending stresses. Typical face materials include Al-alloys, fiber-reinforced plastics, titanium, steel and plywood. The core serves two functions – it separates the faces and resists deformations perpendicular to the face plane; provides a certain degree of shear rigidity along planes that are perpendicular to the faces. Typical materials for core are: foamed polymers, synthetic rubbers, inorganic cements, balsa wood. Sandwich structures are found in many applications like roofs, floors, walls of buildings, and in aircraft for wings, fuselage and tailplane skins. Sandwich structure can be illustrated in figure 29.

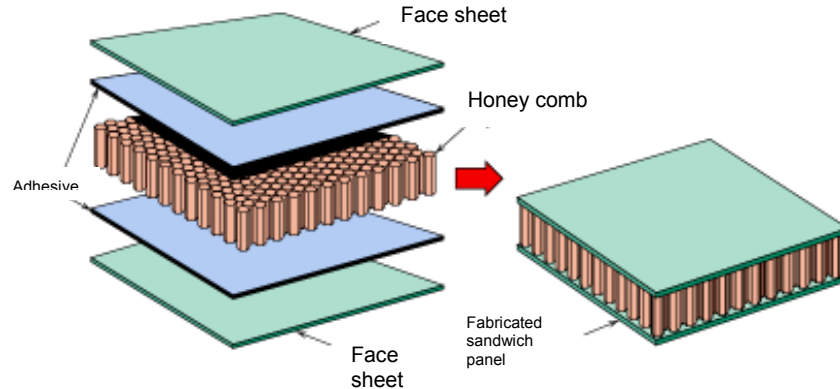

Figure 29 : sandwich structure

#### - **Properties of Composite Structures**

A unique feature of composite materials is the directional dependence of the various properties. This feature is intuitively clear for a unidirectional lamina. This directional dependence of the properties introduces the opportunity to further tailor the material specific applications. Figure 30 represents the common method of controlling fiber directions. By this manual lay-up procedure, sheets of continuous fiber prepregs can be stacked in a variety of prescribed orientations. Table 23 represents an example of the effects of fiber orientation, developed through different stacking sequences.

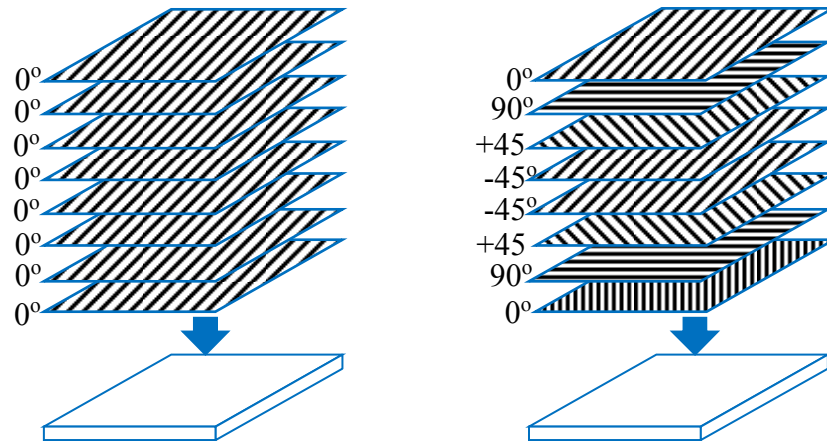

Figure 30 : configuration of composite lay-up (left : unidirectional, right :crossplied quasi-isotropic)

Table 23 : effect of fiber orientation to mechanical properties

Material	Fiber lay-up	Density, g/cm <sup>3</sup>	Elastic Modulli, Gpa			Ultimate Strength, MPa		
			Longi tudinal	Trans verse	Shear	Longi Tudinal	Trans verse	Shear
A type graphite/ epoxy	Unidirectional (0°)	1.57	138	6.9	4.5	1517	41	97
	Crossply (0°, 90°)	1.57	74	74	4.5	838	838	97
	Crossply (± 45°)	1.57	17.2	17.2	31.0	138	138	345
	Isotropic (0°, 90°, ± 45°)	1.57	48	48	17.8	604	604	221
UHM Type graphite/ Epoxy	Unidirectional (0°)	1.68	303	6.9	6.6	758	28	48
	Crossply (0°, 90°)	1.68	159	159	6.6	402	402	48
	Crossply (± 45°)	1.68	20.7	20.7	79.3	96.5	96.5	207
	Isotropic (0°, 90°, ± 45°)	1.68	103	103	42.8	242	242	128

<b>International Association Of Certified Practicing Engineers</b>	<b>ENGINEERING MATERIALS AND THEIR STRENGTH</b>	Page 92 of 151
		Rev: 02
		Jan 2015
<b>CPE LEVEL I TRAINING MODULE</b>		

Continued from Table 23

Material	Fiber lay-up	Density, g/cm <sup>3</sup>	Elastic Modulli, Gpa			Ultimate Strength, MPa		
			Longi tudinal	Trans verse	Shear	Longi Tudinal	Trans verse	Shear
Kevlar 49/ epoxy	Unidirectional (0°)	1.38						
	Crossply (0°, 90°)	1.38						
	Crossply (± 45°)	1.38	7.6	7.6	20.7	207 517 (tens)	207	221
	Isotropic (0°, 90°, ± 45°) 181 fabric (warp. 50v/e)	1.33	31	31	2.0	172 (comp)	17 (tens) 172 (comp)	110
S-glass/ Epoxy	Unidirectional (0°)	1.88	48	6.9	3.4	1730	40	10
	Crossply (0°, 90°)	1.88	31	31		980	900	
	Crossply (± 45°)	1.88	16	16		170	170	
	Isotropic (0°, 90°, ± 45°)	1.88	25	25		730	730	

### c. Process of composites

Composites could be achieved from thermomechanical process or chemical reactions. The key characteristics sought in an incorporated substance, which are in turn conferred on the composite, are above all elastic rigidity, tensile and fatigue strength, and hardness as well as appropriate electrical and magnetic properties.

As in general, the way to produce composite materials is by thermomechanical process. An interesting alternative to thermomechanical mixing is the possibility of using a phase separation process within a homogenous starting to create the desired heterogeneity. This processes lend themselves to eutectic crystallization from a melt, eutectic decomposition of solid solutions or phase separation within a supersaturated solid solution. The method is particularly an a elegant one and affords an opportunity to produce a fine geometric distribution of the phase components. Nonetheless, like any other process, it has a

<b>International Association Of Certified Practicing Engineers</b>	<b>ENGINEERING MATERIALS AND THEIR STRENGTH</b>	<b>Page 93 of 151</b>
		<b>Rev: 02</b>
	<b>CPE LEVEL I TRAINING MODULE</b>	<b>Jan 2015</b>

disadvantage such as high limitation of an amount number from its component to build a desirable properties, and should have a strong control of the reaction.

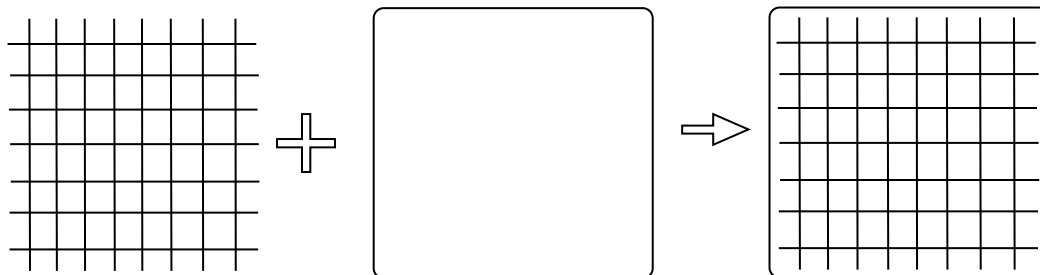

Figure 31 : thermomechanical process

A material prepared in the latter way through controlled solidification of a eutectic mixture is referred to as a directionally solidified eutectic, or commonly called 'DSE'. The method of phase separation is best suited to the manufacture of small items that are subject to rigid demands, where cost plays a minor role. Figure 31 and Figure 32 show the schematic process of thermomechanical mixing process and In-situ preparation by 'phase-separation'.

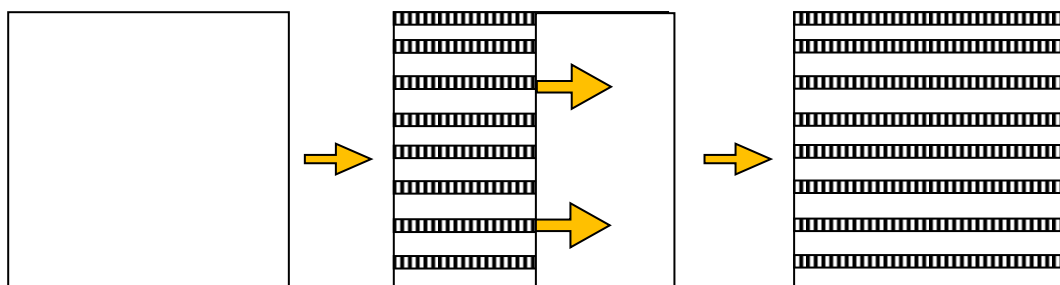

Figure 32 : In-situ preparation

<b>International Association Of Certified Practicing Engineers</b>	<b>ENGINEERING MATERIALS AND THEIR STRENGTH</b>	<b>Page 94 of 151</b>
		<b>Rev: 02</b>
		<b>Jan 2015</b>
<b>CPE LEVEL I TRAINING MODULE</b>		

#### **d. Ceramic – Metal Composites**

One example of composites that is commonly used, includes ceramic – metal composite. Ceramic – metal composites could be described as the heterogenous combination of one or more ceramic phases with one or more metals or alloys. Systems with very small amounts of metal or ceramic are usually not considered as composite materials. The distribution of phases in ceramic – metal composites is typically at fine structural level (microscopic). The ceramic and metal phases are mixed physically often with a binder, formed and fired at elevated temperature.

Two classes of materials include: (1) Cermets and (2) Metal Matrix Composites (MMC). Cermet as in general is understood to consist of continuous or partially continuous metal phases with ceramic particles having similar size in all dimensions. On the other hand, the metal matrix composites may be distinguished by the high aspect ratio of the ceramic constituent, the metals are surround long continuous or chopped fibers or elongated single – crystal whiskers of ceramic composition.

- **Cermets and Cemented Carbides**

Within the cermet subcategory of ceramic – metal composites, there is a nomenclature difficulty. Cermets and cemented carbides derive their usefulness from the combination of compressive strength, hardness, and thermal resistance provided by the ceramic with ductility, lubricity, and adhesion provided by metal. The cermets and cemented carbides are used for their strength, hardness and abrasion resistance, particularly at elevated temperatures such as rock cutting, turbine parts, flame nozzles. Cermets are generally prepared by mixing carbide and/or oxide powder with metal powder in the presence of a binder. An alternative method for preparing cermets involving slip casting, liquid – metal infiltration, or hot pressing or parts.

- **Metal Matrix Composites**

The advantages that metal matrix composites offer over conventional metals include : (1) the anisotropic character of the composite in the efficient design and fabrication of components, (2) manufacturing an engineered material with a specific set of strength and toughness requirements, and (3) increasing the strength, modulus, creep resistance, and oxidation resistance of common engineering alloys. In order to other composite matrices, the greatest potential advantages of the metal matrix are its resistance to severe environments, toughness and strength at high temperatures.

<b>International Association Of Certified Practicing Engineers</b>	<b>ENGINEERING MATERIALS AND THEIR STRENGTH</b>  <b>CPE LEVEL I TRAINING MODULE</b>	Page 95 of 151
		Rev: 02
		Jan 2015

**i. Ceramic – Metal Systems (Cermet)**

Ceramics and Metals could be joined at the solid state or it could be with one component deposited as a liquid or vapor. Bonding may occur by surface or interfacial interaction. Dependent on the chemical nature of the materials, solution, and redox reactions may proceed, thus promoting adherence. Another key factor that could affect the bond at a ceramic-to-metal interface is stress between the ceramic and metal.

As the material cools from fabrication at elevated temperature, differences in thermal expansion can give rise to residual stresses. Temperature changes during the process could be also resulting a similar effect. Forces at the ceramic – metal interface can exceed the strength of the bond between materials, preventing a macroscopic join, causing delamination of a coating, or affecting composite properties.

Thermal expansion of a metal as in general is greater than ceramic and glass material (Figure 33). The higher shrinkage of a metal in a flat sheet causes net compressive stresses in the ceramic tensile stresses in the metal. The condition gives an advantage to ceramics materials, because normally ceramics is far greater compressive than tensile strength. Nonetheless, if the stress set too high, failure could occur in the interface or on the other material.

There is an amount of several approaches that could be used to limit the thermally induced residual stresses. A common alloy in glass sealing (as referred at ASTM15) is set of iron, 28 – 29% wt nickel, and 17 – 18% wt cobalt alloys. The trade name of this kind of type limitation often called '*Kovar*'. In additional, '*Housekeeper seal*' is a very thin piece, slight size, low yield strength, and ductility of metal that limit the induced stresses. One approaches design to predict the magnitude of residual stresses that result from thermal expansion differences cited as a '*Compression Seal*'. The ceramic is placed in compression and the metal is placed in tension by this system.

<b>International Association Of Certified Practicing Engineers</b>	<b>ENGINEERING MATERIALS AND THEIR STRENGTH</b>	<b>Page 96 of 151</b>
	<b>CPE LEVEL I TRAINING MODULE</b>	
	<b>Rev: 02</b>  <b>Jan 2015</b>	

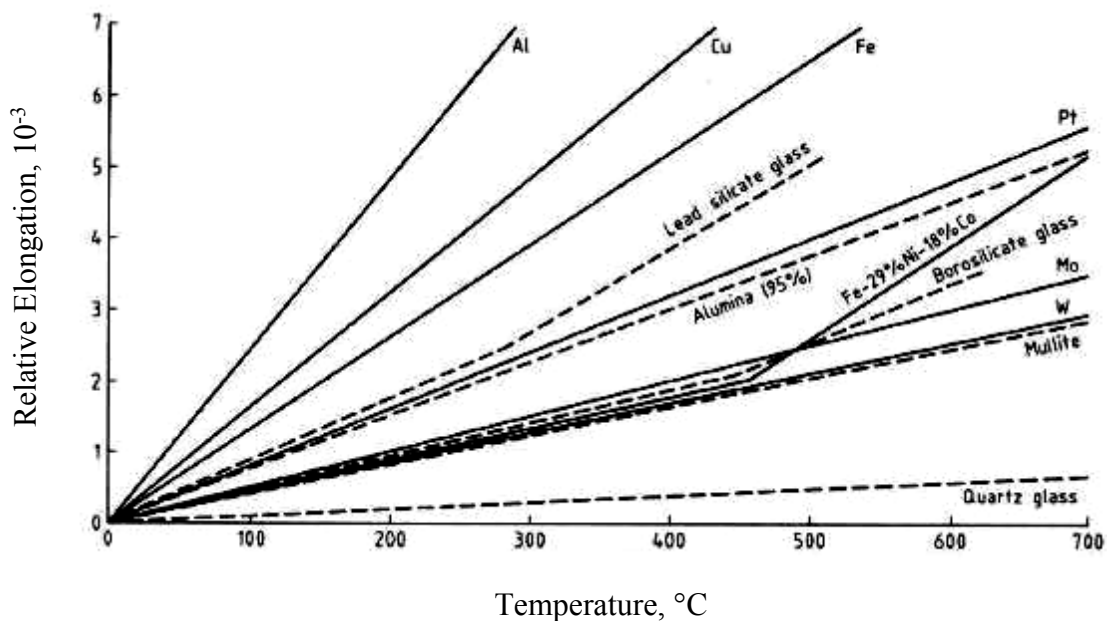

Figure 33 : thermal expansion of typical ceramics

Along with the temperature's effect, there is also the difference in the elastic modulus of stiffness of the ceramic and the metal components of a system of composite that achieved in material or interfacial failure under applied and residual stresses. Figure 34 represents the elastic modulus effect of ceramic material that concluded generally lower stiffness than a metals material had. It is shown by the slope position of both curve.

Elastic modulus effect could lead to failure of a ceramic – metal join or coating. For composite material, the situation could be more sophisticated as sharing of load may be desired. However, when a failure crack propagates, failure at the ceramic – metal interface may be desirable so that crack is diverted and fracture energy is expanded in the process. Such considerations may be complex, involving the properties of ceramic and metal, chemical interaction zones between materials and microstructural and geometrical factors.

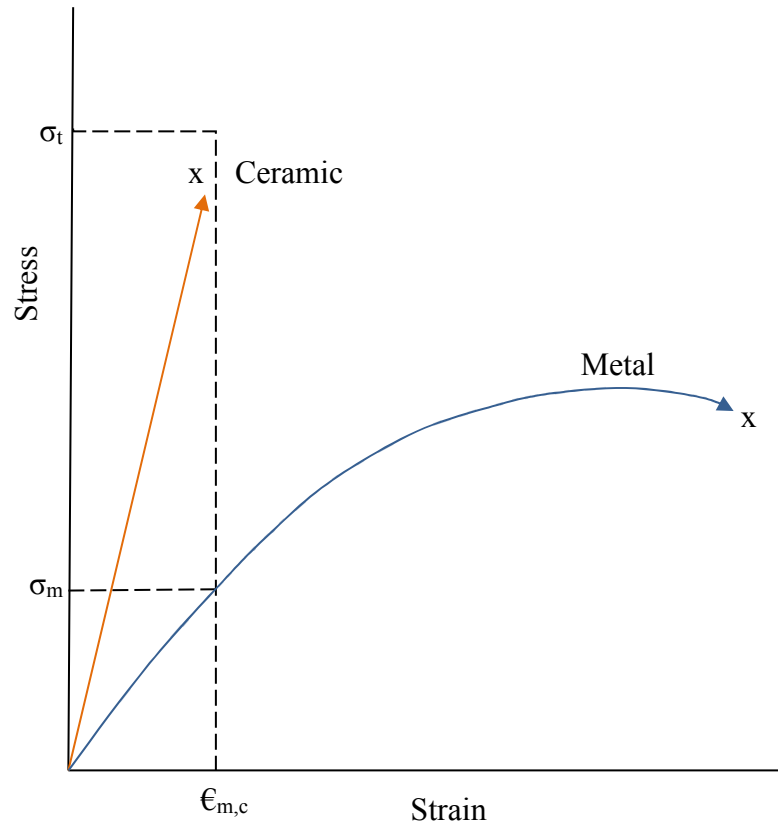

Figure 34 : elastic modulus effect

## II. Strength of Materials

### A. Stress and Strain – Axial Loading

Deformations are changes in form produced by external forces or loads that act on nonrigid bodies. As example, bar is a straight structural member having the same cross section throughout its length, and an axial force is a load directed along the axis of the member, resulting in either tension or compression in the bar. A straight bar will change in length when loaded axially, becoming longer when in tension and shorter when in compression. It can be illustrated in figure 35<sup>[3]</sup>.

<b>International Association Of Certified Practicing Engineers</b>	<b>ENGINEERING MATERIALS AND THEIR STRENGTH</b>	<b>Page 98 of 151</b>
	<b>CPE LEVEL I TRAINING MODULE</b>	
	<b>Jan 2015</b>	

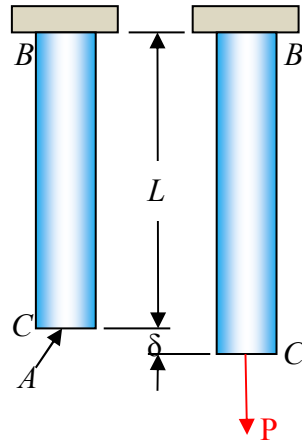

Figure 35 : deformation of axially-loaded bar

Uniform distribution of stresses is an assumption that is frequently considered in the design process<sup>[15]</sup>. Stress could be described as an amount of force load to a certain area of material. The uniformly distributed normal stress is

$$\sigma = \frac{P}{A} \quad \text{Eq (22)}$$

Where,

- $\sigma$  = stress, psi (Pascal / N/m<sup>2</sup>)
- $P$  = loaded force, lb (N)
- $A$  = area of cross section, in<sup>2</sup> (m<sup>2</sup>)

If a tensile load is applied to a straight bar, it becomes longer. The amount of elongation is called the total strain. The elongation per unit length of the bar  $E$  is called strain. The expression for strain is given by

$$\epsilon = \frac{\delta}{L} \quad \text{Eq (23)}$$

Where,

- $\epsilon$  = strain, in/in (m/m)
- $\delta$  = elongation or extension of material, in (m)
- $L$  = original material length, in (m)

<b>International Association Of Certified Practicing Engineers</b>	<b>ENGINEERING MATERIALS AND THEIR STRENGTH</b>	Page 99 of 151
		Rev: 02
		Jan 2015
<b>CPE LEVEL I TRAINING MODULE</b>		

Elongation has considerable engineering significance because it indicates ductility. The ductility of a material in tension can be characterized by its elongation and by the reduction in area at the cross section where fracture occurs. The percent elongation is defined as

$$\%elongation = \frac{L_1 - L_0}{L_0} \times 100 \quad \text{Eq (24)}$$

Where,

- $L_0$  = original length, in (m)
- $L_1$  = final length at fracture, in (m)

Another measure of ductility which is sometimes used is the percent reduction in area. The percent reduction in area measures the amount of necking that occurs and is defined as follows<sup>[12]</sup>.

$$\%reduction = \frac{A_1 - A_0}{A_0} \times 100 \quad \text{Eq (25)}$$

Where,

- $A_0$  = original cross-sectional area, in<sup>2</sup> (m<sup>2</sup>)
- $A_1$  = final area at the fracture section, in<sup>2</sup> (m<sup>2</sup>)

#### **a. Hooke's law and poisson's ratio**

Many structural materials, including most metals, wood, plastics, and ceramics, behave both elastically and linearly when first loaded. It exhibits a linear relationship between stress and strain, this relation is known as Hooke's law. Hooke's law is defined as follow.

$$\sigma = E \epsilon \quad \text{Eq (26)}$$

Where,

- $E$  = a constant of proportionality known as modulus of elasticity or Young's Modulus, psi (Pascal / N/m<sup>2</sup>)

<b>International Association Of Certified Practicing Engineers</b>	<b>ENGINEERING MATERIALS AND THEIR STRENGTH</b>	<b>Page 100 of 151</b>
		<b>Rev: 02</b>
		<b>Jan 2015</b>
<b>CPE LEVEL I TRAINING MODULE</b>		

The modulus of elasticity is the ratio of stress to strain. The modulus of elasticity could be defined at least by three elastic moduli : Tensile Modulus of Young's Modulus (E), Shear Modulus (G), and Bulk Modulus (K) or also often are called Comprehensive Modulus.

$$E = \frac{\sigma}{\epsilon} \quad \text{Eq (27)}$$

$$G = \frac{\tau}{\gamma} \quad \text{Eq (28)}$$

$$K = -\frac{P}{\left(\frac{\Delta V}{V_o}\right)} \quad \text{Eq (29)}$$

Each values of them could inversely proportional to the corresponding compliances (inverse of stiffness) for static deformations that are given as follow.

$$D = 1/E \quad \text{Eq (30)}$$

$$J = 1/G \quad \text{Eq (31)}$$

$$B = 1/K \quad \text{Eq (32)}$$

Substituting normal stress and strain equations to Eq (26), then the total deformation  $\delta$  of a bar loaded in axial tension or compression can be defined by<sup>[15]</sup>

$$\delta = \frac{Pl}{AE} \quad \text{Eq (33)}$$

Poisson's ratio is the absolute value of the ratio of transverse or lateral strain to axial strain resulting from a uniformly applied axial stress below the proportional limit of the material<sup>[13]</sup>. Poisson's ratio is also related to comprehensive modulus, by the following (for isotropic solids, those for which properties are independent of direction). Poisson ratio can be represented as follow.

$$\nu = -\frac{\epsilon_{lateral}}{\epsilon_{axial}} = \frac{(3K - 2G)}{(6K + 2G)} \quad \text{Eq (34)}$$

<b>International Association Of Certified Practicing Engineers</b>	<b>ENGINEERING MATERIALS AND THEIR STRENGTH</b>	<b>Page 101 of 151</b>
		<b>Rev: 02</b>
	<b>CPE LEVEL I TRAINING MODULE</b>	<b>Jan 2015</b>

And one of moduli elastic relations can be expressed by the following equation<sup>[3]</sup>.

$$E = 2G(1 + \nu) \quad \text{Eq (35)}$$

Where,

- D = tensile compliance,  $\text{psi}^{-1}$  (Pascal /  $\text{N/m}^2$ )<sup>-1</sup>
- J = shear compliance,  $\text{psi}^{-1}$  (Pascal /  $\text{N/m}^2$ )<sup>-1</sup>
- B = bulk compliance,  $\text{psi}^{-1}$  (Pascal /  $\text{N/m}^2$ )<sup>-1</sup>
- $\nu$  = Poisson Ratio
- K = Bulk Modulus, psi (Pascal /  $\text{N/m}^2$ )
- G = Shear Modulus, psi (Pascal /  $\text{N/m}^2$ )
- $\epsilon_{\text{lateral}}$  = lateral strain (negative for axial tension (stretching), positive for axial compression), in/in (m/m)
- $\epsilon_{\text{axial}}$  = axial strain (positive for axial tension, negative for axial compression) , in/in (m/m)
- $\tau$  = shear stress, psi (Pascal /  $\text{N/m}^2$ )
- $\gamma$  = shear strain, in/in (m/m)

## B. Torsion

Torsion could be defined as the twisting of an object due to an applied torque. Torsional loads on circular shafts that is interested in stresses and strains of circular shafts subjected to twisting couples or torques. Turbine exerts torque  $T$  on the shaft. Then, shaft transmits the torque to the generator. Generator creates an equal and opposite torque  $T'$ . That is illustrated in figure 36.

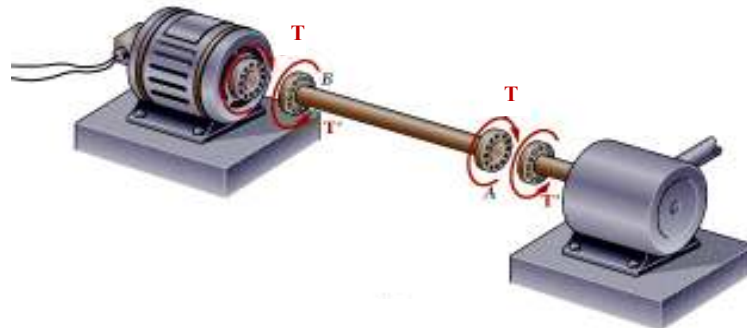

Figure 36 : transmission shaft

<b>International Association Of Certified Practicing Engineers</b>	<b>ENGINEERING MATERIALS AND THEIR STRENGTH</b>	<b>Page 102 of 151</b>
		<b>Rev: 02</b>
	<b>CPE LEVEL I TRAINING MODULE</b>	<b>Jan 2015</b>

### a. Net Torque Due to Internal Stresses

Net of the internal shearing stresses is an internal torque, equal and opposite to the applied torque. Shaft subject to torques can be described in figure 37.

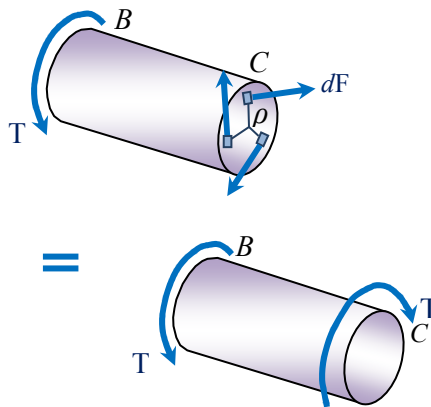

Figure 37 : shaft to torque

The sum of the moments of the shearing forces  $dF$  about the axis of the shaft is equal in magnitude to the torque  $T$ . It is expressed as

$$T = \int \rho dF = \int \rho(\tau dA) \quad \text{Eq (36)}$$

Where,

- $\rho$  = the perpendicular distance from the force to the axis of the shaft, in (m)
- $F$  = force, lbf (N)
- $A$  = element of area, in<sup>2</sup> (m<sup>2</sup>)

Although the net torque due to the shearing stresses is known, the distribution of the stresses is not. Distribution of shearing stresses is statically indeterminate – must consider shaft deformations. Unlike the normal stress due to axial loads, the distribution of shearing stresses due to torsional loads can not be assumed uniform.

### b. Deformations in a Circular Shaft

If a torque  $T$  is applied to the other end, the shaft will twist, with its free end rotating through an angle  $\phi$  called the angle of twist. The angle of twist of the shaft is proportional to the applied torque and to the shaft length. It can be shown in figure 38.

<b>International Association Of Certified Practicing Engineers</b>	<b>ENGINEERING MATERIALS AND THEIR STRENGTH</b>	<b>Page 103 of 151</b>
		<b>Rev: 02</b>
	<b>CPE LEVEL I TRAINING MODULE</b>	<b>Jan 2015</b>

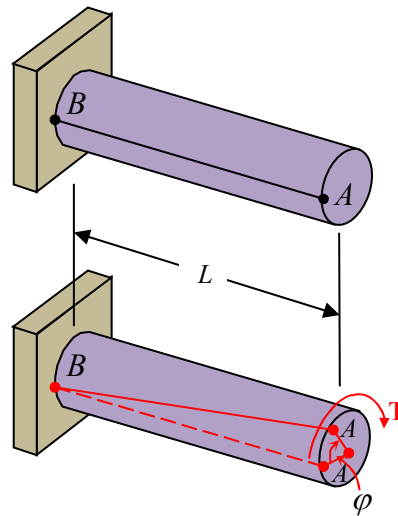

Figure 38 : shaft with fixed support

When subjected to torsion, every cross-section of a circular shaft remains plane and undistorted. Cross-sections for hollow and solid circular shafts remain plain and undistorted because a circular shaft is axisymmetric. Whereas, cross-sections of noncircular (non-axisymmetric) shafts are distorted when subjected to torsion. They can be compared as shown as follow.



Figure 39 : comparison of deformations in circular and square shafts

### c. Shearing Strain

Consider an interior section of the shaft. As a torsional load is applied, an element on the interior cylinder deforms into a rhombus. Since the ends of the element remain planar, the shear strain is equal to angle of twist. It is shown in figure 40.

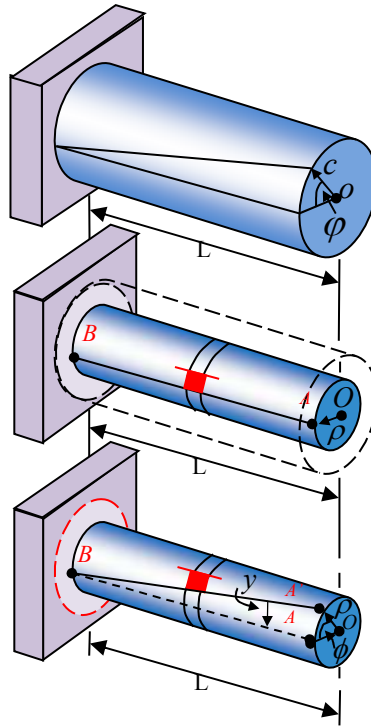

Figure 40 : shearing strain

The equation that represents the figure is

$$\gamma = \frac{\rho\phi}{L} \quad \text{Eq (37)}$$

The shearing strain in a circular shaft varies linearly with the distance from the axis of the shaft. It follows the equation that the shearing strain is maximum on the surface of the shaft, where  $\rho = c$ .

$$\gamma_{\max} = \frac{c\phi}{L} \quad \text{Eq (38)}$$

<b>International Association Of Certified Practicing Engineers</b>	<b>ENGINEERING MATERIALS AND THEIR STRENGTH</b>	<b>Page 105 of 151</b>
		<b>Rev: 02</b>
	<b>CPE LEVEL I TRAINING MODULE</b>	<b>Jan 2015</b>

By eliminating  $\phi$  to the equations, shearing strain becomes,

$$\gamma = \frac{\rho}{c} \gamma_{\max} \quad \text{Eq (39)}$$

#### d. Stresses in the Elastic Range

In fact, the stresses in the shaft will remain below the proportional limit and below the elastic limit as well. Thus, Hooke's law will apply and there will be no permanent deformation. The shearing stress can be obtained by multiplying both members Eq (39) by shear modulus as Eq (28),

$$G\gamma = \frac{\rho}{c} G\gamma_{\max} \quad \text{Eq (40)}$$

Then, replacing  $G\gamma$  by using shear stress in shear modulus equation. Therefore, shearing stress becomes,

$$\tau = \frac{\rho}{c} \tau_{\max} \quad \text{Eq (41)}$$

The shearing stress varies linearly with the radial position in the section. Elastic torsion formulas can be obtained by input shearing stress in Eq (41) to the sum of the moments from the internal stress distribution. Distribution of shearing stress is illustrated in following figure.

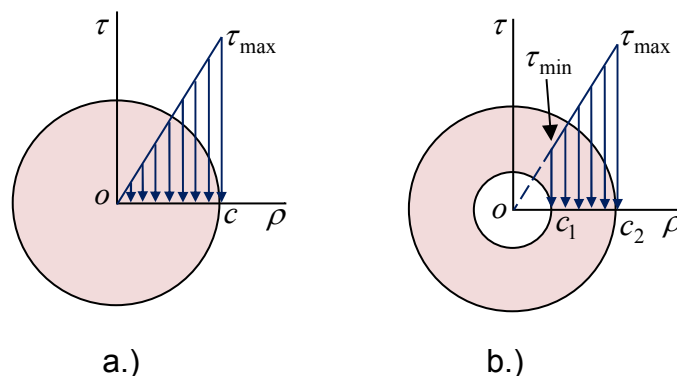

Figure 41 : distribution of shearing stress

<b>International Association Of Certified Practicing Engineers</b>	<b>ENGINEERING MATERIALS AND THEIR STRENGTH</b>	Page 106 of 151
		Rev: 02
	<b>CPE LEVEL I TRAINING MODULE</b>	Jan 2015

Thus, elastic torsion can be defined by

$$T = \int \rho \tau dA = \frac{\tau_{\max}}{c} \int \rho^2 dA = \frac{\tau_{\max}}{c} J \quad \text{Eq (42)}$$

And the shearing stress,

$$\tau_{\max} = \frac{Tc}{J} \quad \text{Eq (43)}$$

$$\tau = \frac{T\rho}{J} \quad \text{Eq (44)}$$

The polar moment of inertia of a circle of radius as figure 41a.) is given as

$$J = \frac{1}{2} \pi c^4 \quad \text{Eq (45)}$$

Whereas, in the case of hollow circular shaft, the polar moment of inertia is

$$J = \frac{1}{2} \pi (c_2^4 - c_1^4) \quad \text{Eq (46)}$$

Where,

- T = torque, lb.in. (N.m)
- c = radius, in (m)
- J = polar moment of inertia, in<sup>4</sup> (m<sup>4</sup>)

#### e. Angle of Twist in the Elastic Range

The maximum shear stress is one of major design constraints in relation to strength of shaft. However, sometime the design may depend on restricting the amount of rotation or twist when the shaft is subjected to a torque. In elastic range, the maximum shearing strain in shear modulus is related with shearing stress in Eq (43) as follow.

$$\gamma_{\max} = \frac{\tau_{\max}}{G} = \frac{Tc}{JG} \quad \text{Eq (47)}$$

Then, the equation is related with Eq (38) for obtaining the angle of twist. Hence, it becomes,

$$\phi = \frac{TL}{JG} \quad \text{Eq (48)}$$

<b>International Association Of Certified Practicing Engineers</b>	<b>ENGINEERING MATERIALS AND THEIR STRENGTH</b>	<b>Page 107 of 151</b>
		<b>Rev: 02</b>
	<b>CPE LEVEL I TRAINING MODULE</b>	<b>Jan 2015</b>

Where,  
 $\phi$  = angle twist, rad

If the torsional loading or shaft cross-section changes along the length, the angle of rotation is found as the sum of segment rotations.

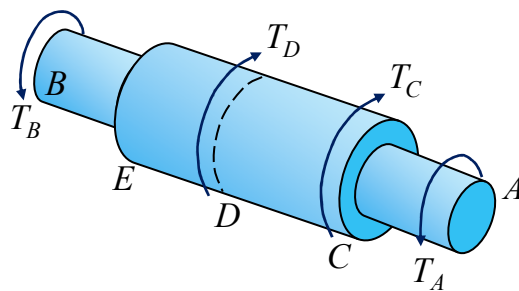

Figure 42 : multiple sections and multiple torques

The angle of rotation of multiple sections becomes<sup>[3]</sup>,

$$\theta = \sum_i \frac{T_i L_i}{J_i G_i} \quad \text{Eq (49)}$$

#### f. Sign Convention of Internal Torque

A sign convention for internal torque and angle of twist of one end with respect to the other end. The right-hand rule is typically used, whereby both the torque and angle will be positive, provided the thumb is directed outward from the shaft when the fingers curl to give the tendency for rotation, as illustrated in Figure 43.

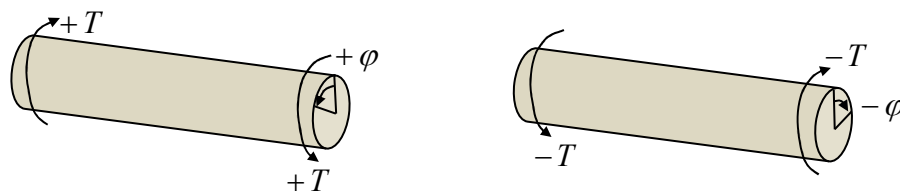

Figure 43 : sign conventions for torque and angle of twist

<b>International Association Of Certified Practicing Engineers</b>	<b>ENGINEERING MATERIALS AND THEIR STRENGTH</b>	<b>Page 108 of 151</b>
		<b>Rev: 02</b>
	<b>CPE LEVEL I TRAINING MODULE</b>	<b>Jan 2015</b>

### g. Power of a Rotating Shaft

The power  $P$  transmitted by a shaft under torque and rotating at angular velocity is<sup>[21]</sup>

In British unit,

$$P = T \cdot \omega = \frac{2\pi NT}{33000} \quad \text{Eq (50)}$$

In SI unit,

$$P = T \cdot \omega = 2\pi fT = \frac{2\pi NT}{60} \quad \text{Eq (51)}$$

Where,

- P = power, hp (watts)
- N = shaft speed, rpm
- T = torque, lb.ft (N.m)
- f = frequency, Hz ( $s^{-1}$ )

### h. Miscellaneous of Torsion

This section provides the formulae for stress and angle of twist for a solid, hollow circular shaft, rectangular bar and a thin tubular section. The hollow shaft size equivalent in strength to a solid shaft is given various ratios of bore outside diameter.

#### 1. Solid circular shaft

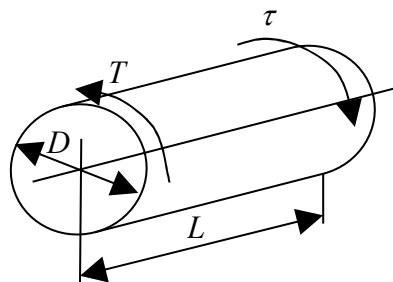

Figure 44 : solid circular shaft

The formulas of solid circular shaft torsions are given as

Maximum shear stress ( $\tau_m$ ) :

$$\tau_m = \frac{16T}{\pi D^3} \quad \text{Eq (52)}$$

<b>International Association Of Certified Practicing Engineers</b>	<b>ENGINEERING MATERIALS AND THEIR STRENGTH</b>	<b>Page 109 of 151</b>
	<b>CPE LEVEL I TRAINING MODULE</b>	<b>Rev: 02</b>
		<b>Jan 2015</b>

Torque capacity (T) :

$$T = \frac{\pi D^3 \tau_m}{16} \quad \text{Eq (53)}$$

Angle of twist ( $\phi$ ) :

$$\phi = \frac{32TL}{\pi GD^4} \text{ rad} \quad \text{Eq (54)}$$

Where,

$\tau_m$  : Maximum shear stress, psi (Pascal / N/m<sup>2</sup>)  
D : Diameter, in (m)

## 2. Hollow circular shaft

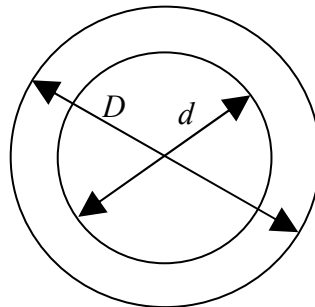

Figure 45 : hollow circular shaft

Hollow circular shaft torsion can be determined by using following equations.

Maximum shear stress ( $\tau_m$ ) :

$$\tau_m = \frac{16TD}{\pi(D^4 - d^4)} \quad \text{Eq (55)}$$

Torque capacity (T) :

$$T = \frac{\pi(D^4 - d^4)}{16D} \tau_m \quad \text{Eq (56)}$$

<b>International Association Of Certified Practicing Engineers</b>	<b>ENGINEERING MATERIALS AND THEIR STRENGTH</b>	<b>Page 110 of 151</b>
		<b>Rev: 02</b>
	<b>CPE LEVEL I TRAINING MODULE</b>	<b>Jan 2015</b>

Angle of twist ( $\phi$ ) :

$$\phi = \frac{32TL}{\pi G(D^4 - d^4)} \text{ rad} \quad \text{Eq (57)}$$

Where,

D : Outer Diameter, in (m)  
d : Inside Diameter, in (m)

### 3. Rectangular section bar

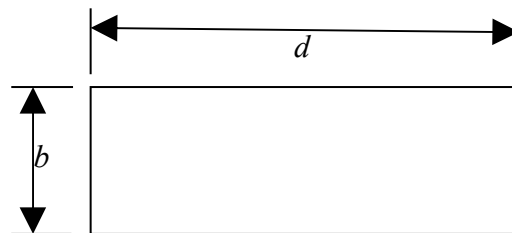

Figure 46 : rectangular bar

The formulas of rectangular bar are given as

If  $d > b$  :

Maximum shear stress ( $\tau_m$ ) :

$$\tau_m = \frac{(1.8b + 3d)T}{b^2 d^2} \text{ (at middle of side d)} \quad \text{Eq (58)}$$

Angle of twist ( $\theta$ ) :

$$\phi = \frac{7TL(b^2 + d^2)}{2Gb^3 d^3} \text{ rad} \quad \text{Eq (59)}$$

<b>International Association Of Certified Practicing Engineers</b>	<b>ENGINEERING MATERIALS AND THEIR STRENGTH</b>	<b>Page 111 of 151</b>
		<b>Rev: 02</b>
	<b>CPE LEVEL I TRAINING MODULE</b>	<b>Jan 2015</b>

#### 4. Thin tubular section

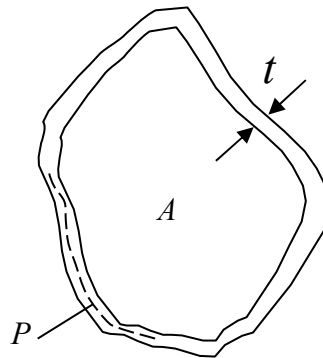

Figure 47 : thin tubular section

Thin tubular section torsion can be determined by using following equations.

Maximum shear stress ( $\tau_m$ ) :

$$\tau_m = \frac{T}{2t \cdot A} \quad \text{Eq (60)}$$

Angle of twist ( $\phi$ ) :

$$\phi = \frac{TpL}{4A^2tG} \text{ rad} \quad \text{Eq (61)}$$

Where,

- t : Thickness, in (m)
- p : Mean perimeter, in (m)
- A : Are enclosed by mean perimeter, in<sup>2</sup> (m<sup>2</sup>)

### C. Shear Forces and Bending Moments

Engineering design involves the correct determination of the sizes of components to withstand the maximum stress due to combination of direct, bending and shear loads. This section provides a limited case of two-dimensional stress, bending and shear loads that practically dealt with, although many cases of three-dimensional stress combination occur.

**a. Types of Beams, Loads, and Reactions**

Beams are usually described by the manner in which they are supported. They are classified into three class. There are simply supported beam or a simple beam which is a beam with a pin support at one end and a roller support at the other; cantilever beam which the beam that is fixed at one end and free at the other; and a beam with an overhang which beam is simply supported at points A and B (that is, it has a pin support at A and a roller support at B) but it also projects beyond the support at B. The overhanging segment BC is similar to a cantilever beam except that the beam axis may rotate at point B. They are illustrated in following figure<sup>[12]</sup>.

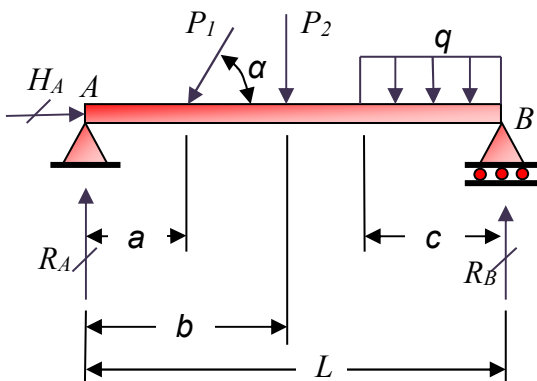

a.) simple beam

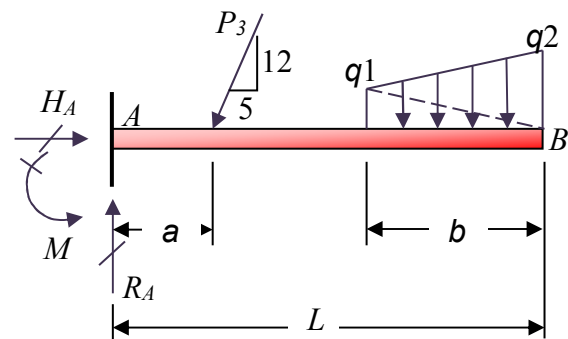

b.) cantilever beam

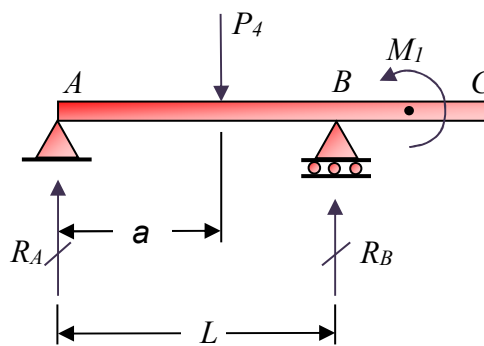

c.) beam with an overhang

Figure 48 : types of beams

<b>International Association Of Certified Practicing Engineers</b>	<b>ENGINEERING MATERIALS AND THEIR STRENGTH</b>	<b>Page 113 of 151</b>
		<b>Rev: 02</b>
	<b>CPE LEVEL I TRAINING MODULE</b>	<b>Jan 2015</b>

Several types of loads can act on beams, such as concentrated loads, distributed loads, and couples. Concentrated loads are idealized from loads applied on a very small area. Distributed loads are spread along the axes of beams. For example, the weight of the beam can be assumed as a distributed force. Couples are moments applied on the beam. They can be illustrated in figure 49<sup>[27]</sup>.

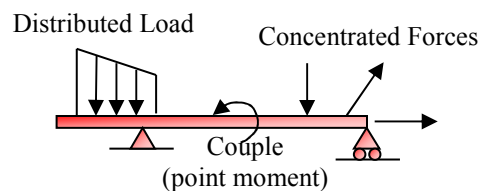

Figure 49 : types of loads

Distributed loads can be split into separate distributed load. This makes finding the total equivalent force easier without doing the actual integration. Following figure is an example that is typically used in construction application.

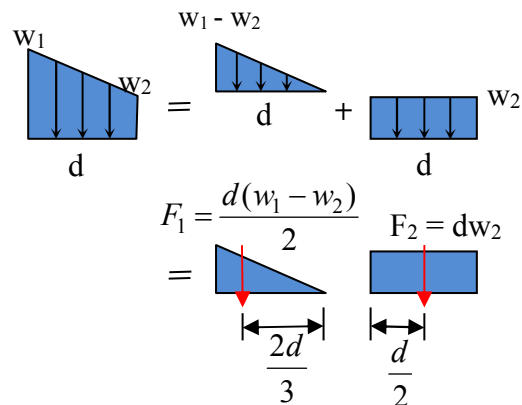

Figure 50 : distributed loads

Reactions of simple beam can be obtained by considering the loaded beam in figure 48a.) using equilibrium equation in horizontal direction.

<b>International Association Of Certified Practicing Engineers</b>	<b>ENGINEERING MATERIALS AND THEIR STRENGTH</b>	<b>Page 114 of 151</b>
		<b>Rev: 02</b>
	<b>CPE LEVEL I TRAINING MODULE</b>	<b>Jan 2015</b>

$$\sum F_x = 0 \Rightarrow H_A - P_1 \cos \alpha = 0$$

$$\Rightarrow H_A = P_1 \cos \alpha$$

$$\sum M_B = 0 \Rightarrow -R_A L + (P_1 \sin \alpha)(L - a) + P_2(L - b) + qc^2/2 = 0$$

$$\sum M_A = 0 \Rightarrow R_B L - (P_1 \sin \alpha)(a) - P_2 b - qc(L - c/2) = 0$$

Thus,  $R_A$  and  $R_B$  can be obtained as

$$R_A = \frac{(P_1 \sin \alpha)(L - a)}{L} + \frac{P_2(L - b)}{L} + \frac{qc^2}{2L}$$

$$R_B = \frac{(P_1 \sin \alpha)(a)}{L} + \frac{P_2 b}{L} + \frac{qc(L - c/2)}{L}$$

In additional, reactions of cantilever beam can be obtained by considering the loaded beam in figure 48b.) using equilibrium equation in horizontal and vertical directions.

$$\sum F_x = 0 \Rightarrow H_A - \frac{5P_3}{13} = 0$$

$$\Rightarrow H_A = \frac{5P_3}{13}$$

$$\sum F_y = 0 \Rightarrow R_A = \frac{12P_3}{13} + \frac{(q_1 + q_2)b}{13}$$

$$\sum M_A = 0 \Rightarrow M_A = \frac{12P_3}{13} + \frac{q_1 b}{2}(L - 2b/3) + \frac{q_2 b}{2}(L - b/3)$$

Furthermore, for the overhanging beam as shown in figure 48c.)

$$\sum M_B = 0 \Rightarrow -R_A L + P_4(L - a) + M_1 = 0$$

$$\sum M_A = 0 \Rightarrow -P_4 a + R_B L + M_1 = 0$$

Thus,  $R_A$  and  $R_B$  can be obtained as

$$R_A = \frac{P_4(L - a) + M_1}{L}$$

$$R_B = \frac{P_4 a - M_1}{L}$$

<b>International Association Of Certified Practicing Engineers</b>	<b>ENGINEERING MATERIALS AND THEIR STRENGTH</b>	<b>Page 115 of 151</b>
	<b>CPE LEVEL I TRAINING MODULE</b>	
	<b>Rev: 02</b>	
		<b>Jan 2015</b>

### b. Shear Forces and Bending Moments

Shear force ( $v$ ) is the algebraic sum of all vertical external forces to one side, either to the left or right of section. However, bending moment ( $M$ ) is the algebraic sum of the moments of the external forces, and couple, respectively, to one side of section (defined by an arbitrary longitudinal coordinate  $x$ ) about an axis through it. Shear forces and bending moments are the resultants of stresses distributed over the cross section. Therefore, these quantities are known collectively as stress resultants. The stress resultants in statically determinate beams can be calculated from equations of equilibrium<sup>[12]</sup>. Consider a cantilever beam with a concentrated load  $P$  applied at the end  $A$ , at the cross section  $mn$  in figure 51.

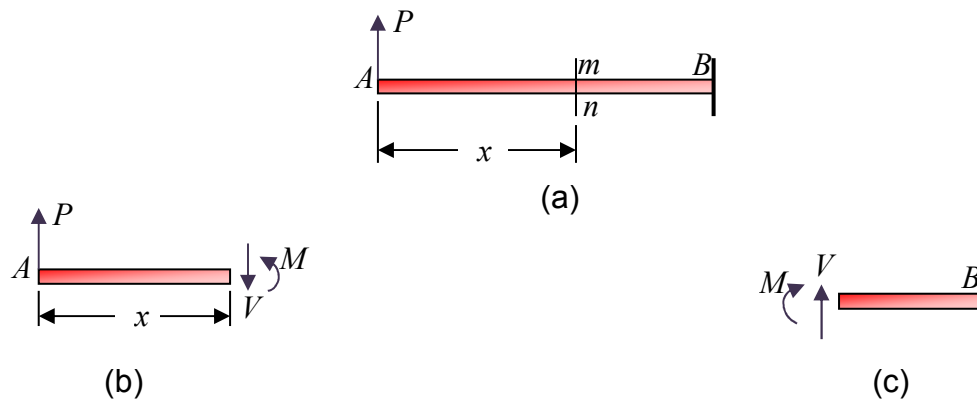

Figure 51 : cantilever beam

The shear force (upward is positive) and bending moment are found by

$$\begin{aligned} \sum F_{vertical} = 0 & \Rightarrow P - V = 0 \text{ or } V = P \\ \sum M = 0 & \Rightarrow M - Px = 0 \text{ or } M = Px \end{aligned}$$

### c. Sign Conventions

The sign convention for shear forces and bending moments are not based on their directions along the coordinates axes. The shear force tends to rotate the material clockwise is defined as positive. The bending moment tends to compress the upper part of the beam (counterclockwise) and elongate the lower part is defined as positive, and vice versa. They are shown in figure 52.

<b>International Association Of Certified Practicing Engineers</b>	<b>ENGINEERING MATERIALS AND THEIR STRENGTH</b>	<b>Page 116 of 151</b>
	<b>CPE LEVEL I TRAINING MODULE</b>	
	<b>Rev: 02</b>	
		<b>Jan 2015</b>

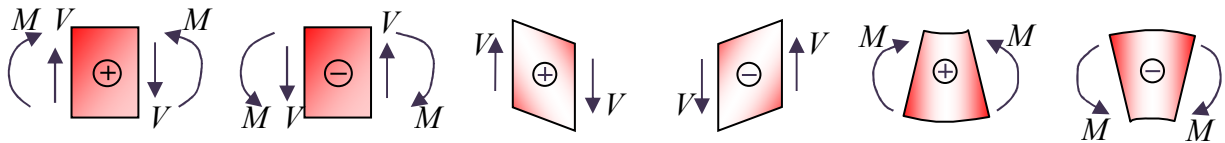

Figure 52 : sign conventions for shear force V and bending M

#### d. Shear Force and Bending Moment Diagram

The determination of the maximum absolute values of the shear and of the bending moment in a beam are greatly facilitated if V and M are plotted against the distance x measured from one end of the beam. To provide a clear understanding of these diagrams, following problem example explains the solution<sup>[30]</sup>.

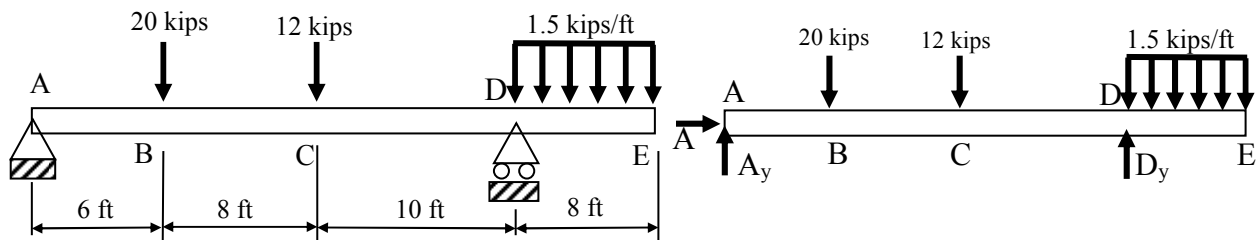

Figure 53 : example force and bending moment diagram

Step 1 : Find the reaction forces at A and D.

$$\sum F_x = 0 \Rightarrow A_x = 0$$

$$\sum M_A = 0 \Rightarrow (D_y)(24 \text{ ft}) - (20 \text{ kips})(6 \text{ ft}) - (12 \text{ kips})(14 \text{ ft}) - (1.5 \text{ kips/ft})(8 \text{ ft})(28 \text{ ft}) = 0$$

$$D_y = 26 \text{ kips}$$

$$\sum F_y = 0 \Rightarrow A_y + D_y - 20 \text{ kips} - 12 \text{ kips} - (1.5 \text{ kips/ft})(8 \text{ ft}) = 0$$

$$A_y = 18 \text{ kips}$$

Step 2 : Construct the shear force diagram

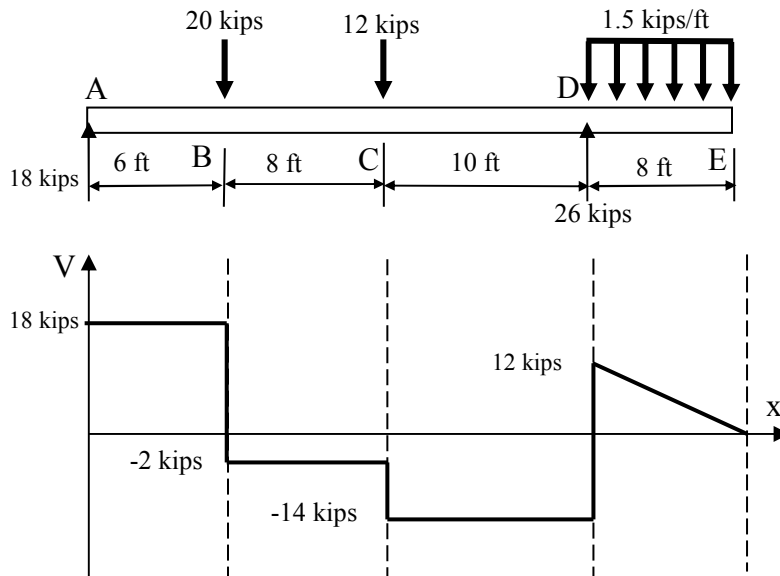

The shear force diagram is built based on following description :

1.  $V = A_y = 18$  kips at point A.
2. The shear force is constant until there is another load applied at B.
3. The shear force decreases by 20 kips to  $-2$  kips at B because of the applied 20 kip force in the negative y direction.
4. The shear force is constant until there is another load applied at C.
5. The shear force decreases by 12 kips to  $-14$  kips at C because of the applied 12 kip force in the negative y direction.
6. The shear force is constant until there is another load applied at D.
7. The shear force increases by 26 kips to 12 kips at D because of the 26 kip reaction force in the positive y direction.
8. The shear force decreases linearly from D to E because there is a constant applied load in the negative y-direction.
9. The change in shear force from D to E is equal to the area under the load curve between D and E,  $-12$  kips,  $[A_{DE} = (-1.5 \text{ kips/ft})(8 \text{ ft}) = -12 \text{ kips}]$ .
10. The shear force at E = 0 as expected by inspection of the boundary conditions.

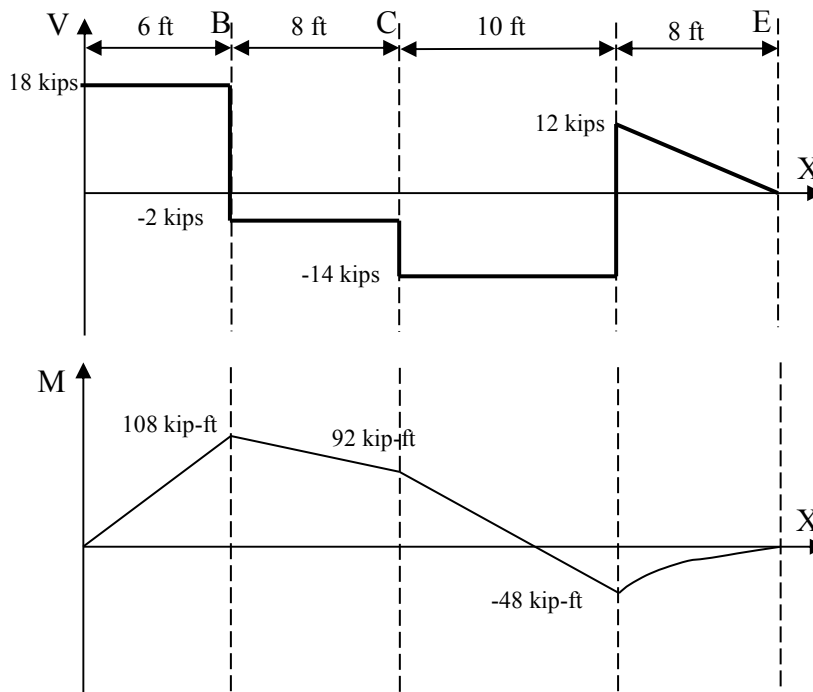

The bending moment diagram is made based on following description :

1.  $M = 0$  at point A because it is a pinned end with no applied bending moment.
2.  $M_B = M_A +$  (the area under the shear force diagram between A and B.)  
 $M_B = 0 + (18 \text{ kips})(6 \text{ ft}) = 108 \text{ kip-ft}$
3.  $M_C = M_B +$  (the area under the shear force diagram between B and C.)  
 $M_C = 108 \text{ kip-ft} - (2 \text{ kips})(8 \text{ ft}) = 92 \text{ kip-ft}$
4.  $M_D = M_C +$  (the area under the shear force diagram between C and D.)  
 $M_D = 92 \text{ kip-ft} - (14 \text{ kips})(10 \text{ ft}) = -48 \text{ kip-ft}$
5.  $M_E = M_D +$  (the area under the shear force diagram between D and E.)  
 $M_E = -48 \text{ kip-ft} + 1/2 (12 \text{ kips})(8 \text{ ft}) = 0 \text{ kip-ft}$  (as expected).

<b>International Association Of Certified Practicing Engineers</b>	<b>ENGINEERING MATERIALS AND THEIR STRENGTH</b>	<b>Page 119 of 151</b>
		<b>Rev: 02</b>
	<b>CPE LEVEL I TRAINING MODULE</b>	<b>Jan 2015</b>

### D. Pure Bending

Beams generally have higher stresses than axially loaded members and most engineering problems involve bending. Examples of beams include structural members, shafts, axles, levers, and gear teeth.

Knowing the shear and moment at any location in a beam is only useful if that information can be used to design a beam. The shear and moment need to be used to determine the stresses which can be used to find if the material will fail. To understand the bending stress in an arbitrary loaded beam, consider a small element cut from the beam as shown in figure 54<sup>[27]</sup>.

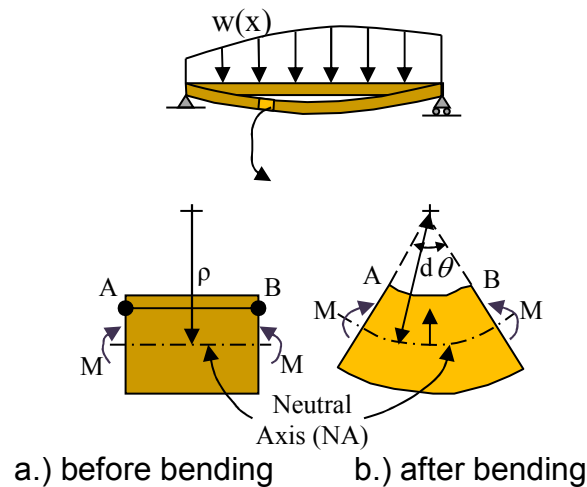

Figure 54 : small beam element in bending

The beam type or actual loads does not effect the derivation of bending strain equation as in Eq (23). Using the line segment, AB, the before and after length as shown in figure, can be used to give

$$\epsilon = \frac{\overline{A'B'} - \overline{AB}}{\overline{AB}} \quad \text{Eq (62)}$$

The line AB and A'B' can be described using the radius of curvature,  $\rho$ , and the differential angle,  $d\theta$  as follow.

$$\overline{AB} = \rho d\theta \quad \text{Eq (63)}$$

<b>International Association Of Certified Practicing Engineers</b>	<b>ENGINEERING MATERIALS AND THEIR STRENGTH</b>	<b>Page 120 of 151</b>
	<b>CPE LEVEL I TRAINING MODULE</b>	
	<b>Jan 2015</b>	

$$\overline{A'B'} = (\rho - y)d\theta \quad \text{Eq (64)}$$

Notice that the y coordinate is assumed upward from the neutral axis, where there is no strain. Putting these together gives (bending strain),

$$\epsilon = \frac{(\rho - y)d\theta - \rho d\theta}{\rho d\theta} = -\frac{y}{\rho} \quad \text{Eq (65)}$$

This relationship gives the bending strain at any location as a function of the beam curvature and the distance from the neutral axis. However, this equation is of little use, and needs to be converted to stress by Hooke's law in Eq (26). Thus, it can be determined as follow.

$$\sigma = -E \frac{y}{\rho} \quad \text{Eq (66)}$$

This relationship can be determined by summing the moment due to the normal stresses on an arbitrary beam cross section and equating it to the applied internal moment. This is the same as applying the moment equilibrium equation about the neutral axis (NA).

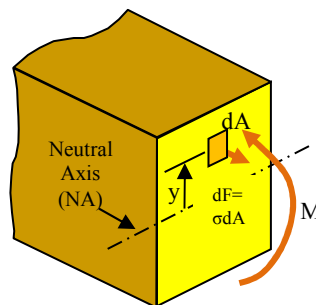

Figure 55 : beam section cut

Hence, moment equilibrium equation about the neutral axis becomes

$$\begin{aligned} \sum M_{NA} &= 0 \\ \int y(-dF) &= M \\ - \int y\sigma dA &= M \end{aligned}$$

<b>International Association Of Certified Practicing Engineers</b>	<b>ENGINEERING MATERIALS AND THEIR STRENGTH</b>	<b>Page 121 of 151</b>
	<b>CPE LEVEL I TRAINING MODULE</b>	<b>Rev: 02</b>
		<b>Jan 2015</b>

$$\frac{E}{\rho} \int y^2 dA = M$$

It is interesting to note that the integral is the area moment of inertia,  $I$ , or the second moment of the area. In addition, radius of curvature is difficult to determine at a given beam location, thus it must be eliminated by substituting Eq (66).

$$\frac{EI}{\rho} = M \quad \text{Eq (67)}$$

$$\frac{EI}{(-Ey / \sigma)} = M \quad \text{Eq (68)}$$

Therefore, bending stress or flexure formula can be defined by

$$\sigma = -\frac{My}{I} \quad \text{Eq (69)}$$

Signs of bending moments state that the stress is compressive ( $\sigma < 0$ ) above the neutral axis ( $y > 0$ ) when the bending moment  $M$  is positive, and tensile ( $\sigma > 0$ ) when  $M$  is negative<sup>[3]</sup>.

The maximum magnitude of the bending stress will occur where  $y$  has the greatest magnitude. Designating  $\sigma_{\max}$  as the maximum magnitude of the bending stress, and  $c$  as the maximum magnitude of  $y$ .  $c$  can be shown in following figure<sup>[6]</sup>.

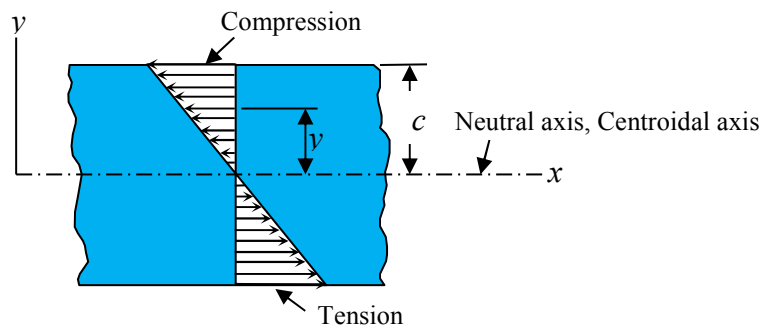

Figure 56 : bending stress

<b>International Association Of Certified Practicing Engineers</b>	<b>ENGINEERING MATERIALS AND THEIR STRENGTH</b>	Page 122 of 151
		Rev: 02
		Jan 2015
<b>CPE LEVEL I TRAINING MODULE</b>		

Hence, maximum magnitude of the bending stress is determined by

$$\sigma_{\max} = \frac{Mc}{I} \quad \text{Eq (70)}$$

Another maximum magnitude of bending stress equation is often written as

$$\sigma_{\max} = \frac{|M|}{S} \quad \text{Eq (71)}$$

Where,

- $\sigma$  : bending stress, psi (Pascal / N/m<sup>2</sup>)
- M : bending moment, lbf.in (Nm)
- S : elastic section modulus, I/c, in<sup>3</sup> (m<sup>3</sup>)
- y : distance from centroid to the point considered, in (m)
- I : second moment of area of section lbf.in<sup>2</sup> (kg.m<sup>2</sup>)

### E. Transformation of Stress

The stress transformations are simplest in the case of plane stress and can be done in several ways. In any case, at a given point in a material there is only one state of stress at a particular instant. At the same time, the components of the stresses depend on the orientation of the chosen coordinate system.

The stress transformation equations depend on the chosen coordinate system and the sign convention adopted. Three dimensional view of an element in plane stress is oriented to the xyz axes. Whereas, two dimensional view of the same element is oriented to the xy axes. For equilibrium, in most cases, in two dimensional, “cross-shears” are equal, hence

$$\tau_{yx} = \tau_{xy} \quad \tau_{zy} = \tau_{yz} \quad \tau_{xz} = \tau_{zx} \quad \text{Eq (72)}$$

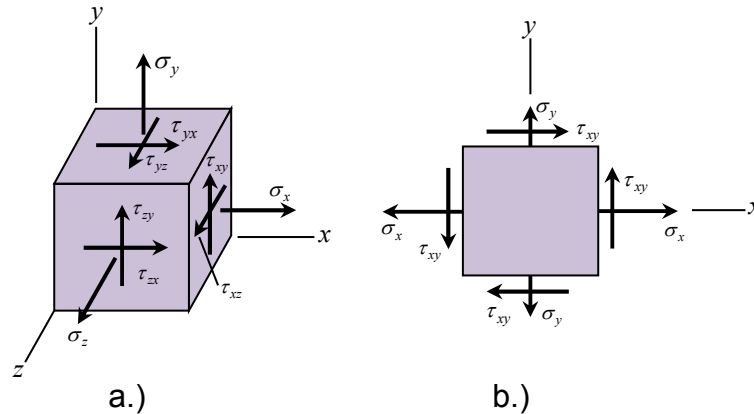

Figure 57 : element in plane stress

#### a. Mohr's Circle for Plane Stress

The Mohr circle is an elegant way to determine the shear and normal stresses for a pair of stresses oriented obliquely to the plane. Suppose the  $dx\ dy\ dz$  element of Figure 57b is cut by an oblique plane with a normal  $n$  at an arbitrary angle  $\phi$  counterclockwise from the  $x$  axis as shown in Figure 58.

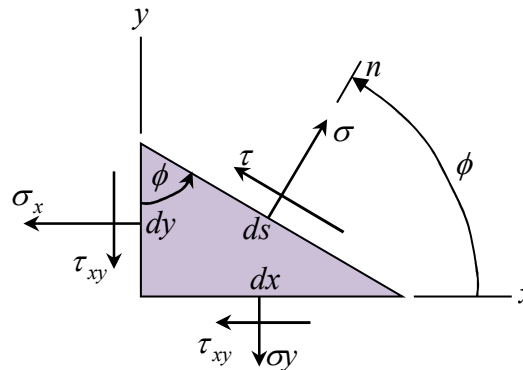

Figure 58 : an oblique plane

By summing the forces caused by all the stress components to zero, plane-stress transformation can be defined by

$$\sigma = \frac{\sigma_x + \sigma_y}{2} + \frac{\sigma_x - \sigma_y}{2} \cos 2\phi + \tau_{xy} \sin 2\phi \quad \text{Eq (73)}$$

<b>International Association Of Certified Practicing Engineers</b>	<b>ENGINEERING MATERIALS AND THEIR STRENGTH</b>	Page 124 of 151
		Rev: 02
	<b>CPE LEVEL I TRAINING MODULE</b>	Jan 2015

$$\tau = -\frac{\sigma_x - \sigma_y}{2} \sin 2\phi + \tau_{xy} \cos 2\phi \quad \text{Eq (74)}$$

Differential Eq (73) with respect to  $\phi$  and setting the result equal to zero gives

$$\tan 2\phi_p = \frac{2\tau_{xy}}{\sigma_x - \sigma_y} \quad \text{Eq (75)}$$

Equation (75) defines two particular values for the angle  $2\phi_p$ , one of which defines the maximum normal stress  $\sigma_1$  and the other, the minimum normal stress  $\sigma_2$ . These two stresses are called the principal stresses, and their corresponding directions, the principal directions. The angle between the principal directions is  $90^\circ$  and it means that the surface containing principal stresses have zero shear stresses.

It is important to note that Eq (75) can be written in the form

$$\frac{\sigma_x - \sigma_y}{2} \sin 2\phi_p - \tau_{xy} \cos \phi_p = 0 \quad \text{Eq (76)}$$

Extreme angle value of shear stress can be obtained by differentiating Eq (74) with respect to  $\phi$  and setting the result equal to zero. It becomes,

$$\tan 2\phi_s = -\frac{\sigma_x - \sigma_y}{2\tau_{xy}} \quad \text{Eq (77)}$$

The angle between the surfaces containing the maximum shear stresses is  $90^\circ$ . Equation (77) can also be written as

$$\frac{\sigma_x - \sigma_y}{2} \cos 2\phi_p + \tau_{xy} \sin \phi_p = 0 \quad \text{Eq (78)}$$

Substituting above equation into Eq (73), It results that this stress acts on planes oriented  $45^\circ$  from the planes of principal stress. There is a normal stress on these planes of  $\tau_{\max}$ , the average of  $\sigma_x$  and  $\sigma_y$ ,

$$\sigma = \frac{\sigma_x + \sigma_y}{2} \quad \text{Eq (79)}$$

<b>International Association Of Certified Practicing Engineers</b>	<b>ENGINEERING MATERIALS AND THEIR STRENGTH</b>	<b>Page 125 of 151</b>
		<b>Rev: 02</b>
	<b>CPE LEVEL I TRAINING MODULE</b>	<b>Jan 2015</b>

Formulas for the two principal stresses can be obtained by substituting the angle  $2\phi_p$ .

$$\sigma_1, \sigma_2 = \frac{\sigma_x + \sigma_y}{2} \pm \sqrt{\left(\frac{\sigma_x - \sigma_y}{2}\right)^2 + \tau_{xy}^2} \quad \text{Eq (80)}$$

Similarly, the maximum and minimum values of the shear stresses (extreme shear stresses) are obtained using

$$\tau_1, \tau_2 = \pm \sqrt{\left(\frac{\sigma_x - \sigma_y}{2}\right)^2 + \tau_{xy}^2} \quad \text{Eq (81)}$$

Radius of circle also can be defined by

$$R = \sqrt{\left(\frac{\sigma_x - \sigma_y}{2}\right)^2 + \tau_{xy}^2} \quad \text{Eq (82)}$$

### b. Mohr's Circle Diagram

Mohr's circle diagram is a graphical method to visualize the stress state. The normal stresses are plotted along the abscissa axis of the coordinate system and the shear stresses along the ordinate axis. This convention is followed in drawing Mohr's circle:

- Shear stresses tending to rotate the element clockwise (cw) are plotted above the  $\sigma$  axis.
- Shear stresses tending to rotate the element counterclockwise (ccw) are plotted below the  $\sigma$  axis.

In Mohr's circle diagram, a coordinate system with normal stresses plotted along the abscissa and shear stresses plotted as the ordinates. On the abscissa, tensile (positive) normal stresses are plotted to the right of the origin O and compressive (negative) normal stresses to the left. On the ordinate, clockwise (cw) shear stresses are plotted up; counterclockwise (ccw) shear stresses are plotted down<sup>[6]</sup>.

<b>International Association Of Certified Practicing Engineers</b>	<b>ENGINEERING MATERIALS AND THEIR STRENGTH</b>	<b>Page 126 of 151</b>
		<b>Rev: 02</b>
		<b>Jan 2015</b>
<b>CPE LEVEL I TRAINING MODULE</b>		

Steps to construct Mohr's circle diagram<sup>[15]</sup> :

1. Draw the  $\sigma$  and  $\tau$  axes and locate points A of  $\sigma_x$  and C of  $\sigma_y = 0$  on the  $\sigma$  axis.
2. Locate points of  $\tau_{xy}$  in the cw direction and  $\tau_{yx}$  in the ccw direction. Hence, points B has the coordinates  $\sigma_x$  and  $\tau_{xy}$  and point D the coordinates  $\sigma_y = 0$  and  $\tau_{yx}$ .
3. Locate point E as the center of the Mohr's circle. The intersection of the circle with the  $\sigma$  axis gives the principal stresses  $\sigma_1$  and  $\sigma_2$  at points F and G, respectively.
4. Using point E as the center, draw Mohr's circle through points B and D. The circle drawn in this manner has radius R that can be calculated by Eq (82).
5. Calculate  $\sigma_1$  by summing distance from A to E and R; along with calculate  $\sigma_2$  by reducing distance from C to E to R.
6. Calculate the angle  $2\phi_p$  from the x axis cw to  $\sigma_1$ .
7. Then, draw the principal stress element by sketching the x and y axes parallel to the original axes in the same direction as is the angle  $2\phi_p$ . Thus, from x, measure  $\phi_p$  clockwise or counterclockwise based on the first, to locate the  $\sigma_1$  axis. The axis will be at  $90^\circ$  with respect to the axis, as shown in Figure 59b.
8. Draw second stress element, it respects to the two extreme shear stresses at point H and I. The two normal stresses corresponding to the shear stresses. Then, calculate shear stress angle ( $2\phi_s$ ) by measuring angle ccw or cw (opposite from first direction) from point B to H. Therefore,  $\phi_s$  of a stress element can be obtained from x as shown in Figure 59c.



<b>International Association Of Certified Practicing Engineers</b>	<b>ENGINEERING MATERIALS AND THEIR STRENGTH</b>	<b>Page 128 of 151</b>
	<b>CPE LEVEL I TRAINING MODULE</b>	
	<b>Rev: 02</b>  <b>Jan 2015</b>	

### F. Applications of Stresses in Mechanical Elements

In many components, the load may be suddenly applied to give stresses much higher than the steady stress. Therefore, maximum tensile stress should be determined for safety. An example of stress due to a falling mass process is given in Figure 60, while stress due to a moving part at amount velocity is given in Figure 61.

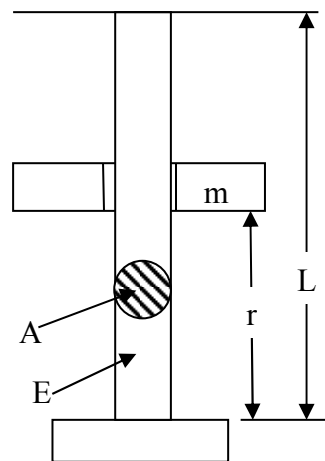

Figure 60 : stress due to the falling mass

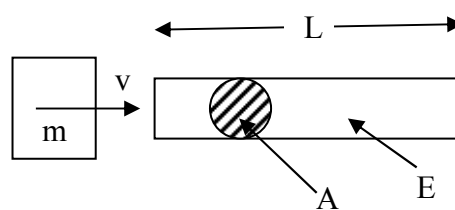

Figure 61 : stress due to the moving part

The maximum tensile stress is :

$$\sigma_m = \sigma_s \left[ 1 + \sqrt{\left( \frac{2h}{x_s} \right)} \right] \quad \text{Eq (83)}$$

<b>International Association Of Certified Practicing Engineers</b>	<b>ENGINEERING MATERIALS AND THEIR STRENGTH</b>	<b>Page 129 of 151</b>
		<b>Rev: 02</b>
	<b>CPE LEVEL I TRAINING MODULE</b>	<b>Jan 2015</b>

Where,

$$\sigma_s = \frac{m \cdot g}{A} \quad \text{Eq (84)}$$

$$x_s = \frac{m \cdot g \cdot L}{A \cdot E} \quad \text{Eq (85)}$$

Stress equation due to a 'suddenly-applied' load ( $h = 0$ ) is :

$$\sigma_m = 2\sigma_s \quad \text{Eq (86)}$$

And stress due to a mass  $M$  moving at any velocity is formulated as :

$$\sigma_m = v \sqrt{\frac{m \cdot E}{A \cdot L}} \quad \text{Eq (87)}$$

Where,

- $\sigma_m$  : Maximum tensile stress, psi (Pascal / N/m<sup>2</sup>)
- $\sigma_s$  : Steady stress, psi (Pascal / N/m<sup>2</sup>)
- $x_s$  : Steady extension, in (m)
- $h$  : Height fallen mass, in (m)
- $A$  : Area of cross section, in<sup>2</sup> (m<sup>2</sup>)
- $v$  : Velocity, in/s (m/s)

### a. Stresses in Knuckle Joint

The knuckle joint is a good example of the application of simple stress calculations. The various stresses which typically occurred are given in table 24.

Table 24 : stresses in knuckle joint

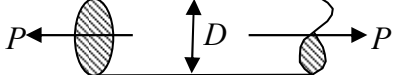
Stress types	Figure	Formula
Tensile in rod		$\sigma_t = \frac{4P}{\pi D^2}$

<b>International Association Of Certified Practicing Engineers</b>	<b>ENGINEERING MATERIALS AND THEIR STRENGTH</b>	<b>Page 130 of 151</b>
	<b>CPE LEVEL I TRAINING MODULE</b>	
	<b>Rev: 02</b>  <b>Jan 2015</b>	

Continued from Table 24

Stress types	Figure	Formula
Tensile in eye		$\sigma_t = \frac{P}{(D_o - D_p)b}$
Tensile in fork		$\sigma_f = \frac{P}{(D_o - D_p)2a}$
Crushing eye		$\sigma_c = \frac{P}{bD_p}$
Crushing in fork		$\sigma_c = \frac{P}{2D_p a}$
Shear in pin		$\tau = \frac{2P}{\pi D_p^2}$

Where,

- P : Load, lb (N)
- $\sigma_t$  : Tensile stress, psi (Pascal / N/m<sup>2</sup>)
- $\sigma_b$  : Bending stress, psi (Pascal / N/m<sup>2</sup>)
- $\sigma_c$  : Crushing stress, psi (Pascal / N/m<sup>2</sup>)
- $\tau$  : Shear stress, psi (Pascal / N/m<sup>2</sup>)
- D : Rod diameter, in (m)

<b>International Association Of Certified Practicing Engineers</b>	<b>ENGINEERING MATERIALS AND THEIR STRENGTH</b>	<b>Page 131 of 151</b>
		<b>Rev: 02</b>
	<b>CPE LEVEL I TRAINING MODULE</b>	<b>Jan 2015</b>

- Dp : Pin diameter, in (m)
- Do : Eye outer diameter, in (m)
- a : Thickness of the fork, in (m)
- b : The thickness of the eye, in (m)

### b. Strength of Fastener

Almost any material can be joined with adhesives, though ensuring a sound, durable bond can be difficult. Bolting, riveting, stapling, and snap fitting are commonly used to join polymers and metals, and have the feature that they can be disassembled if need be. Welding, the largest class of joining processes, is widely used to bond metals and polymers; specialized techniques have evolved to deal with each class<sup>[1]</sup>. This section explains briefly about bolt and bolted joints, and welds.

#### i. Bolts and Bolted Joints

Bolts that usually conjoined with nuts are the most widely used for a non-permanent fastening. The head of bolt is hexagonal-shaped but sometimes could also be another shape like circle-shaped or square-shaped. The shank is screwed with a vee thread for all or part of its length. Generally, bolts are made from a low or medium range carbon steel by forging or machining and threads are formed by a cutting or rolling process<sup>[10]</sup>.

'Black' is another name for forged bolts, while 'bright' is for the machined bolts. Both of them could be made from a high tensile steel (often called 'HT bolts'), stainless steel, alloy steel, brass, or other metals. Nuts are usually hexagonal-shaped that probably black or bright. A bolted joint may use a 'through bolt', a 'tap bolt' or a 'stud'. Many types of bolts with a hexagonal socket head are used. They are usually made from high tensile steel and require a special wrench. Figure 62 to Figure 69 show examples of bolts kind, its shape, the head, and the nuts as applied in the field.

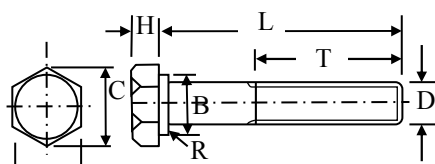

Figure 62: Hexagonal head bolt

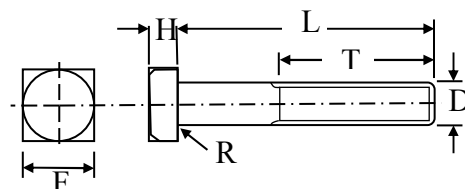

Figure 63: Square head bolt

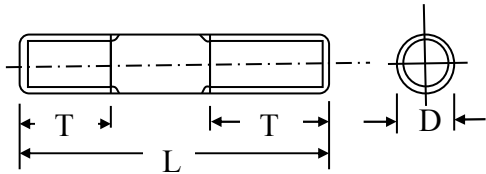

Figure 64: Stud bolt

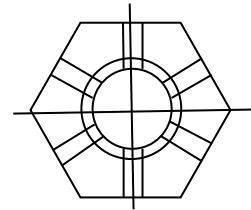

Figure 65: Slotted nut

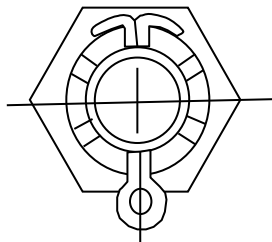

Figure 66 : Castle nut

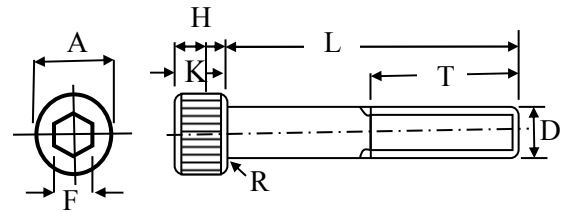

Figure 67: Hexagonal socket head screw  
(L/T according to application)

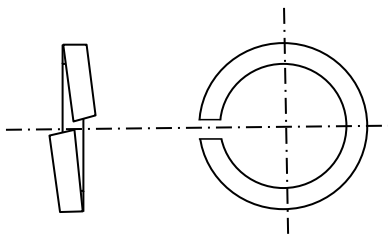

Figure 68: helical spring lock washer

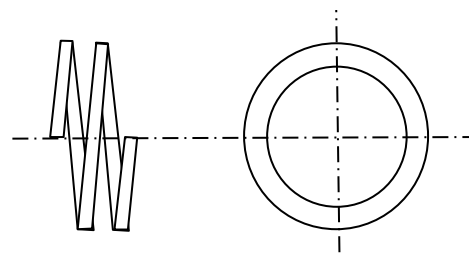

Figure 69: two-coil spring lock washer

Where,

- D : Outside or major diameter of thread, in (mm)
- L : Length of shank, in (mm)
- T : Length of thread, in (mm)
- H : Height of head, in (mm)
- F : Distance across flats, in (mm)
- C : Distance across corners, in (mm)
- R : Radius of fillet under head, in (mm)
- B : Bearing diameter, in (mm)

<b>International Association Of Certified Practicing Engineers</b>	<b>ENGINEERING MATERIALS AND THEIR STRENGTH</b>	<b>Page 133 of 151</b>
	<b>CPE LEVEL I TRAINING MODULE</b>	<b>Rev: 02</b>
		<b>Jan 2015</b>

The nominal size of bolts and its dimension that usually applied is represented in table 25.

Table 25: bolts size

Nominal Size	D	H	F	Thread Pitch	
				Coarse	Fine
M10	10	7	17	1.5	1.25
M12	12	8	19	1.75	1.25
M16	16	10	24	2.0	1.5
M20	20	13	30	2.5	1.5

### Bolted Joint in Tension

The bolt under tensile load plus an initial tightening load condition is represented in figure 70. The three members are shown bolted together but the method can be applied to any number of members.

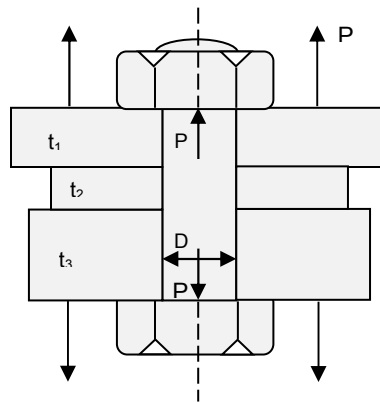

Figure 70 : bolted joint in tension

In this case, shear stress in bolt is defined by

$$\tau_{\max} = \sqrt{\left(\frac{P}{2A_r}\right)^2 + \left(\frac{16T}{\pi D^3}\right)^2} \quad \text{Eq (88)}$$

<b>International Association Of Certified Practicing Engineers</b>	<b>ENGINEERING MATERIALS AND THEIR STRENGTH</b>	Page 134 of 151
		Rev: 02
	<b>CPE LEVEL I TRAINING MODULE</b>	Jan 2015

Based on the equation, total load can be obtained by

$$P = P_t + P_e \frac{\sum x}{\sum x + x_b} \quad \text{Eq (89)}$$

Where the deflection of bolt and member per load can be formulated as

$$x_b = \frac{L}{A_b E_b} \quad \text{Eq (90)}$$

$$x_1 = \frac{t_1}{A_1 E_1} \quad \text{Eq (91)}$$

$$x_2 = \frac{t_2}{A_2 E_2} \quad \text{Eq (92)}$$

In additional, tightening is also concerned as follow.

Hand tightening can be obtained by

$$P_t = kD \quad \text{Eq (93)}$$

Torque-wrench tightening is determined by

$$P_t = \frac{T}{0.2D} \quad \text{Eq (94)}$$

Where,

- $P_e$  : External load, lb (N)
- $P_t$  : Tightening load, lb (N)
- $P$  : Total load, lb (N)
- $A$  : Area of a member ( $A_1, A_2$ , etc) , in<sup>2</sup> (m<sup>2</sup>)
- $A_b$  : Bolt cross-sectional area, in<sup>2</sup> (m<sup>2</sup>)
- $t$  : Thickness of a member ( $t_1, t_2$ , etc) , in (m)
- $L$  : Length of bolt, in (m)
- $E$  : Young modulus ( $E_b, E_1$ , etc) , psi (Pascal / N/m<sup>2</sup>)

<b>International Association Of Certified Practicing Engineers</b>	<b>ENGINEERING MATERIALS AND THEIR STRENGTH</b>	<b>Page 135 of 151</b>
		<b>Rev: 02</b>
	<b>CPE LEVEL I TRAINING MODULE</b>	<b>Jan 2015</b>

- x : Deflection of member per unit load
- $x_b$  : Deflection of bolt per unit load
- D : Bolt diameter, in (m)
- $D_r$  : Bolt thread root diameter, in (m)
- $A_r$  : Area at thread root, in<sup>2</sup> (m<sup>2</sup>)
- T : Bolt tightening torque, lb.in (N.m)

## ii. Strength of Welds

A welding joint is a point or edge where two or more pieces of metal or plastic are joined together. They are formed by welding two or more workpieces (metal or plastic) according to a particular geometry. Five types of joints referred to by the American Welding Society: butt, corner, edge, lap, and tee. These configurations may have various configurations at the joint where actual welding can occur. Figures 71 to 73 illustrate the butt weld and fillet weld.

A well-made 'butt weld' has a strength at least equal to that of the plates joined. An example of a 'fillet weld' in shear the cross section is assumed to be a 45° right-angle triangle with the shear area at 45° to the plates. For brackets, it is assumed that the weld area is flattened and behaves like a thin section in bending. For ease of computation the welds are treated as thin lines. Since fillet welds result in discontinuities and hence stress concentration, it is necessary to use stress concentration factors when fluctuating stress is present<sup>[10]</sup>.

For general machine elements most welds are fillet welds, though butt welds are used a great deal in designing pressure vessels. The parts to be joined must be arranged so that there is sufficient clearance for the welding operation<sup>[6]</sup>.

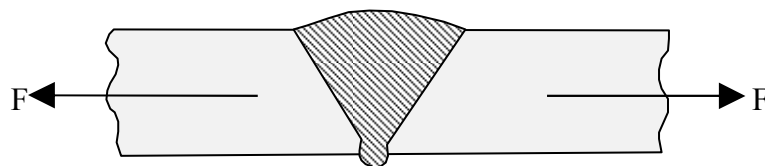

Figure 71 : butt Weld

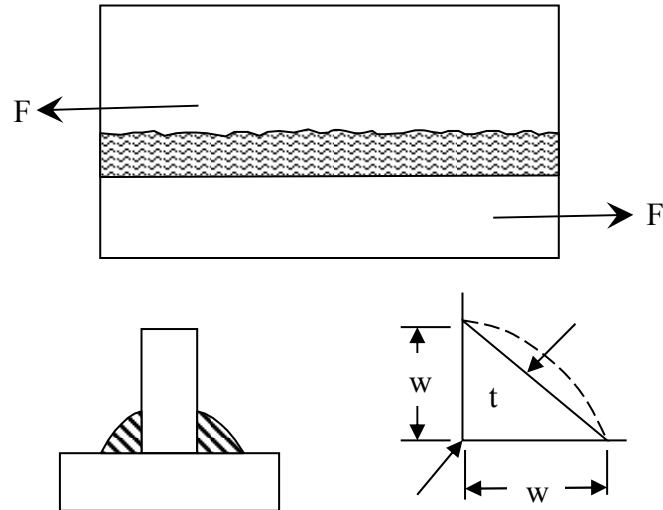

Figure 72 : fillet weld with parallel loading

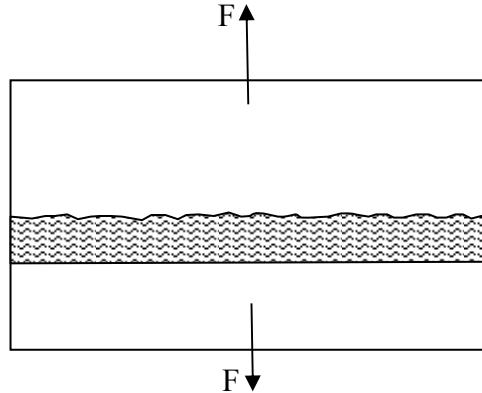

Figure 73: fillet weld with transverse loading

For parallel loading, shear stress can be defined by

$$\tau = \frac{F}{t \cdot L}$$

Eq (95)

Where,

- t = weld throat,  $t \cong 0.7 \cdot w$ , in (m)
- w = weld leg size, in (m)
- L = length, in (m)

<b>International Association Of Certified Practicing Engineers</b>	<b>ENGINEERING MATERIALS AND THEIR STRENGTH</b>	<b>Page 137 of 151</b>
		<b>Rev: 02</b>
	<b>CPE LEVEL I TRAINING MODULE</b>	<b>Jan 2015</b>

For transverse loading, shear stress is obtained by using Eq (95) with weld throat is

$$t = 0.77 \cdot w \quad \text{Eq (96)}$$

### c. Stresses due to rotation

Flywheels are used to store large amounts of energy and are therefore usually very highly stressed. It is necessary to be able to calculate the stresses accurately. Formulas are given for the thin ring, solid disk, annular wheel, spoked wheel, and also the rotating thick cylinder. Figure 74 to Figure 77 shows the example of each rotation kind.

#### 1. Thin Ring

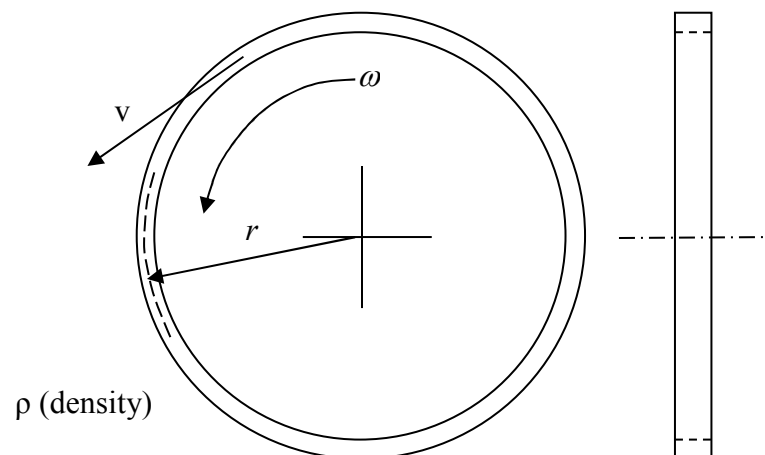

Figure 74 : thin ring

Stress at thin ring is defined as tangential stress that is expressed by

$$\sigma_t = \rho v^2 = \rho \cdot r^2 \cdot \omega^2 \quad \text{Eq (97)}$$

Where,

- $\rho$  : density, lb/ft<sup>3</sup> (kg/m<sup>3</sup>)
- $r$  : mean radius, ft (m)
- $v$  : tangential velocity ( $r \cdot \omega$ ), rad/s

<b>International Association Of Certified Practicing Engineers</b>	<b>ENGINEERING MATERIALS AND THEIR STRENGTH</b>	<b>Page 138 of 151</b>
		<b>Rev: 02</b>
	<b>CPE LEVEL I TRAINING MODULE</b>	<b>Jan 2015</b>

## 2. Solid Disk

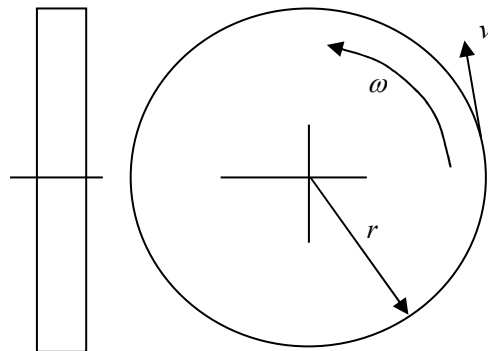

Figure 75: solid disk

Stress at solid disk is considered as maximum tangential and radial stress ( $\sigma_r$ ) which can be given by

$$\sigma_t = \sigma_r = \frac{\rho v^2 (3 + \nu)}{8} \text{ at } r = 0 \quad \text{Eq (98)}$$

Where,

- $\nu$  : poisson's ratio
- $v$  : tangential velocity ( $r \cdot \omega$ ), rad/s

## 3. Annular Wheel

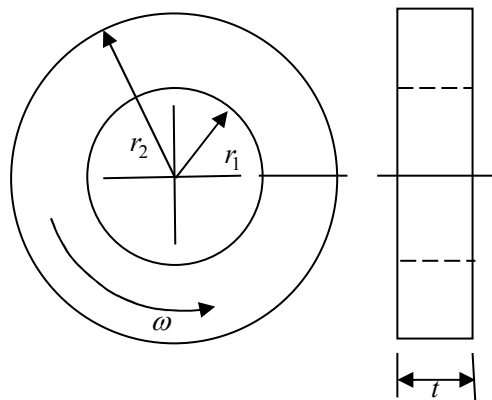

Figure 76 : annular wheel

<b>International Association Of Certified Practicing Engineers</b>	<b>ENGINEERING MATERIALS AND THEIR STRENGTH</b>	<b>Page 139 of 151</b>
		<b>Rev: 02</b>
	<b>CPE LEVEL I TRAINING MODULE</b>	<b>Jan 2015</b>

Stress at annular wheel is considered as maximum tangential stress for axial length assumed 'small' which can be given by

at  $r_1$ ,

$$\sigma_{t \max} = \rho v^2 \frac{(3+\nu)}{4} \left( 1 + \frac{(1-\nu)}{(3+\nu)} \left( \frac{r_1}{r_2} \right)^2 \right) \quad \text{Eq (99)}$$

At  $r = \sqrt{r_1 r_2}$ ,

$$\sigma_{r \max} = \rho v^2 \frac{(3+\nu)}{8} \left( 1 - \left( \frac{r_1}{r_2} \right)^2 \right) \quad \text{Eq (100)}$$

Where,

$v$  = tangential velocity,  $v = r_2 \omega$ , rad/s

#### 4. Spoked wheel

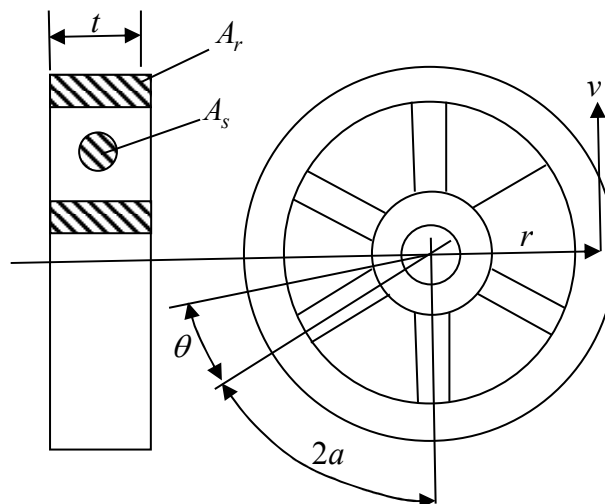

Figure 77: spoked wheel

Spoked wheel stress is considered as greatest tangential stress. Spoked wheel stress is also determined based on its number of spokes that is described in table 26.

<b>International Association Of Certified Practicing Engineers</b>	<b>ENGINEERING MATERIALS AND THEIR STRENGTH</b>	Page 140 of 151
		Rev: 02
	<b>CPE LEVEL I TRAINING MODULE</b>	Jan 2015

The spoked wheel stress can be defined by

At angle,

$$\sigma_t = \rho v^2 \left[ 1 - \frac{\cos \theta}{3c \sin \alpha} \pm \frac{2r}{ct} \left( \frac{1}{\alpha} - \frac{\cos \theta}{\sin \alpha} \right) \right] \quad \text{Eq (101)}$$

Where,

r : mean radius of rim, ft (m)

Table 26 : value of constant c against to number of spokes

No. of spokes	Value of constant c
4	$0.073 \left( \frac{r}{t} \right)^2 + 0.643 + \frac{A_r}{A_s}$
6	$0.0203 \left( \frac{r}{t} \right)^2 + 0.957 + \frac{A_r}{A_s}$
8	$0.0091 \left( \frac{r}{t} \right)^2 + 1.274 + \frac{A_r}{A_s}$

### 5. Long thick cylinder

At long thick cylinder, there are several stresses which are considered at maximum condition. They can be obtained by

Maximum tangential stress at  $r_1$  is defined as

$$\sigma_t = \frac{\rho v^2}{4(1-\nu)} \left[ (1-2\nu) + (3-2\nu) \left( \frac{r_1}{r_2} \right)^2 \right] \quad \text{Eq (102)}$$

Maximum radial stress at  $r = \sqrt{r_1 r_2}$  is given by

$$\sigma_r = \frac{\rho v^2 (3-2\nu)}{8(1-\nu)} \left( 1 - \frac{r_1}{r_2} \right)^2 \quad \text{Eq (103)}$$

<b>International Association Of Certified Practicing Engineers</b>	<b>ENGINEERING MATERIALS AND THEIR STRENGTH</b>	<b>Page 141 of 151</b>
	<b>CPE LEVEL I TRAINING MODULE</b>	
	<b>Rev: 02</b>	
		<b>Jan 2015</b>

Maximum axial stress with tensile at  $r_1$ , compressive at  $r_2$

$$\sigma_s = \frac{\rho v^2 (V)}{4(1-V)} \left(1 - \frac{r_1}{r_2}\right)^2 \quad \text{Eq (104)}$$

### G. Fatigue

Fatigue is usually occurred at a point of high stress concentration due to fluctuating stress distribution. A fluctuating stress is a combination of a static plus a completely reversed stress. The component of the stresses are depicted in Figure 78. Where  $\sigma_{\min}$  is a minimum stress and  $\sigma_{\max}$  is the maximum stress,  $\sigma_a$  the stress amplitude or the alternating stress,  $\sigma_m$  the midrange or the mean stress,  $\sigma_r$  the stress range, and  $\sigma_s$  the steady or static stress<sup>[15]</sup>.

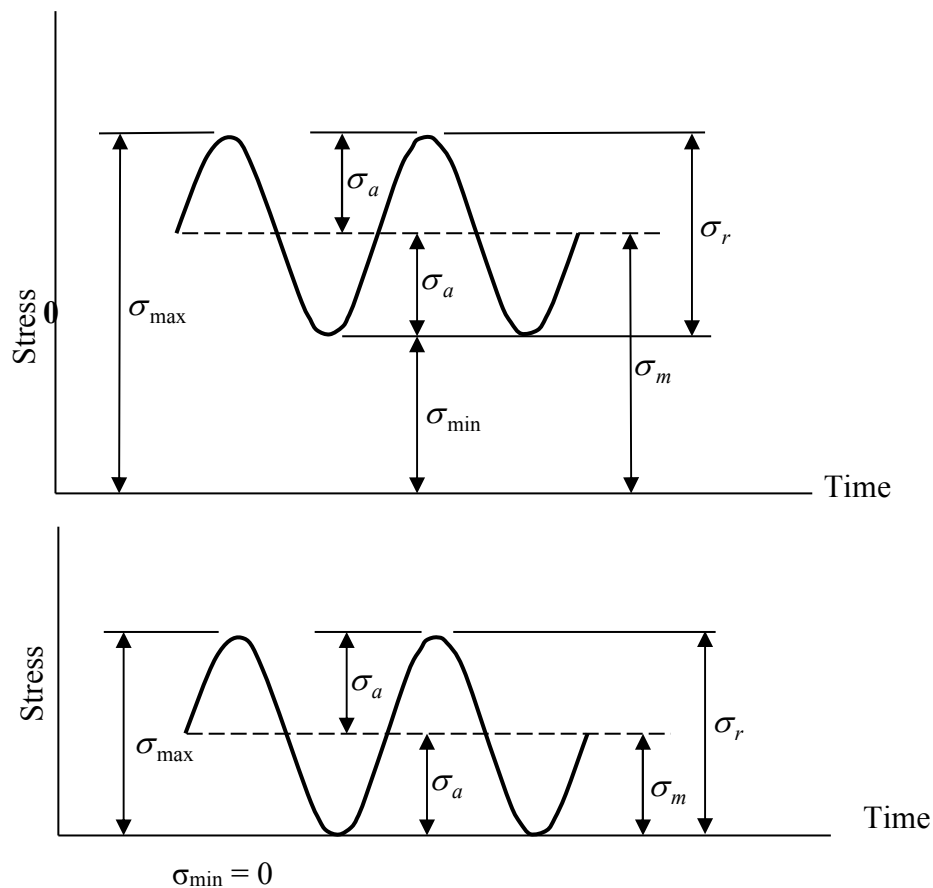

Figure 78 : fluctuating stresses

<b>International Association Of Certified Practicing Engineers</b>	<b>ENGINEERING MATERIALS AND THEIR STRENGTH</b>	<b>Page 142 of 151</b>
		<b>Rev: 02</b>
	<b>CPE LEVEL I TRAINING MODULE</b>	<b>Jan 2015</b>

The steady stress could have any value between  $\sigma_{\min}$  and  $\sigma_{\max}$  and exists because of a fixed load. It is usually independent of the varying portion of the load. The following relations between the stress components are useful :

$$\sigma_m = \frac{\sigma_{\max} + \sigma_{\min}}{2} \quad \text{Eq (105)}$$

$$\sigma_a = \frac{\sigma_{\max} - \sigma_{\min}}{2} \quad \text{Eq (106)}$$

The stress ratios are also used to describe the fluctuating stresses. They are expressed in R or A as follow

$$R = \frac{\sigma_{\min}}{\sigma_{\max}} \quad \text{Eq (107)}$$

$$A = \frac{\sigma_a}{\sigma_m} \quad \text{Eq (108)}$$

The event of fluctuating stress can cause a severe damage to the part of machine and also the machine its self as in general (failure). Failure achieved suddenly as a result of crack propagation without plastic deformation at a stress well below the elastic limit. The stress may be alternating (Figure 79), repeated (Figure 80) or could be combination of both (Figure 81).

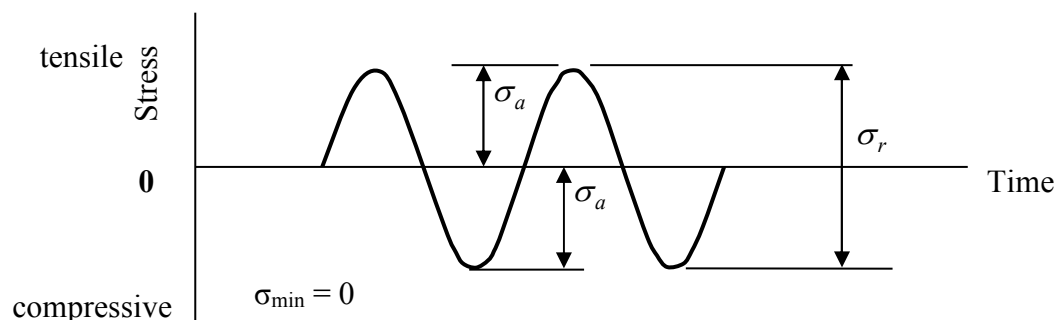

Figure 79 : alternating stress

<b>International Association Of Certified Practicing Engineers</b>	<b>ENGINEERING MATERIALS AND THEIR STRENGTH</b>	<b>Page 143 of 151</b>
	<b>CPE LEVEL I TRAINING MODULE</b>	
	<b>Rev: 02</b>	
		<b>Jan 2015</b>

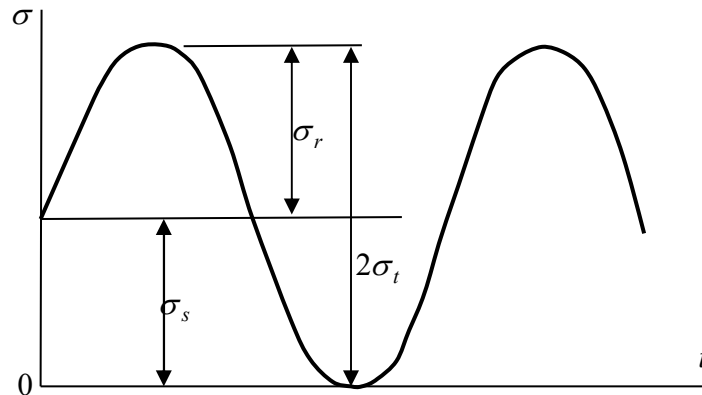

Figure 80 : repeated stress

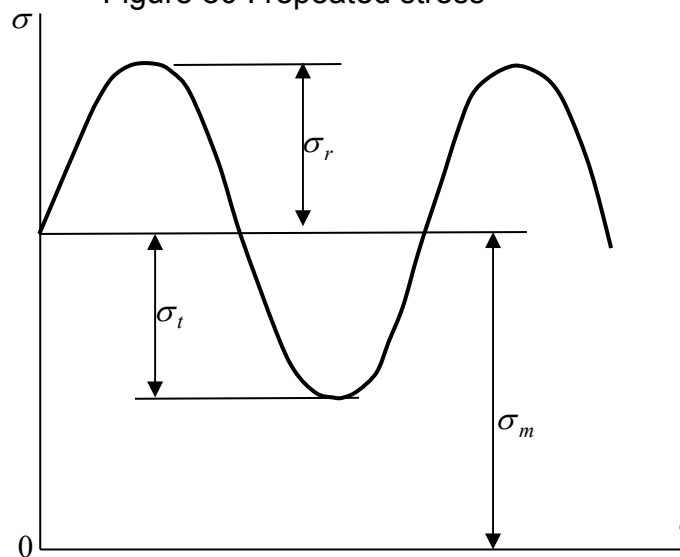

Figure 81 : combined steady and alternating stress

For alternating stress, the stress varies from  $\sigma_r$  compressive to  $\sigma_r$  tensile. Whereas, the repeated stress varies from zero to a maximum tensile or compressive stress, of magnitude  $2\sigma_r$  and the combined of both have an average value ( $\sigma_m$ ) with a superimposed alternating stress of range  $\sigma_r$ .

<b>International Association Of Certified Practicing Engineers</b>	<b>ENGINEERING MATERIALS AND THEIR STRENGTH</b>	<b>Page 144 of 151</b>
		<b>Rev: 02</b>
	<b>CPE LEVEL I TRAINING MODULE</b>	<b>Jan 2015</b>

### a. SN Curves – Endurance Limit

Determining the endurance limit could be applied by doing a test specimens that are subjected to a very large number of stress reversals. The number of cycles  $N$  of alternating stress to cause failure and the magnitude of the stress  $\sigma_f$  are plotted. At  $N = 0$ , failure occurs at  $\sigma_u$ , the ultimate tensile strength. At lower stress  $\sigma_e$  or known as the endurance limit, failure occurs, in the case of steel, as  $N$  approaches infinity, however, in the case of non-ferrous metals, alloys and plastics, the curve does not flatten out and a fatigue stress ( $\sigma_{FS}$ ) for a finite number of stress reversals  $N'$  is specified as shown in Figure 82<sup>[10]</sup>.

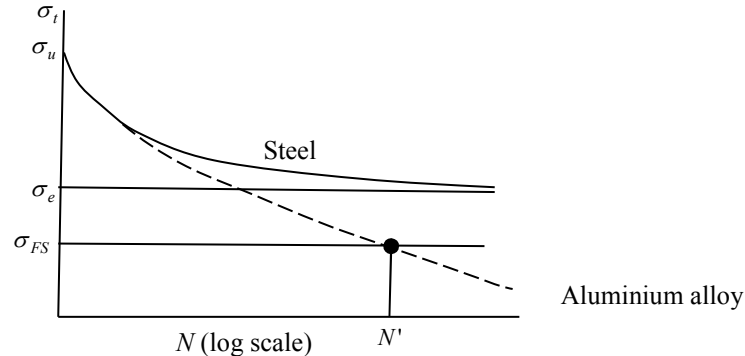

Figure 82 : endurance limit curve

### b. Endurance Limit and Fatigue Stress for Various Materials

#### i. Steels, Non-ferrous metals, and Alloys

Most steels have an endurance limit which is about half of its tensile strength. An approximation often used is described as follows :

- Endurance limit = 0.5x tensile strength, up to a tensile strength of 1400 N/mm<sup>2</sup>.
- Endurance limit = 700 N/mm<sup>2</sup> above a tensile strength of 1400 N/mm<sup>2</sup>.

For cast iron and cast steel, the endurance limit follows the rules as approximately :

- Endurance limit = 0.45 x tensile strength up to a tensile strength of 600 N/mm<sup>2</sup>.
- Endurance limit = 275 N/mm<sup>2</sup> above a tensile strength of 600 N/mm<sup>2</sup>.

In the special case of non-ferrous metals and alloys, there is no endurance limit and the fatigue stress is taken at a definite value of stress reversals, e.g 5 x 10<sup>7</sup>.

<b>International Association Of Certified Practicing Engineers</b>	<b>ENGINEERING MATERIALS AND THEIR STRENGTH</b>	Page 145 of 151
		Rev: 02
		Jan 2015
<b>CPE LEVEL I TRAINING MODULE</b>		

Some typical values are given in the Table 27 and Table 28.

Table 27 : endurance limit for some steels

Steel	Condition	Tensile strength, $\sigma_u$ (N/mm <sup>2</sup> )	Endurance limit, $\sigma_e$ (N/mm <sup>2</sup> )	$\sigma_e / \sigma_u$
<b>0.4% Carbon (080M40)</b>	Normalized, Hardened and tempered.	540	270	0.50
		700	340	0.49
<b>Carbon, Manganese (150M19)</b>	Normalized, Hardened and tempered.	540	250	0.46
		700	325	0.53
<b>3% Chrome molybdenum (709M40)</b>	Hardened and tempered.	1000	480	0.48
<b>Spring steel (73A50)</b>	Hardened and tempered.	1500	650	0.43
<b>18,8 Stainless</b>	Cold rolled	1200	490	0.41

Table 28 : wrought aluminium alloys

Material	Tensile strength, $\sigma_u$ (N/mm <sup>2</sup> )	Fatigue stress, $\sigma_{FS}$ (N/mm <sup>2</sup> ), ( $5 \times 10^7$ cycles)	$\sigma_u / \sigma_{FS}$
<b>N3 non-heat-treated</b>	110	48	0.44
	130	55	0.42
	175	70	0.40
<b>H9 heat treated</b>	155	80	0.52
	240	85	0.35

The values of endurance limits and fatigue stress in Table 29 are based on tests on highly polished small specimens. For other types of surface the endurance limit must be multiplied by a suitable factor which varies with tensile strength. Values are given for a tensile strength of 1400 N/mm<sup>2</sup>. The values are also factored which depend upon size, temperature, etc.

Table 29 : effect of surface finish

Surface	Surface factor
Polished	1.0
Ground	0.90
Machined, cold drawn	0.65
Hot rolled	0.37
As-forged	0.25

### c. Causes of Fatigue Failure in Welds

Under fatigue loading, discontinuities lead to stress concentration and possible failure. Great care must be taken in welds subject to fluctuating loads to prevent unnecessary stress concentration. Figure 83 is cause of the fatigue failure and figure 84 is illustration of preferred welds.

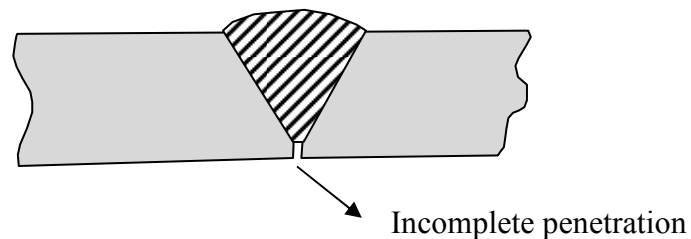

Figure 83 : example of incomplete penetration

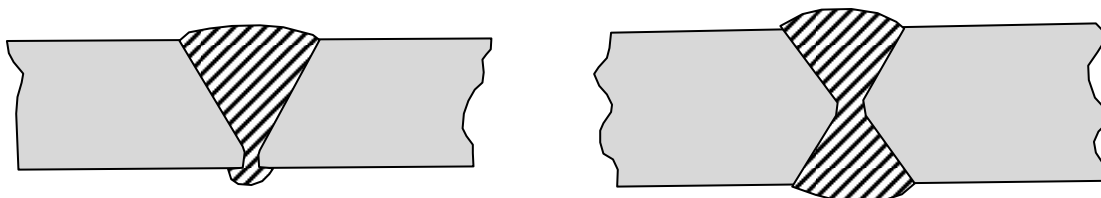

Figure 84 : example of preferred welds

<b>International Association Of Certified Practicing Engineers</b>	<b>ENGINEERING MATERIALS AND THEIR STRENGTH</b>	<b>Page 147 of 151</b>
	<b>CPE LEVEL I TRAINING MODULE</b>	<b>Rev: 02</b>
		<b>Jan 2015</b>

#### i. Stress Concentration factor (K)

At a discontinuity like a notch, hole or step, the stress is much higher than the average value by a factor K, which is known as the 'stress concentration factor'. The stress concentration factor could be seen that for a 'wide plate' with a hole the highest stress is times the nominal stress. Higher stresses will also occur if the cross section of the member undergoes a sudden change (critical cross section). Stress concentration factor is formulated as<sup>[10]</sup> :

$$K = \frac{\text{Highest value of stress at discontinuity}}{\text{Nominal stress at the minimum cross - section}} \quad \text{Eq (109)}$$

or<sup>[3]</sup>

$$K = \frac{\sigma_{\max}}{\frac{Mc}{I}} \quad \text{Eq (110)}$$

#### d. Safety Factor for Failure Event

If structural failure is to be avoided, the loads that a structure is capable of supporting must be greater than the loads it will be subjected to when in service. Since strength is the ability of a structure to resist loads, the preceding criterion can be restated as follows: "the actual strength of a structure must exceed the required strength". The ratio of the actual strength to the required strength is called the factor of safety,  $n$  that is given as

$$n = \frac{\text{actual strength}}{\text{required strength}} \quad \text{Eq (111)}$$

The factor of safety must be greater than 1.0 if failure is to be avoided. Depending upon the circumstances, factors of safety from slightly above 1.0 to as much as 10 are used<sup>[12]</sup>.

## H. Hardness

As described in general consideration, hardness is the resistance of a material to penetration by a pointed tool. There are many hardness-measuring systems. The Brinell hardness is one of tests in very general use. Brinell hardness is determined by forcing a hardened sphere under a load into the surface of material and measuring the diameter of the indentation left after the test. The Brinell hardness number, or simplified as The Brinell number, is achieved by dividing the load used, in kilograms, by the actual surface area of

<b>International Association Of Certified Practicing Engineers</b>	<b>ENGINEERING MATERIALS AND THEIR STRENGTH</b>	<b>Page 148 of 151</b>
		<b>Rev: 02</b>
		<b>Jan 2015</b>
<b>CPE LEVEL I TRAINING MODULE</b>		

the indentation, in square millimeters. The result is a pressure, but the units are rarely stated.

$$BHN = \frac{P}{\left[ \frac{\pi D}{2} \left( D - \sqrt{D^2 - d^2} \right) \right]} \quad \text{Eq (112)}$$

Where,

- P : Imposed Load, lb (kg)
- D : Diameter of the spherical indenter, in (mm)
- d : Diameter of the resulting impression, in (mm)

<b>International Association Of Certified Practicing Engineers</b>	<b>ENGINEERING MATERIALS AND THEIR STRENGTH</b>	Page 149 of 151
		Rev: 02
		Jan 2015

## REFERENCES

1. Ashby, Michael F., *Material Selection in Mechanical Design, 3th Ed.* Butterworth Heinemann : Oxford, 2005.
2. Avallone, Eugene A., Baumeister III, Theodore. *Marks' Standard handbook for Mechanical Engineers.* McGraw-Hill : New York, 1996.
3. Beer, F. P et Al., *Mechanics of Materials, 6<sup>th</sup> Ed.* Mc. Graw Hill Companies, Inc. : New York, 2012.
4. Billmeyer, F. W., Jr., *Textbook of Polymer Science, 3<sup>rd</sup> Ed.* John Willey & Sons, Inc. : New York, 1984.
5. Brady, George S., Clauser, Henry R., Vaccari, John A. *Materials Handbook Fifteenth Edition.* McGraw-Hill : New York, 2006.
6. Budynas, Nisbett, *Mechanical Engineering, 8<sup>th</sup> Ed.* Mc. Graw Hill Companies, Inc. : New York, 2006.
7. Callister, William D, Jr., *Materials Science and Engineering-An Introduction, 7<sup>th</sup> Ed.* John Willey & Sons, Inc. : New York, 2007.
8. Carraher, Charles E., Jr., *Polymer Chemistry, 6<sup>th</sup> Ed.* Marcel Dekker, Inc. : New York, 2005.
9. Carter, C. Barry., Norton, M. Grant. *Ceramic Materials Science and Engineering.* Springer, 2007.
10. Carvill, James. *Mechanical Engineer's Data Handbook.* Butterworth Heinemann : Oxford, 2003.
11. Gaskell, David R. *Introduction to the Thermodynamics of Materials, Fourth Edition.* Taylor and Francis, Inc., 2003.
12. Gere, James M., *Mechanics of Materials, 6<sup>th</sup> Ed.* Thomson Learning, Inc. : USA, 2004.
13. Harper, Charles A., Petrie, Edward M. *Plastics Materials and Processes : A Concise Encyclopedia.* John Wiley & Sons, Inc., Publication : Hoboken – New Jersey, 2003.

<b>International Association Of Certified Practicing Engineers</b>	<b>ENGINEERING MATERIALS AND THEIR STRENGTH</b>	Page 150 of 151
		Rev: 02
		Jan 2015

14. Huyett, G.L., *Engineering Handbook*. Industry Press, Inc. : New York, 2000.
15. Irwin, J. David. *Mechanical Engineer's Handbook*. Academic Press : California, 2001.
16. Kailas, Satish V., *Application and Processing of Ceramics*. Dept. of Mechanical Engineering : Bangalore, India.
17. Kailas, Satish V., *Applications and Processing of Metals and Alloys*. Dept. of Mechanical Engineering : Bangalore, India.
18. Kailas, Satish V., *Composites*. Dept. of Mechanical Engineering : Bangalore, India.
19. Mitchell, Brian S. *An Introduction Materials Engineering and Science For Chemical and Materials Engineers*. John Wiley & Sons, Inc. : Hoboken – New Jersey, 2004.
20. Rajput, R. K., *A Textbook of Applied Mechanics, 3<sup>rd</sup> Ed.* Laxmi Publications Ltd : New Delhi, 2011.
21. Sandor B.I., Roloff, R, et al., *Mechanical Engineering Handbook, "Mechanics of Solids"*. CRC Press LLC. 1999.
22. Smith, Edward. H. *Mechanical Engineer's Reference Book*. Butterworth Heinemann : Oxford, 2000.
23. Sōmiya, S., Aldinger, F., Claussen, N., Springgs, R. M., Uchimo, K., Kuomoto, K., Kaneno, M. *Handbook of Advanced Ceramics*. Elsevier Ltd : California, 2003.
24. <http://www.aagarsen.com/>
25. <http://ceramics.org/learn-about-ceramics/structure-and-properties-of-ceramics>
26. [www.chemistry-assignment.com/59-2-classification-of-polymers](http://www.chemistry-assignment.com/59-2-classification-of-polymers)
27. [https://ecourses.ou.edu/cgi-bin/ebook.cgi?doc=&topic=me&chap\\_sec=03.1&page=theory](https://ecourses.ou.edu/cgi-bin/ebook.cgi?doc=&topic=me&chap_sec=03.1&page=theory)
28. [www.eng.utoledo.edu/~tschrede/met1110/Unit%206.pdf](http://www.eng.utoledo.edu/~tschrede/met1110/Unit%206.pdf)
29. <http://faculty.uscupstate.edu/llever/Polymer%20Resources/Classification.htm#thermosets>

<b>International Association Of Certified Practicing Engineers</b>	<b>ENGINEERING MATERIALS AND THEIR STRENGTH</b>	<b>Page 151 of 151</b>
		<b>Rev: 02</b>
		<b>Jan 2015</b>

30. <https://faculty.unlv.edu/jagadeep/ME302/Some%20Guidelines%20for%20Constructing%20Shear%20Force%20and%20Bending%20Moment%20Diagrams.pdf>