

ENGINEERING PRACTICE

VOLUME 1 NUMBER 1

APRIL 2015

SPECIAL FEATURE
PROPYLENE TOWER DESIGN

IACPE
INTERNATIONAL ASSOCIATION OF
CERTIFIED PRACTICING ENGINEERS

EXPAND YOUR HORIZONS
WWW.IACPE.COM

**ENGINEERING
PRACTICE**VOLUME 1
NUMBER 1

APRIL 2015

ACADEMIC BOARD**Dr. Dominic Foo**
Dr. Sivakumar
Kumaresan**INDUSTRY BOARD****Helmilus Moesa**
Supriyanto
Timothy M. Zygula**LEADERSHIP BOARD****Karl Kolmetz**
William B. Lotz
Lin L. Choo**ABOUT**

International Association of Certified Practicing Engineers provides a standard of professional competence and ethics. Identifies and recognizes those individuals that have meet the standard. And requires our members to participate in continuing education programs for personal and professional development.

In addition to insuring a professional level of competency and ethics the IACPE focuses on three major areas of development for our members: Personal, Professional, and Networking.

HISTORY

The **International Association of Certified Practicing Engineers** concept was formulated by the many young professionals and students we meet during our careers working in the field, running training courses, and lecturing at universities.

During question and answer sessions we found the single most common question was: What else can I do to further my career?

We found, depending on the persons available time and finances, and very often dependent on the country in which the person was from, the options to further ones career were not equal.

Many times we found the options available to our students in developing countries were too costly and or provided too little of value in an expanding global business environment.

The reality is that most of our founders come from countries that require rigorous academic standards at four year universities in order to achieve an engineering degree. Then, after obtaining this degree, they complete even stricter government and state examinations to obtain their professional licenses in order to join professional organizations. They have been afforded the opportunity to continue their personal and professional development with many affordable schools, programs, and professional organizations. The IACPE did not see those same opportunities for everyone in every country.

So we set out to design and build an association dedicated to supporting those engineers in developing in emerging economies.

The IACPE took input from industry leaders, academic professors, and students from Indonesia, Malaysia, and the Philippines. The goal was to build an organization that would validate a candidates engineering fundamentals, prove their individuals skills, and enhance their networking ability. We wanted to do this in a way that was cost effective, time conscience, and utilized the latest technologies.

MISSION

Based on engineering first principles and practical real world applications our curriculum has been vetted by academic and industry professionals. Through rigorous study and examination, candidates are able to prove their knowledge and experience. This body of certified professionals

engineers will become a network of industry professionals leading continuous improvement and education with improved ethics.

VISION

To become a globally recognized association for certification of professional engineers.

WWW.IACPE.COM | INFO@IACPE.COM
KNOWLEDGE. CERTIFICATION. NETWORKING.

LETTER FROM THE PRESIDENT

KARL KOLMETZ



EXPAND YOUR HORIZONS

I hope you are doing great. My wish is that you find a career that you enjoy and then reap the benefits from your hard work. The only place that success comes before work is in the dictionary. The most successful people are those that work smart and work hard.

I have been very fortunate to be able to work all over the world. My horizon has been expanded by the new cultures and the great people that I have met in my career. Sometime life will try to put you in a small box, and say this is all you are capable of achieving. Every time someone or something has tried to put me in a small box I have resisted and obtained freedom from the career small box by gaining knowledge. Knowledge is the power by which you will expand your horizon and opportunities.

The IACPE program has three fundamental parts, which are Education, Certification and Networking.

The first part is Education. Education and knowledge are the basic building blocks for success. It is critical for you to gain knowledge, so you can work smart and free yourself from a small box. The IACPE Training Modules are designed to develop you into a well rounded fundamentally strong engineer that understands your chosen engineering discipline and other engineering disciplines including: civil, chemical, environmental, industrial, and mechanical. At some point in your career you will work with each of these disciplines and your broad based knowledge will assist you in your projects.

The second part is IACPE Certification. An honest career mentor will advise you to obtain multiple degrees and multiple certifications. If you already have an engineering degree, a good next degree might be a Masters in Engineering or a Masters in Business. If it is possible to obtain a Professional Engineer Certification from your country this would be a good certification to obtain. We also believe that an international certification, like IACPE, would be a worthwhile certification to obtain. For your career multiple degrees and multiple certifications will lead to more opportunities.

The third part is Networking. Your best career opportunities will come from people that know you and your capabilities. IACPE has built a network of engineers all over the world, which will help you to gain knowledge, be tested on the knowledge learned, and become certified to further your career. This network of certified engineers will open doors for your career that would otherwise be difficult to find.

IACPE will host networking and technical topic meetings that you may attend similar to the one held in April 2015 in Indonesia. The networking meeting will have a networking social followed by a technical topic by a leading industry professional. Helmilus Moesa, a member of IACPE's Industry Board, gave a great technical presentation on Process Plant Optimization in our April 2015 Networking Technical Topic Meeting.

You will never be truly happy living in a small box, when you know you are capable of accomplishing greater things. Expand your horizons by Education, Certification and Networking.

All the Best in Your Career,

Karl

NEWS

IACPE QUARTERLY MEETING

On April 7th, 2015 IACPE had a great quarterly meeting at the Center of Excellence (COE) building in Cilegon, Indonesia. We presented a special industrial guest speaker Mr. Helmilus Moesa, General Manager of Chandra Asri and IACPE Industry Board member, who spoke about Process Plant Optimization. Mr. Supriyanto, Production Planning General Manager of Chandra Asri and IACPE Industry Board member, also attended the meeting.

We also met with the people from the Industrial company, such as PT. Sulfindo.

IACPE members also attended this meeting. We awarded 23 certificates for Certified Process Engineer - Engineer in Training (CPE-EIT).



CPE-EIT RECIPIENTS

Apriliana Dwijayanti
 Reni Mutiara Sari
 Hery Purnama
 Rievan Putra
 Yulius Sandy
 Khumaedi Muharom
 Mela Widiawati
 Riska Ristanti
 Evieta Prameswari Rendini
 Naimi
 Latifah Upe Suprianto
 Iqbal Pratama Malik
 Indra Budi Setiawan
 Ruly Octora
 Webi Andriansyah
 Ryka Usnilawaty
 Nasihin
 Vivi Kurniawati
 Tarsono
 Wahyu Dianing Tiyas
 Ayu Zakiyah
 Amalia Rahmawaty
 Jahrotun Uyun



Visit www.IACPE.com for information on the next meeting.

SUMMIT Technology Management is a technical consultancy group, providing specialized services and equipment to improve process plant operational efficiency, profitability and safety. We provide practical solutions by offering training, technical services, best practices, engineering, and equipment to meet the specific needs of our partner clients.

Basic Design Packages

Detailed Design Packages

Commissioning of Process Units

Process Engineering Studies

Bench marking of Process Units

**Regional Training Conferences and
In House Training**

**Singapore and Malaysia Company
Registration and Set Up**

Specialty Equipment

- 1. Distillation Equipment**
- 2. Filter Skid Packages**
- 3. Compressor Knock Out / Scrubber Skid Packages**
- 4. Mercury Removal Skid Packages**



Partners to the Top



SUMMIT
Technology Management
(JM680605-W)

Contact Us

P. O. Box 281, Pejabat POS Bandar Johor Bahru,
80000 Johor Bahru, Johor, Malaysia
Office No.: +(60) 12 710 9012 Fax No.: +(60) 7 2070 252
Email: info@summit-tech-mtg.com

CAREER GUIDELINES



IACPE President Karl Kolmetz speaking to students of LP3I Cilegon, Indonesia.

IACPE President Karl Kolmetz hosted a great program on April 8th, 2015 at LP3I Cilegon, Indonesia. He met numerous eager students to give them motivation about their future careers.

Twenty-six LP3I Cilegon students attended this motivational class. and were very enthusiastic for this program. Mr. Kolmetz talked about self motivation and introduced IACPE.

At the end students were allowed a Q&A with Mr. Kolmetz. One of the questions asked by the students was "How can I be a great engineer at my company?" to which Mr. Kolmetz answered that "one of the ways to be a great engineer [at your company] is

HARDWORK and being HONEST."

The meeting culminated with 26 students being awarded certificates.

Why should you become IACPE certified?

- Be able to compete with graduate from other universities
- To connect with industrial experts who can help you to further your career
- Gains a valuable career
- Attain abilities recognized across the industry
- Align your knowledge to industry competency standards
- Supporting engineers in developing in emerging economics

Become certified in the following engineering disciplines: Mechanical, Metallurgical, Chemical, Electrical, Civil, and Industrial.

Students will receive: Five Engineering Modules, Five Engineering Study Questions Modules, Five Engineering Test Modules, Certificate, and CPE I Title.

WWW.IACPE.COM



GUIDELINES FOR PROPYLENE SPLITTERS

By

Timothy M. Zygula, Port Arthur, TX

Karl Kolmetz, KLM Technology Group, Johor Bahru, Malaysia



INTRODUCTION

The Chemical Processing Industry has been continually pushing the capacity envelope of new and existing distillation columns. While increasing the capacity of existing columns is not unusual, great care needs to be taken when a revamp is being considered. There is a fine line between success and failure when a column is designed at or near the upper end of the capacity envelope.

The authors will detail the methodology used when designing a new or considering a capacity increase for an existing propylene splitter.

This paper will discuss design aspects that need to be considered when designing a propylene splitter.

The authors will also present a generic case study of a

propylene splitter revamp.

Some of the topics that will be covered by the authors are:

1. Process simulation of a propylene splitter – proper simulation techniques
2. From the simulation to the field – tray efficiencies
3. Utilizing a process simulation to develop column hydraulics
4. The types of internals that have been used in propylene splitter columns
5. Design considerations that need to be addressed when considering a revamp.

The image features a header with the KLM logo in red and 'Technology Group' in blue. A red banner to the right contains the text 'Engineering solutions, Standards, and Software'. The background is a faded industrial scene with a tall distillation column. A purple vertical bar is on the left side of the page.

KLM

**Technology
Group**

Engineering solutions, Standards, and Software

KLM Technology Group is a technical consultancy group, providing specialized services and training to improve process plant operational efficiency, profitability and safety.

We provide engineering solutions by offering training, technical services, best practices, and engineering designs to meet the specific needs of our partner clients.

Since 1997, KLM Technology Group has been providing engineering, operations, and maintenance support for the hydrocarbon processing industry.

What KLM Technology Group does:

- 1) Specialized technical articles and books,
- 2) Detailed Engineering Design Guidelines,
- 3) Project Engineering Standards and Specifications,
- 4) Typical Process Unit Operating Manuals,
- 5) Training Videos,

WWW.KLMTECHGROUP.COM

General Design of Distillation Column

Separations are a major part of the chemical processing industry. It has been estimated that the capital investment in separation equipment is 40-50% of the total for a conventional fluid processing unit. In a plant one of the main unit operations is material separation. This includes distillation, storage tanks, flash drums and other equipment of this nature. Of the total energy consumption of an average plant, the separation process accounts for about 50% to 70% of the energy consumption of the plant. Within that area of the material separation, the distillation unit operation method accounts for normally greater than 80% of the energy consumed for this process.

In general, initial design of a distillation tower involves specifying the separation of a feed of known composition and temperature. Constraints require a minimum acceptable purity of the overhead and the bottoms products. The desired separation can be achieved with relatively low energy requirements by using a large number of trays, thus incurring larger capital costs with the reflux ratio at its minimum value. On the other hand, by increasing the reflux ratio, the overhead composition specification can be met by a fewer number of trays but with higher energy costs.

Design of a Propylene Splitter

Determining the design of a Propylene Splitter requires an understanding of the simulation model used to generate the internal loads and physical properties, vapor and liquid equilibrium data utilized, tray hydraulics, and how the selection of the internals will affect the actual efficiency of the installed equipment in the field.

The typical design of a propylene splitter is not complex and there are two general variations in design. The first is a called high-pressure system, and the second is called a heat pumped system. A high-pressure system is designed to utilize cooling water as the source to cool the overhead vapor, and a high

pressure is needed to condense the propylene vapor at ambient temperatures of about 40 degrees C.

A heat pump system utilizes a compressor to reduce the tower pressure to allow the distillation column to be smaller. In most distillation application, relative volatilities can be improved by lowering the pressure. This results in lower number of stages required and reflux ratios, but at the cost of higher energy requirements of the compressor.

A good rule of thumb is that if the propylene system is associated with an ethylene plant, in which there is typically an abundance of quench water that can be used to heat the C3 Splitter reboiler a non heat pump system may be the best choice. If no source of sufficient low-

grade heat is available for example in a refinery FCC unit or propane dehydrogenation unit, then the use of a Heat Pump is typically the economical choice.

HIGH PRESSURE SYSTEM

FIGURE 1

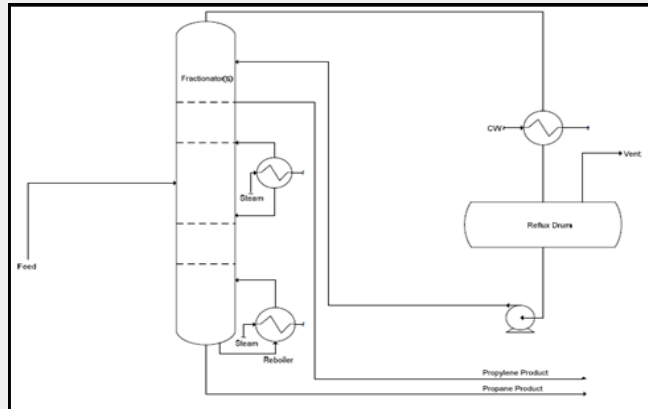

The first is a called a high-pressure system, and the second is called a heat pumped system.

A high-pressure system is designed to utilize cooling water as the source to cool the overhead vapor, and a high-pressure system is needed to condense the propylene vapor at ambient temperatures of about 40 degrees C.

HEAT PUMPED SYSTEM

FIGURE 2

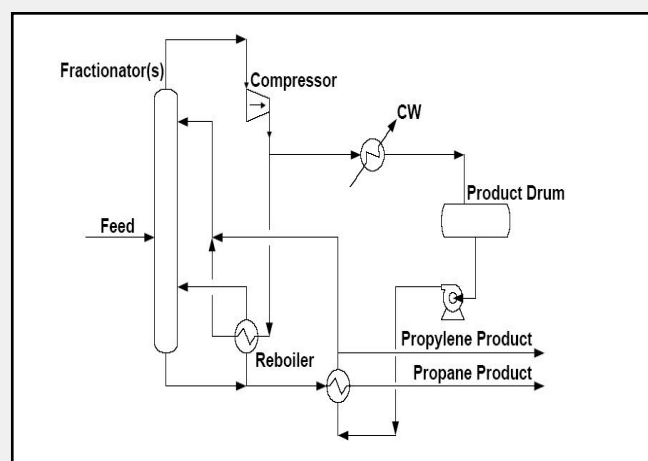

A heat pump system utilizes a compressor to reduce the tower pressure to allow the distillation column to be smaller. In most distillation applications relative volatilities can be improved by lowering the column pressure. This results in lower number of required theoretical stages and reflux flow. These savings are offset by the required energy cost of the compressor.

Process Simulation of a Propylene Splitter – Proper Simulation Techniques

Simulation of a propylene splitter seems very simple and can be done quickly by

3rd year engineering students. There are a small number of components and the equipment layout is not complex. The challenge of a propylene splitter is that, unless you use the correct vapor and liquid equilibrium data, the simulation can have greater than 15% inaccuracies as compared to actual field data.

Physical properties are critical to the success of a simulation model and are also very important to the accuracy of the model. Poor physical property data may prevent your simulation model from converging. The most typical problem is missing parameters in the thermodynamic package utilized. This is not unusual in most commercial simulation packages.

Physical property parameters for most compounds are not known for every thermodynamic model at every pressure and temperature range. Many times this fact is overlooked when a design model is constructed. Simulation models are constructed and executed with thermodynamic parameters missing. Although the model may appear to be correct but may be incorrect because of the missing thermodynamic data. Then there is the problem that all of the thermodynamic data are present but the data are not accurate. This problem is even worse than the problem of missing data since the results from the simulation model will appear to be correct, but are totally wrong. Most simulation packages won't alert the users that there is a problem. It is the job of the user to determine if the results from a simulation model are accurate (1).

The best way to confirm if your thermodynamic data are correct is to see if you can find any laboratory data or data from literature on your system. This may not always be practical because good thermodynamic test data are hard to find.

Sometimes that data may have to be generated in a pilot plant before any design work begins.

Research the system being modeled. Published thermodynamic data on the system being modeled may exist. If data is obtained, the data must cover the same temperature and pressure range that you are designing. Next, run a simulation with the same system and see if you can match the data. Most data on propylene splitters has been compiled from years of operating experience. Many companies that license technology have done extensive testing and have developed propylene splitter data for design purposes.

The most accurate Vapor Liquid Equilibrium (VLE) data

for Propylene Splitters might be Ping Robinson, but there is a huge data base of distillation columns designed and built utilizing Soave Redlich Kwong (SRK), and many designers utilize SRK to be able to utilize the existing data-base for actual tray efficiency in the field. The standard SRK equation of state model handles the propane / propylene binary K values adequately over the typical operating pressure range of these towers, which is 5 bar (100 psia) to 20 bar (320 psia). The other miscellaneous lights, heavies and intermediate boilers, such as Propadiene (PD), methyl-acetylene (MA or propylene), ethane and iso-butane, are also adequately modeled using the SRK equation of state. (3)

Methyl-acetylene (MA) is an intermediate boiler that is lighter than propane and heavier than propylene. Even at small ppm concentrations in the feed will, over time, result in a build up of MA in the tower. Concentrations inside C3 Splitter towers 10 to 20 trays from the bottom can be as high as 15% to 20% depending on the severity of propylene recovery required. Many propylene splitter systems have a sample point in this 10 to 20 tray range from the bottom to be able to sample the MA concentration in the column. MA, being a triple bonded hydrocarbon at elevated concentrations, above 40%, can auto decompose with potential adverse consequences. Propadiene (PD) is heavier than both propane and propylene and will never have a significant concentration in the overhead product.

Many choices are available for enthalpy models in simulation packages. SRK will do an adequate job but there may be better choices. This is important because there are always light components (i.e. methane, ethylene) that will be present in the feed and they will be close to their critical temperature. The choice of enthalpy model will help in the tower consistently achieving convergence. (3)

One other area of concern is the specific heat of liquid propylene. Some Propylene Splitters will have sub-cooled reflux return or a sub-cooled feed. The performance of a C3 Splitter tower is heavily dependent on a proper heat balance on the tower. Sub-cooled streams have to be accounted for properly. Propylene pure component liquid specific heat data is quite varied. The variation in reputable data has an error band of over 15%.

There are many choices in the vapor density, enthalpy, specific heat, viscosity, and surface tension model correlations. It is important to be able to tune your model to actual field data so that your model will reflect the real world.

High Pressure:

High-pressure distillation in a column can have challenges. There are many factors to be considered when designing at high operating pressures. (1).

At higher operating pressures the relative volatility of the system is lower which increases the separation difficulty. As a direct result of increased separation difficulty the reflux requirements for the column would increase. The column would also require more stages and increased duties for the reboiler and condenser to perform the separation. Propylene Fractionators are high liquid traffic columns that require internals that can handle high liquid traffic.

At higher operating pressures the reboiler temperature rises, thereby requiring a more expensive heating medium. If the same heating medium is used a reboiler with a larger heat transfer area would be required.

At high operating pressures the vapor density would increase and therefore lower the required vapor handling capacity. This would lead to a reduction in the diameter of the column, which would reduce the capital equipment costs.

High Pressure Distillation Tray/Column Design:

As the distillation pressure is increased, the vapor density increases. When the critical pressure is approached, the compressibility factor of a saturated vapor usually has a value less than 0.75. Thus the vapor density of the gas phase is quite high at pressures greater than 40% of critical. As the operating pressure is increased for the same C_s (Capacity Factor) value, the vapor mass flow rate will be much greater than at atmospheric operating pressure because of the high vapor density. While at the same time the liquid mass flow rate will be greater at high operating pressure than at atmospheric operating pressure. Therefore, liquid flow rates per unit of column cross-sectional area will be higher as operating pressure increases. The capacity of the fractionating device at high pressure may be dependent on its ability to handle these high liquid flow rates.

In a propylene fractionator column, the tower cross sectional area is the sum of the trays active area plus the total downcomer area. .

The amount of required active area (Vapor-Liquid Bubbling Area) is determined by vapor flow rate. The downcomers handle a mixture of clear liquid, froth, and aerated liquid. The downcomer area required to handle the high liquid flow not only increases with the liquid flow rate, but also with the

difficulty in achieving separation between the liquid and vapor phases. The volume required for the downcomer increases at a lower surface and a smaller density difference between the liquid and vapor. Because of the large downcomer area required to handle the high liquid flow rates the area may be 40% to 80% greater than the calculated tray active area for the vapor flow rates for propylene fractionator distillation. The downcomer area becomes a significant factor in the determination of the tower diameter.

Simulation Accuracy:

In order to determine the accuracy of a simulation it is always desirable to construct a McCabe-Thiele diagram from the data generated from the simulation. The data from the simulation can be easily transferred to a software package where the graph can be constructed. This graph is used more as a tool to identify possible problems that won't be discovered until the column fails. The following is a list of the areas where a McCabe-Thiele diagram can be used as a powerful analysis tool (1).

pinched regions - Pinching is readily seen on an x-y diagram.

Mislocated feed points - the feed point should be where the q-line intersects the equilibrium curve. This is generally the rule in binary distillation. However, it is not always true in multicomponent distillation. A key ratio plot is often developed in the design phase. This type of plot is far superior to an x-y diagram for identifying mislocated feeds, especially with large multicomponent systems.

Determining if the column is being over refluxed or reboiled - this can be recognized by too wide of a gap between the component balance line and the equilibrium curve throughout the column.

Identify cases where feed or intermediate heat exchangers are needed.

Most commercial simulation programs will provide the information required to generate these plots.

Column Sizing

Once the internal liquid and vapor traffic is obtained from the simulation model, the diameter of the column must be obtained. Most simulation packages have tower-sizing routine. These routines are fairly easy to use and yield quick results. However, these results should be verified by calculation.

Column sizing is done on a trial and error basis. The first step is to set the design limits. The design limits are as follows:

1. Maximum Design rates – Vapor/Liquid Traffic is needed at Maximum Operating rates.
2. Design rates - Vapor/Liquid Traffic is needed at Design Operating Conditions.
3. Minimum Design rates - Vapor/Liquid Traffic is needed at Minimum Operating rates.

Sizing calculations need to be performed in areas of the column where the vapor/liquid traffic is expected to be highest and lowest for each section.

For example,

- The top tray and bottom tray in the column
- The feed tray
- Any product draw-off tray or heat addition/removal tray.
- Tray where the vapor liquid loading peaks.

There are also shortcut methods to sizing a column, which involve using a flooding correlation. These methods minimize the amount of trial and error calculations. Using the method as outlined by Kister (2) the first step is to determine the C-Factor at the most heavily loaded point in the column. Using an entrainment flooding correlation like the Kister and Haas correlation the C-Factor at flood can be calculated.

$CSB = 0.144 [d2H s/rL]^{0.125} [rG rL]^{0.1} [S/ hct]^{0.5}$ – Kister and Haas (2)

Next the vapor velocity at flood based on net column area minus the tray downcomer area needs to be calculated. This calculation is done for the top and bottom section of the column (2).

$uN = CSB [(rL - rV)/ rV]^{(1/2)}$ – Flooding Vapor Velocity, ft/s

Next, the bubbling area required for the top and bottom sections of the column need to be calculated using equation 3. In new designs columns should be design for 80% flood (2).

$3. AN = CFS / [(SF)(0.8)uN]$ – Bubbling Area Required (Column Cross Sectional Area less downcomer top area, ft²)

Next, the downcomer top area needs to be calculated using equation 4. This calculation is done for the top and bottom section of the column (2).

$AD = GPM / VDdsg$ – Downcomer Area.

Once this has been completed the tower cross sectional area can be calculated using equation 5. The tower diameter can be calculated from the tower area. (2).

5. $AT = AN + AD$ – Tower Cross Sectional Area, ft²

The following are the definitions of the parameters used in the above equations.

CSB – C-Factor at flood, ft/s

dH – Hole Diameter, in

S – Tray Spacing, in

hct - Clear liquid height at the transition from the froth to spray regime, in of Liq

rG, rL – Vapor and Liquid Density, lb/ft³

s - Surface Tension, Dyne/cm

SF – Derating Factor or Foaming Factor

GPM – Tray Liquid Loading, GPM

VDdsg – Downcomer, GPM/ft²

AN – Tray Bubbling Area, ft²

AD – Downcomer Top Area, ft²

AT – Total Tower Cross Sectional Area, ft²

Column Internal Design

Once the preliminary tower diameter has been set the internals can be chosen. The task of choosing the type of tower internal to use is very important. The type of column internals used dictates a column's efficiency and capacity. All of the modeling and careful design work will mean nothing if the wrong type of column internals is chosen. For propylene fractionation trays are the only type of internal that should be considered.

The types of internals that have been used in propylene splitter columns are:

- Conventional Cross Flowing Trays
- Counter Contacting Trays
- Structured Packing
- High Capacity Trays
- Multiple Downcomer Trays

Conventional Multipass Trays

Conventional Multipass trays are typically used when a column is initially designed. Four pass or six pass trays are usually used because of their ability to handle high liquid loads like seen in propylene fractionation. The downside to using multipass trays is the reduction in separation efficiency that is experienced due to the reduction in active area. Great care must be taken when sizing downcomers in high-pressure distillation applications. The difference between vapor and liquid densities becomes smaller and separation of vapor from liquid in a downcomer becomes more difficult. This can result in increased aeration back-up and possible premature downcomer flooding. (2)

Multi-Downcomer Trays:

Multi-Downcomer trays are used for large liquid loads, particularly when the volumetric ratio between vapor and liquid rates is low. These situations occur in medium to high-pressure distillation, in absorption and stripping, and in direct contact heat transfer applications.

Multi-Downcomer trays can be used at close tray spacing. This will allow a reduction in both height and diameter of a new column compared to a column fitted with conventional multi-pass trays. Vessel shell costs can be significantly reduced with the use of Multi-Downcomer trays. When retrofitting an existing column with Multi-Downcomer trays, a significantly greater number can be installed, providing increased product purities and recoveries, as well as reduced reflux ratio for reduced energy consumption and/or increased column capacity.

The use of Multi-Downcomer trays has often reduced the number of columns needed in difficult separations, such as the fractionation of propylene-propane.

Tray Efficiencies:

From the simulation to the field – tray efficiencies

The tray efficiencies in Propylene Splitters have been a widely discussed issue. In actual operation they have ranged from 40 percent to 100%, so it is easy to see why this is a widely discussed issue. In general if the boiling points of the overhead product (light key component) and bottoms product (heavy key component) are close, less than 5 degrees C, the actual tray efficiency in the field will be high. If the boiling points of the overhead and bottoms product are far apart, the actual tray efficiency will be low. The ratio of the boiling points is classified as the relative volatility.

For example, a Propylene Splitter has close boiling points between the overhead and bottoms product, about 7 degrees C. This requires many ideal stages for separation in a process simulation, but each stage will have high efficiency in the field. For a normal cross-flowing tray 90% tray efficiency can be obtained. For chemical grade propylene, 95% purity, about 100 ideal trays might be required in a simulation, and 110 actual stages may be required in the field.

Tray efficiencies are generally classified as either overall efficiency (Fenske), point efficiency, or average tray efficiency (Murphree). The overall efficiency term is quite straightforward. It is the number of actual stages achieved versus the number of trays in the tower or section of the tower. Point efficiency and Murphree tray efficiency are similar. They represent the ratio of the actual compositional change and the theoretical compositional change at equilibrium. (2)

The compositional change is usually measured in the vapor phase but can be measured in the liquid phase. The difference between the point efficiency and Murphree tray efficiency calculation is the reference point. Point efficiency is measured at a specific point and the Murphree tray efficiency is measured across a complete tray. Therefore, the compositional gradients normally found on a tray will affect the Murphree tray efficiency but will not affect the point efficiency. When the liquid and vapor both have homogeneous compositions, point efficiency and Murphree tray efficiency will be equal.

In practical terms, trays with little or no liquid flow path length will essentially achieve point efficiency while trays with conventional flow path will achieve a higher Murphree tray efficiency due to the compositional gradient of the liquid flowing across the tray deck.

There are various aspects of equipment design that can affect efficiency. Any time a device can maximize the vapor/liquid contact while maximizing the compositional approach between the vapor and liquid, that device will maximize the efficiency of the tower. Conversely, any device characteristics that limit contact or compositional approach will lessen the efficiency of the tower.

Characteristics that may affect efficiency are discussed below.

Weir Height:

With trays operating in the froth regime, an increase in weir height will directionally increase the efficiency. Kister has noted that the removal of even a small outlet weir can noticeably decrease the effective tray efficiency. Weir height is especially important in liquid limited systems or systems where a slow chemical reaction is taking place. (2)

Flow Path Length:

Directionally, an increase in flow path length will increase efficiency. This was discussed earlier in the difference between point efficiency and Murphree tray efficiency. This holds true unless the length of the flow path creates anomalies in the tray operation such as liquid backmixing or vapor cross flow channeling. (2)

Liquid and Vapor Maldistribution:

As would be expected, vapor and liquid maldistribution will cause decreases in efficiency. Generally, maldistribution problems are generated by the distribution of feeds to the columns rather than by the contacting devices themselves. When reviewing internal designs it is very important to pay attention to feed pipe designs. Good liquid distribution across the tray is essential for high efficiency. Feed pipe designs that distribute liquid at high velocities should be avoided. Vapor distribution is also an important factor to consider. Most columns use

chimney trays vapor distribution devices.

Weeping and Entrainment:

Weeping and entrainment will also directionally cause decreases in efficiency. When considering the effects of weeping, it is important to differentiate between inlet side weeping and outlet side weeping. With inlet side weeping, the liquid will effectively miss two tray decks and the effects can be substantial. With outlet side weeping, only a small portion of the deck is missed and the effects

Design Case:

Below is a typical design case for a propylene splitter.

Typically a propylene splitter would be designed with 200 theoretical stages or between 290 to 310 actual trays. The column design being presented in this paper was designed with 200 theoretical stages. Simulation models showed that 200 theoretical stages produced 99.6-mole% propylene in the overhead product stream of this column. This is based on a column feed rate of 2700 lbmol/hr and an overhead heat duty of -282 mmBTU/HR. The reboiler duty of the column design being detailed is 180 mmBTU/HR.

This column has only one feed location. The composition range of the feed stream feeding the propylene splitter column is detailed in **TABLE 1**.

Typical design parameters for a propylene splitter column have been compiled in **TABLE 2**.

Design considerations that need to be addressed when considering a grass roots or revamped column

Operating Flexibility

The column should be designed with some operating flexibility. When reviewing the required efficiency, it is usually a good idea to review the sensitivity of the product purity to losses of efficiency in the tower. One way to do this is to construct a plot of required stages versus reflux ratio. (4) Knowing the sensitivity that reflux has on product purity will allow the designer to make a decision if the available reflux is sufficient to achieve the purity goal under different operating scenarios.

Minimum Reflux or Minimum Amount of Required Internals:

One design consideration is to determine the minimum reflux needed to achieve the required separation. In order to determine the amount of minimum reflux is required, one develops a reflux-stage plot and extrapolates from it. To develop this plot, simulation runs are performed at a various number of stages while keeping the material balance, product compositions, and the ratio of the feed stage to the number of stages constant. The reflux ratio is allowed to vary.

Then a plot of the number of stages versus reflux or reflux ratio is plotted. The curve is extrapolated asymptotically to an infinite number of stages to obtain the minimum reflux ratio. Once the minimum reflux has been determined then it must be decided if the design will be done at minimum reflux or with less installed internals. This is usually an economic choice. If the col-

umn is designed at minimum reflux the savings is lower required energy for the column operation. Usually the reboilers and condensers are smaller. The diameter of the column is also smaller. This choice may hinder future capacity revamps due to the size of the equipment. If the column is designed for minimum required internals required energy would be higher. The condenser and reboiler will be larger.

This option does give flexibility for future capacity upgrades. (1)

TABLE 1

Feed Stream Component	Composition Range (Mole%)
Propadiene	0.0 to 0.03
Propylene	92.0 to 96.0
Propane	4.0 to 7.0
Butanes	0.02 to 0.05
C5 non Aromatics	0.04
C6 non Aromatics	0.11
C7 non Aromatics	0.0
C8 non Aromatics	0.03
Benzene	0.0
Toluene	0.0

TABLE 2

Design Specifications	Overhead Of Column	Bottom Of Column
Tower Diameter(in)	200 to 300	200 to 300
Typical Number of Theo. Stages	133	70
Column Temperature($^{\circ}$ F)	20(Top)	44(Bottom)
Column Pressure (PSIA)	71(Top)	86(Bottom)
Propylene Mole% Column	99.6(Top)	14(Bottom)
Propane Mole% Column	0.04(Top)	81(Bottom)
PD Mole % Column	0.002(Top)	0.01(Bottom)

Optimization of Feed Stage:

Another design consideration is to design the column at the optimum feed stage location. Once all of the simulation runs are completed two main plots can be created. One plot will be a McCabe-Thiele diagram and the other will be a concentration versus feed stage diagram. The McCabe-Thiele diagram is plotted using the mole fraction data calculated for each stage by the simulation. The equilibrium data and the operating lines are also determined from the simulation results. Determining the optimal feed stage will help to maximize efficiency of the column. (2)

In the second type plot, the key component concentration in the product streams are plotted against the feed stage numbers. The minimum in the curve will represent the optimum feed stage. One can generally assume the ratio of optimum feed stage to total number of stages is independent of the number of stages. (2) In this type of plot it is important to note that the total number of stages is kept constant. Also, if the distillate rate is increased, it is normal to move the feed stage up the column as required. (1)

Conclusions:

In conclusion, it is important to note that when designing or revamping a propylene splitter great care must be taken during the design phase of the project. In order to get the maximum efficiency and capacity out of a propylene splitter one must consider the accuracy of the simulation and the thermodynamic model being used to model the column. Once the simulation has been completed great care must be taken when evaluating the sizing of new and existing equipment. Verification of the design which includes the amount of reflux required and feed location is essential to obtain maximum efficiency. All of these factors talked about in this paper are essential to obtain a good efficient design of a propylene splitter.

REFERENCES

1. Zygula, T. M., Dautenhahn, P. C. Ph.D., P.E. "Use of Process Simulation for Distillation Design" AIChE Spring National Conference, March 2000, Atlanta, Georgia.
2. Kister, H. Z. "Distillation Design", McGraw-Hill Book Company Inc., New York, 1992.
3. Zygula, T. M., Dautenhahn, P. C. Ph.D., P.E. "The Importance Of Thermodynamics On Process Simulation Modeling" AIChE Spring National Conference, March 2001, Houston, Texas.
4. Pilling, Mark, Column Efficiency – What to Expect and Why, Prepared for Presentation at 4th Topical Conference on Separations Science and Technology, November 1999 Session T1006 – Distillation Hardware and Application I.

ter.

Acknowledgements:

The authors acknowledges the contributions that friends and colleagues around the world have made through papers, presentations and discussions to understand distillation phenomena. The authors also want to thank the efforts made by friends to increase personal development - sometime with, and sometimes without success.



IACPE
INTERNATIONAL ASSOCIATION OF
CERTIFIED PRACTICING ENGINEERS

EXPAND YOUR HORIZONS

WWW.IACPE.COM