

# ENGINEERING PRACTICE

VOLUME 4 NUMBER 12

JANUARY 2018



# ENGINEERING PRACTICE

VOLUME 4  
NUMBER 12  
JANUARY 2018

## ACADEMIC BOARD

*Indonesia*

Yuli Amalia Husnil,  
ST.,MT.,PhD

Dr.Ir. Muaffaq A.Jani, M.Eng

Rini Oktavera S.T, M.MT

Ery Fatarina Purwaningtyas  
S.T, M.T

Rita Dwi Ratnani, ST., M.Eng  
Ir. Drs. H. Muradi Suwarg.ina  
MT

*Malaysia*

Ir. Dr. Dominic Foo

Dr. Sivakumar Kumaresan

## LEADERSHIP BOARD

**Karl Kolmetz**

**William B. Lotz**

**Lin L. Choo**

**Editor**

Karl Kolmetz

**Asian Assistant Editor**

Rita Targanski

**American Assistant Editor**

Shauna Tysor



## ABOUT

International Association of Certified Practicing Engineers provides a standard of professional competence and ethics. Identifies and recognizes those individuals that have meet the standard. And requires our members to participate in continuing education programs for personal and professional development.

In addition to insuring a professional level of competency and ethics the IACPE focuses on three major areas of development for our members: Personal, Professional, and Networking.

## HISTORY

The International Association of Certified Practicing Engineers concept was formulated by the many young professionals and students we meet during our careers working in the field, running training courses, and lecturing at universities.

During question and answer sessions we found the single most common question was: What else can I do to further my career?

We found, depending on the persons available time and finances, and very often dependent on the country in which the person was from, the options to further ones career were not equal.

Many times we found the options available to our students in developing countries were too costly and or provided too little of value in an expanding global business environment.

The reality is that most of our founders come from countries that require rigorous academic standards at four year universities in order to achieve an engineering degree. Then, after obtaining this degree, they complete even stricter government and state examinations to obtain their professional licenses in order to join professional organizations. They have been afforded the opportunity to continue their personal and professional development with many affordable schools, programs, and professional organizations. The IACPE did not see those same opportunities for everyone in every country.

So we set out to design and build an association dedicated to supporting those engineers in developing in emerging economies.

The IACPE took input from industry leaders, academic professors, and students from Indonesia, Malaysia, and the Philippines. The goal was to build an organization that would validate a candidates engineering fundamentals, prove their individuals skills, and enhance their networking ability. We wanted to do this in a way that was cost effective, time conscience, and utilized the latest technologies.

## MISSION

Based on engineering first principles and practical real world applications our curriculum has been vetted by academic and industry professionals. Through rigorous study and examination, candidates are able to prove their knowledge and experience. This body of certified professionals engineers will become a network of industry professionals leading continuous improvement and education with improved ethics.

## VISION

To become a globally recognized association for certification of professional engineers.

**IACPE**  
INTERNATIONAL ASSOCIATION OF  
CERTIFIED PRACTICING ENGINEERS

[WWW.IACPE.COM](http://WWW.IACPE.COM) | [INFO@IACPE.COM](mailto:INFO@IACPE.COM)

**KNOWLEDGE. CERTIFICATION. NETWORKING**

## LETTER FROM THE PRESIDENT

### KARL KOLMETZ

#### 2018: A Year to Grow



Dear Friends,

Thanks for your kindness and support for IACPE in 2017. IACPE is looking forward to 2018 to continue helping operations, maintenance and engineering personal increase their knowledge, become certified and build a great network. Our partnerships are growing and thriving with 11 partner universities, a partner training provider in India, and a partner association in Indonesia. Thank you for taking IACPE's mission and goals to heart.

IACPE is pleased and honored with the feedback received from the training modules. The Indonesian University Accreditation Board views them positively and we have received glowing remarks from university professionals. Many of the Level Two and Three modules are based on the *Kolmetz Handbook of Process Equipment Design*.

Our plan is to add additional universities in 2018 and to quickly reach our goal of 5,000 IACPE members worldwide. With a worldwide membership of 5,000, you will have access to a great network, which will have knowledge of your engineering education (Level One) and Practical Knowledge (Level Two and Three).

Level One's goal is to establish that you have gained a solid engineering education. Level Two and Three's goals are to then to build on that solid engineering education with practical knowledge that unifies your engineering fundamentals. IACPE encourages you to move into Level Two and Three when you complete Level One in order to further your knowledge.

Additionally, IACPE was asked by the Industrial Board Members to develop International Certification Programs. We have developed a project management, process safety, construction safety, commissioning specialist, and other relevant programs. The knowledge and certification from these programs would be a great asset to your career. Feedback from one of our Project Management Program enrollees was that the modules gave him everything he needed to interview well and obtain a position at as a project manager at a major firm.

We encourage you to continue to move forward in 2018 to build up your family, your friends and your career.

All the best in your Career and Life,  
Karl Kolmetz

**BECOME A CERTIFIED ENGINEER**



IACPE supports engineers developing across emerging economies focusing on graduates connecting with industrial experts who can help further careers, attaining abilities recognized across the industry, and aligning knowledge to industry competency standards.

IACPE offers certification in the following engineering fields:  
Mechanical, Metallurgy, Chemical, Electrical, Civil, Industrial, Environmental, Mining, Architectural, Bio, Information, Machine and Transportation.

**WWW.IACPE.COM**

# NEWS

## RECENT IACPE ACTIVITIES

IACPE Vice's President - William B.Lotz Presented "How To Compete in the 21st Century"



Sekolah Tinggi Teknologi Fatahillah - Cilegon, Banten  
November 20, 2017



Universitas Sultan Ageng Tirtayasa - Cilegon, Banten  
November 21, 2017



MOA sign - Engineering Faculty, Universitas Sultan Ageng Tirtayasa - Cilegon, Banten  
November 21, 2017



IACPE Networking Meeting with Companies  
November 21 November, 2017  
Greenotel Hotel-Cilegon, Banten



Institute Technology Indonesia - Serpong, Banten  
November 22, 2017



Universitas 17 Agustus 1945-Semarang, Central Java  
November 25, 2017



Universitas Kadiri - Kediri, East Java  
November 27, 2017



MOU & MOA sign - Engineering Faculty, Universitas Kadiri - Kediri, East Java  
November 27, 2017



MOU & MOA sign - Politeknik Kediri - Kediri, East Java  
November 28, 2017



Universitas 17 Agustus 1945 - Surabaya, East Java  
November 29, 2017



MOU & MOA sign - All Dept. of Engineering Faculty & Magister Program, 17 Agustus 1945 - Surabaya, East Java  
November 29, 2017



Universitas Wahid Hasyim - Semarang, Central Java  
November 30, 2017



MOA Sign Engineering Faculty, Universitas Wahid Hasyim - Semarang, Central Java  
November 30, 2017

## IACPE - PARTNERS



**Universiti  
Malaysia  
PAHANG**  
Engineering • Technology • Creativity



IKATAN SARJANA  
TEKNIK INDUSTRI  
DAN MANAJEMEN INDUSTRI  
INDONESIA

### Become International Certified Engineer

**IACPE**  
INTERNATIONAL ASSOCIATION OF  
CERTIFIED PRACTICING ENGINEERS

**KNOWLEDGE**

**CERTIFICATION**

**NETWORKING**

CERTIFIED CRUDE OIL ANALYST  
CERTIFIED CONSTRUCTION SAFETY SPECIALIST  
CERTIFIED PRACTICING COMMISSIONING SPECIALIST  
CERTIFIED PRACTICING PROJECT MANAGER  
CERTIFIED PRACTICING RISK SPECIALIST  
CERTIFIED PRACTICING SAFETY PROFESSIONAL  
CERTIFIED PROCESS TECHNICIAN  
EXECUTIVE CPE



**AUTHORIZED AGENT**

**NiEP**

www.niep.in - info@niep.in

INDIA +91 9747606616  
KUWAIT +965 65916313  
info@niep.in

## OVER 200+ SUCCESSFUL OFFSHORE PROJECTS



### Flow Induced Vibration

#### Limits

Frequency Range	Displacement	Velocity	Acceleration
10 - 100 Hz	0.10	1.00	0.10
100 - 1000 Hz	0.01	10.00	1.00
1000 - 10000 Hz	0.001	100.00	10.00
10000 - 100000 Hz	0.0001	1000.00	100.00
100000 - 1000000 Hz	0.00001	10000.00	1000.00
1000000 - 10000000 Hz	0.000001	100000.00	10000.00
10000000 - 100000000 Hz	0.0000001	1000000.00	100000.00
100000000 - 1000000000 Hz	0.00000001	10000000.00	1000000.00
1000000000 - 10000000000 Hz	0.000000001	100000000.00	10000000.00
10000000000 - 100000000000 Hz	0.0000000001	1000000000.00	100000000.00
100000000000 - 1000000000000 Hz	0.00000000001	10000000000.00	1000000000.00
1000000000000 - 10000000000000 Hz	0.000000000001	100000000000.00	10000000000.00
10000000000000 - 100000000000000 Hz	0.0000000000001	1000000000000.00	100000000000.00
100000000000000 - 1000000000000000 Hz	0.00000000000001	10000000000000.00	1000000000000.00
1000000000000000 - 10000000000000000 Hz	0.000000000000001	100000000000000.00	10000000000000.00
10000000000000000 - 100000000000000000 Hz	0.0000000000000001	1000000000000000.00	100000000000000.00
100000000000000000 - 1000000000000000000 Hz	0.00000000000000001	10000000000000000.00	1000000000000000.00

### Compressor Degradation

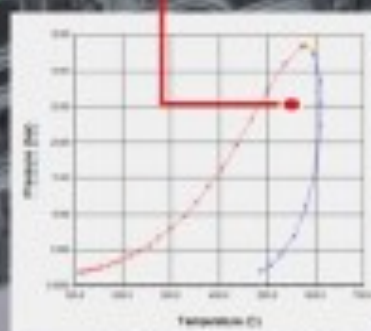
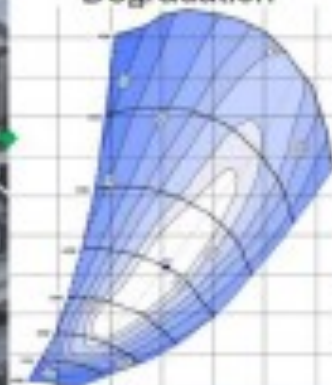

## APPS FOR PROCESS SIMULATION

INCREASE CAPACITY | IMPROVE MARGINS | REDUCE COSTS | BECOME MORE ENERGY EFFICIENT | ACHIEVE OPERATIONAL GOALS

Providing independent and trusted third-party specialist consultancy and software services to the upstream oil & gas industry.



+47 67 56 99 90

info@bpt.no

Lekketangen 20, 1337 Sandvika, Oslo, Norway

www.bpt.no

# How to Compete in the 21st Century

Part I – Predicting the Future

Karl Kolmetz

IACPE

## Introduction

We travel all around the world speaking at many colleges and companies. One of the questions we were asked by an Indonesian Student in October 2017 was; How can we compete with the 1<sup>st</sup> world countries? Put another way might be; How can we compete with other people who may have better opportunities? And, how can we be the best in the world?

This can be looked at in two or more levels. One level is what might be the future of engineering and what technical skills do I need to master to be relevant in the future? A second level is what personal skills do I need to master to be relevant in the future?

Both questions will have a large impact on your success in the future. As a young engineer I believed that my technical ability and hard work were enough to be successful. And this is true, but if you add good personal skills to your technical ability and hard work, you can accomplish two or three times more than what your technical ability and hard work will alone.

Predicting the future is at best guessing. But there are definite trends where engineering is heading and the skills that will be needed in the future. My Grandfather rode a horse to propose to my Grandmother in 1919, just 100 years ago. As a child in 1957 my Grandmother's house did not have running water or indoor bath rooms. I remember sleeping in front of a fireplace under blankets in the winter. Just think of how far engineering has advanced in 100 years. I expect that engineering will even move faster in the future and you will need to continually improve your skills the rest of your life to be able to compete in the future.

Engineering, through its role in the creation and implementation of technology, has been a key force in the improvement of our economic well-being, health, and quality of life. Three hundred years ago the average life span was 37 years, the primary effort of most humans

was focused on providing food, and the threat of sudden demise due to disease was a lurking reality (4).

Today, human life expectancy is approaching 80 years in many parts of the world as fundamental advances in medicine and technology have greatly suppressed the occurrence of and mortality rates for previously fatal diseases and the efforts of humankind are focused largely on enhanced quality of life (5).

Only 150 years ago travel from the USA to Asia entailed a hazardous journey that took many weeks to accomplish. Weeks were needed to transmit a letter. Today, in the developed world, we take it for granted that transportation is affordable and reliable, good health care is accessible, information and entertainment are provided on call, and safe water and healthy food are readily available.

To be sure, there have also been negative results of technology. Pollution, depletion of scarce resources, and catastrophic failures of poorly designed engineering systems are examples. Overall, however, engineers and their inventions and innovations have helped shape the changes that have made our lives more productive and fruitful.

As much as engineering has changed in the last 100 years, people are relatively the same. Developing great personal skills and dealing with people and their challenges may remain the same in the next 100 years. To be successful today and the future you will need to learn how to manage yourself and others. This we will discuss in a future article.

## Engineering Education

Engineering education and its nature have been debated for many years. Change typically comes in waves, often following from forces outside the education establishment. Fallout from the surprising success of the launch of the Russian satellite Sputnik led to reinforcement of the "engineering science" paradigm.

The impacts of the recession of the early 1980s and subsequent reconstitution of the competitiveness of American industry and the dramatic failure of the space shuttle Challenger in the mid-1980s aided the movement toward more attention to quality principles and communication and teamwork skills. Presently, it is important that engineering education be reconsidered in a futures-based approach driven from within engineering.

We believe that engineering educators and practicing engineers together undertake a proactive effort to prepare engineering education to address the technology and societal challenges and opportunities of the future. With appropriate thought and consideration, and using strategic planning tools, we should reconstitute engineering curricula and related educational programs to prepare today's engineers for the careers of the future, with due recognition of the rapid pace of change in the world and its intrinsic lack of predictability. (1)

### Where Engineering is Most Likely Heading

There are several likely areas where engineering is most likely heading, and these are areas where you need to develop your engineering skills. These include; Biotechnology, Nanotechnology, Materials Science, Photonics / Optics, Information and Communications Technology, Robotics, Artificial Intelligence, and



**PT Dinamika Teknik Persada provide Engineering Design to the upstream and downstream sectors of oil & gas industry:**

- Processing plants
- Pressure vessels
- Heat exchangers
- Piping systems
- Onshore pipelines
- Offshore pipelines

Improved Process / Automation Control for many of these technologies.

There are key attributes that will support the success and relevance of the engineering profession in the future. The discussion may be framed by certain guiding principles that will shape engineering activities in the future. A partial list might be;

- The pace of technological innovation will continue to be rapid (most likely accelerating).
- The world in which technology will be deployed will be intensely globally interconnected.
- The population of individuals who are involved with or affected by technology (e.g., designers, manufacturers, distributors, users) will be increasingly diverse and multidisciplinary.
- Social, cultural, political, and economic forces will continue to shape and affect the success of technological innovation.
- The presence of technology in our everyday lives will be seamless, transparent, and more significant than ever.

## PT. Dinamika Teknik Persada

is an Engineering Consultants focused on providing engineering and technical services to the oil and gas industry.

We develop innovative and cost effective solutions and helping our clients to achieve high performance from their assets by providing expertise, novel methods and appropriate tools

- FEED to Detailed engineering Design
- Independent Design Verification
- Risk Assessments
- Asset Integrity Management
- Risk Based Inspection



Address : Ruko Golden Boulevard Blok K No. 1-2  
 Jl. Pahlawan Seribu, BSD City, Serpong  
 Tangerang 15322 – Indonesia  
 Phone / Fax : +62 21 53150601  
 Email : [info@ntp-eng.com](mailto:info@ntp-eng.com)

## Biotechnology

Exciting breakthroughs in our understanding of human physiology have been among the most captivating topics of discussion over the past several years. It is the potential to attack diseases and disorders at the cell and DNA levels that leads some to believe that diseases, as currently known, may be eradicated and that compensations for many of the limitations of the human body (e.g., those related to aging or hormonal changes) will be available.

Advances in biotechnology have already significantly improved the quality of our lives, but even more dramatic breakthroughs are likely. Research in tissue engineering and regenerative medicine may lead to new technology that will allow our bodies to replace injured or diseased parts without invasive surgery, but rather by using the natural growth processes inherent in cells. Already used extensively to help burn victims grow replacement skin, it is possible that related developments will allow spinal cord injury victims to restore full mobility and feeling by reconnecting tissues and nerves. (1)

## Nanotechnology

“Nanoengineering” to create and manufacture structures and materials on a molecular level will continue as a focus for the next few generations of engineers. Nanoscience and nanoengineering draw on multiple fields, as reflected in applications in bioengineering (e.g., genetic and molecular engineering), materials science (composites and engineered materials), and electronics (quantum-scale optical and electrical structures).

Nanostructures have been proposed as environmental cleaning agents, chemical detection agents, for the creation of biological (or artificial) organs, for the development of nanoelectronic mechanical systems (NEMS), and for the development of ultrafast, ultradense electrical and optical circuits. In a marriage of engineering and biology to create synthetic biology, efforts are proceeding to create a suite of fundamental tools and techniques to fabricate biological devices, analogous to those used to create microelectronic devices (2).

## Materials Science and Photonics / Optics

Even in traditional areas of engineering, like bridge and automotive design, civil and mechanical engineers will increasingly need to understand new materials that can be used in composites, atomic-

scale machines, and molecular-based nanostructures. Smart materials and structures, which have the capability of sensing and responding, for example, to displacements caused by earthquakes and explosions, will be used increasingly.

If the present petroleum economy is replaced by a hydrogen economy, fuel cells will replace the internal combustion engine and batteries as power sources, and a general understanding of fuel-cell-powered engines, fuel-cell chemistry, and the materials of fuel cells will be needed. Moreover, as smart materials are used in advanced products, material properties based on mechanical, optical, and electromagnetic interactions become core knowledge topics that support effective engineering practice.

As the physical sizes of optical sources decrease while their power and reliability continue to increase, photonics-based technologies will become more significant in engineered products and systems. Fiber optics communications, precision manufacturing applications (e.g., precision cutting, visioning, sensing), and applications employing free space line-of-sight optical links, laser guidance, and optical sensing and monitoring will continue to advance. (3)

## Information and Communications Technology

To appreciate the potential of information technology, one has only to consider the remarkable changes that have taken place in society in the past few decades. Today young adults cannot imagine life without computers, video conferencing, mobile phones, copiers, and the Internet, and most of us who are old enough to have lived without them appreciate them even more. Everything will, in some sense, be “smart”; that is, every product, every service, and every bit of infrastructure will be attuned to the needs of the humans it serves and will adapt its behavior to those needs.

For engineering the imperative to accommodate connectivity establishes an integral role for core competencies related to electronics, electromagnetics, photonics, and the underlying discrete as well as continuous mathematics. Core competencies in materials and the cultivation of skills related to the use of information technology for communications purposes are also indicated. Engineers and engineering will seek to optimize the benefits derived from a unified appreciation of the physical, psychological, and emotional interactions between information technology and humans.



# Partners to the Top

Summit Technology Management is a technical consultancy group, providing specialized services and training to improve process plant operational efficiency, profitability and safety. We provide engineering solutions by offering training, technical services, best practices, and equipment to meet the specific needs of our partner clients.

- Basic Design Packages
- Detailed Design Packages
- Commissioning of Process Units
- Process Engineering Studies
- Bench Marking of Process Units
- Regional Training Conferences & In-House Training
- Singapore & Malaysia Company Registration & Set Up
- Specialty Equipment: Distillation Equipment, Filter Skid Packages, Compressor Knockout/Scrubber Skid Packages, Mercury Removal Skid Packages
- Process Safety Management Consulting
- HAZOP Facilitation



As engineers seek to create products to aid physical and other activities, the strong research base in physiology, ergonomics, and human interactions with computers will expand to include cognition, the processing of information, and physiological responses to electrical, mechanical, and optical stimulation.

Given the expected role of computers in the future, it is essential that engineers of all disciplines have a deep working knowledge of the fundamentals of digital systems as well as fluency in using contemporary computer systems and tools. Many, if not all, engineering systems in the future will be digital systems. Advances in computing and simulation, coupled with technologies that mimic rudimentary attributes in analysis, may radically redefine common practices in engineering.

### Robotics

What does the future hold for robotics? It's hard to say, given the rapid pace of change in the field as well as in associated areas such as machine learning and artificial intelligence. But one thing seems certain: Robots will play an increasingly important role in business and life in general. (6)

Technological development in artificial intelligence, computer vision, navigation, MEMS (Micro Electro Mechanical Systems) sensor, and semiconductor technologies continue to drive innovation in the capability, performance, autonomy, ease of use, and cost-effectiveness of industrial and service robots. Robotics will continue to accelerate innovation, thus disrupting and changing the paradigm of business operations in many industries.

Companies in the future will need to embrace and assess how robotics can sharpen their company's competitive edge by improving quality, increasing operational productivity and agility, and enhancing experiences of all stakeholders.

The boundaries between smart materials, artificial intelligence, embodiment, biology, and robotics are blurring. This is how robotics will really affect humans over the next twenty to forty years. From robots that can monitor and repair the natural environment to nano robots to track and kill cancer, and from robots that will lead the way to planetary colonization to robot companions to keep us from loneliness in old age. There is no part of our society or life that will not be affected by future robotics.

### Artificial Intelligence

The world's top tech companies are in a race to build the best AI and capture that massive market, which means the technology will get better fast—and come at us as fast. IBM is investing \$1 billion in its Watson; Amazon is banking on Alexa; Apple has Siri. Google, Facebook and Microsoft are devoting their research labs to AI and robotics. Salesforce.com announced its adding AI, called Einstein, to its business software. Its value, will be in helping people do the things that people are good at and turning more things over to machines. (7)

Versions of AI have been around for decades. Google's search engine is so accurate because it is built on AI and learns from billions of searches. AI is how Facebook directs items you most likely want to see to your news feed. But for AI to be powerful enough to drive a truck or diagnose patients, it needs a few things that are just now exploding onto the scene. One is enormous amounts of data. Now that we do so many things online, every action gets recorded and stored, adding valuable data that can fuel AI.

Successful people in the AI age will focus on work that takes advantage of unique human strengths, like social interaction, creative thinking, decision-making with complex inputs, empathy and questioning. AI cannot think about data it doesn't have.

It predicts what you want to see on Facebook based on what you've already liked. It can't predict that you might like something that's entirely different. Only humans can think that way. Possibly the most valuable people in an age of push-button answers will be the people who ask the most interesting questions.

### Improved Process / Automation Control

Improved Process / Automatic control is the cornerstone of the new automation revolution and can be considered fundamental in such broad areas as household appliances, consumer electronics, production and manufacturing systems, chemical, mechanical and electrical processes, civil, aerospace and transportation systems and it even has cross interaction links with economic, social, biological and medical systems.

Basic control systems principles influence all these areas of application. Therefore, industrial requirements for well-prepared control systems engineers are evolving, due to marketplace pressures and progress in technology. (8)

- Control engineering is an inherently interdisciplinary field.
- Mathematics has played and will increasingly continue to play a fundamental role in the development of control engineering.
- The interrelation between mathematics and control engineering has been closely intertwined right from the start.
- Advances in the control field are made through a mix of mathematics, modeling, computation, and experimentation.

Control is also a mission-critical function in engineering systems: the systems will fail if the control system does not work. Contributions to the field of control come from many disciplines, including pure and applied mathematics; aerospace, chemical, mechanical, and electrical engineering; operations research and economics; and the physical and biological sciences. The interaction with these different fields is an important part of the history and strength of the field. (9)

The modern control engineer is put in the role of being a systems engineer, responsible for linking the many elements of a complex product or system. This requires not only a solid grounding in the framework and tools of control, but also the ability to understand the technical details of a wide variety of disciplines, including physics, chemistry, electronics, computer science, and operations research. Leadership and communication skills are critical for success in these environments.

In addition, control is increasingly being applied outside its traditional domains in aeronautics, chemical engineering, electrical engineering, and mechanical engineering. Biologists are using ideas from control to model and analyze cells and animals; computer scientists are applying control to the design of routers and embedded software; physicists are using control to measure and modify the behavior of quantum systems; and economists are exploring the applications of feedback to markets and commerce.

## Conclusions

Since the question in October of 2017, I have thought about the future of engineering and how we as educators might help our students prepare for the future with the technical and personal skills that they will require.

The fundamental knowledge requirements will stay the same, and this is what we are focusing on in IACPE Certified Practicing Engineer Level One. In each of the above-mentioned areas, fundamental knowledge is required and in fact a broad base of fundamental knowledge is required.

We get comments that the Level One Modules may be too technical. After writing this paper and reviewing the future needs of engineering, we may need to increase the technical levels of our modules. If you do not have solid technical fundamental training, you will limit your future opportunities. We may need to add an additional CPE Level One module on the future trends of engineering and why the fundamentals of the difference fields are important to master.

A second consideration is our Continuing Education Requirements. After two years we are requiring Continuing Education to keep your Certification. At first, we had considered two hours study per year, and a yearly fee of USD 30.00 for the two courses. After this review I no longer believe that two-hour study per year is sufficient to stay current with the fast pace growth of engineering science. We will increase the requirement to four-hours per year, but maintain the same yearly fee.

## References

1. The Engineer of 2020: Visions of Engineering in the New Century, National Academy of Sciences
2. Ball, 2001; National Research Council, 2003
3. Board on Chemical Sciences and Technology, 2003; Suhir, 2000
4. Kagan et al., 2001
5. Central Intelligence Agency, 2001
6. Bob Violino, The future of robotics: 10 predictions for 2017 and beyond
7. Kevin Maney. HOW ARTIFICIAL INTELLIGENCE AND ROBOTS WILL RADICALLY TRANSFORM THE ECONOMY
8. S. Dormido Bencomo, CONTROL LEARNING: PRESENT AND FUTURE
9. Future Directions in Control in an Information Rich World



**ENGINEERING DESIGN  
SOFTWARE**

**SPECIALIZED TECHNICAL  
ARTICLES AND BOOKS**

**DETAILED ENGINEERING DESIGN  
GUIDELINES**

**PROJECT ENGINEERING  
STANDARDS AND  
SPECIFICATIONS**

**TYPICAL PROCESS UNIT  
OPERATING MANUALS**

**TRAINING VIDEOS**

**KLM Technology Group** is a technical consultancy group, providing specialized services and training to improve process plant operational efficiency, profitability and safety. We provide engineering solutions by offering training, technical services, best

practices, and engineering designs to meet the specific needs of our partner clients. Since 1997, KLM Technology Group has been providing engineering, operations, and maintenance support for the hydrocarbon processing industry.

**[WWW.KLMTECHGROUP.COM](http://WWW.KLMTECHGROUP.COM)**

**Engineering Solutions, Standards, and  
Software**

**KLM**

**Technology  
Group**

# Understanding Centrifugal Compressor

## Surge and Control

Jayanthi Vijay Sarathy, M.E, CEng, MIChemE,

Ask a chemical or mechanical engineer, what does a compressor surge do, and he would shudder merely thinking of the consequences. The centrifugal compressor is the heart of any oil & gas facility and since the last 100 years has been subjected to scrutiny as to what is the perfect control mechanism. Surge in a centrifugal compressor can be simply defined as a situation where a flow reversal from the discharge side back into the compressor casing occurs causing mechanical damage.

The reasons are multitude ranging from driver failure, power failure, upset process conditions, start up, shutdown, failure of anti-surge mechanisms, check valve failure to operator error to name a few. The consequences of a surge are more mechanical in nature whereby ball bearings, seals, thrust bearing, collar shafts, impellers wear out and sometimes depending on the how powerful are the surge forces, cause fractures to the machinery parts due to excessive vibrations.



**Figure 1. Bearings dislodged from containment**

Here is an image that shows the bearings being dislodged from its containment. The effects of surge are also contagious and due to excessive shaft vibrations, the gearbox connected between the compressor and the driver is also not spared at the bearings and gear teeth. The power of a

surge is also proportional to the capacity (flow, power, pressure ratio) and even in the case of small turbo compressors, the gear teeth wear out when the impeller rotates in the opposite direction during a surge. The bottom line is - *Always Avoid a Surge in Rotating Equipment.*

### Typical Single Stage Compression System

A typical single stage compressor system shown in Figure 1, consists of,

1. A centrifugal compressor driven by a gas turbine, steam turbine or electric motor.
2. A suction scrubber to disengage any carryover liquids that can potentially wear out impellers that run at high velocities of the order of 200 m/s to 500 m/s.
3. A discharge cooler to cool the compressed vapours to the required export temperature.
4. Check valves at compressor discharge to prevent any backflow of vapours into the compressor in the event of a surge.
5. An anti-surge valve (ASV) that recycles cold gas from the discharge cooler to the suction to keep the operating point away from the surge line.
6. A hot gas recycle, if the ASV is inadequate.

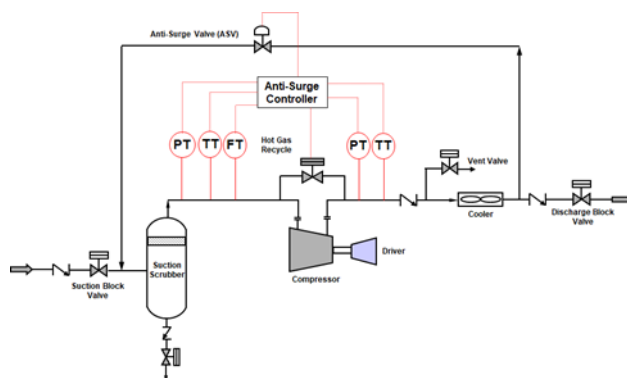

**Figure 2. Typical Centrifugal Compression System**

# Your Partner for Fabrications

**BROADWIND ENERGY. SOLUTIONS FOR THE ENERGY NEEDS OF THE FUTURE.**

Broadwind Energy is a precision manufacturer of structures, equipment and components for clean tech and other specialized applications. Our technical expertise, manufacturing footprint and collaborative processes produce high quality fabrications and welded assemblies for strategic partners within the North American market.



300 Wall Street

Abilene, TX 79603

General: 325.437.5950

Sales: 325.201.7067

[info@bwen.com](mailto:info@bwen.com)

[www.bwen.com](http://www.bwen.com)



**INDUSTRIAL FABRICATIONS | TOWER MANUFACTURING | GEARING**

## Compressor Surge Protection Agents

### Anti-surge Valve (ASV)

The chief protecting agent in a centrifugal compressor is the anti-surge system that consists of a control valve with the associated piping. The ASV recycles cold gas from the discharge side cooler back to the compressor via the suction scrubber to keep the operating point away from the surge line.

### Hot Gas Recycle Valve (HGV)

Although the anti-surge valve is the chief protector, in brownfield projects, often the ASV becomes inadequate to deal with a compressor surge due to addition of new compressors in parallel or series (e.g., booster compressors), change of plant piping or change of vapour composition. In such situations, a necessity arises to recycle more flow for which an additional ASV with quick opening characteristics is installed in parallel to the first ASV. When such solutions still fail to stop a surge event from occurring, a hot gas recycle (HGV) is used as a last resort. The HGV is always to be used in tandem with the ASV and only during an emergency shutdown (ESD). Excessive hot gas recycle also shortens the efficacy of the lube oil that is used for lubrication purposes. Figure 3 shows an example of ASV inadequacy leading to recycling insufficient vapour to the suction during a sudden trip caused by power failure.

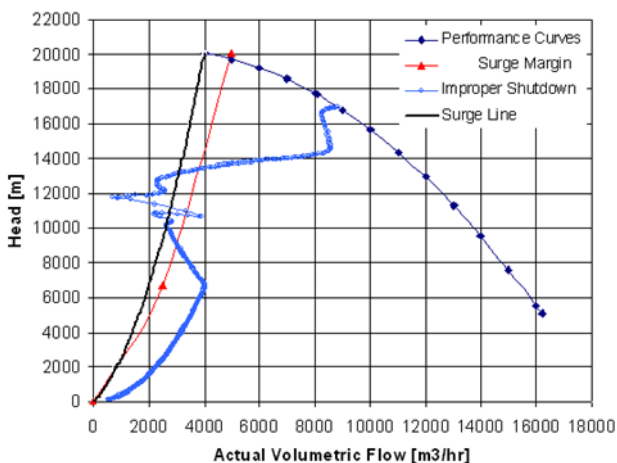

**Figure 3. Surge during an Emergency Shutdown**

Figure 4 shows a hot gas recycle installation that compensates for the ASV's deficiency, thereby keeping the operating point away from the surge line during an ESD.

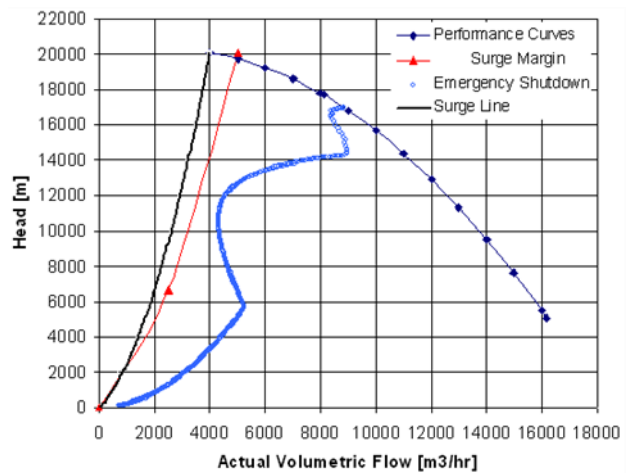

**Figure 4. Surge Avoided with Hot Gas Recycle**

In recent decades, with tools such as dynamic simulation, the quantity of hot gas to be recycled can be determined without recycling immoderate amounts of hot gas that can overheat the gas compressor with bearings and seals failing.

### Requirements of an Anti-surge Valve (ASV) and Hot Gas Recycle Valve

A hot gas recycle/bypass system consists of piping with an On-Off Valve that is motor or pneumatic operated and should have a full opening time of < 1 sec (for valves between 4 inch to 16 inch). For larger On-Off Valves (above 16 inch), the time is taken to be < 2 sec. In the case of an electric motor driven compressor, the power dependent lost during a power failure the motor

operated HGV becomes futile. The hot gas valve and ASV should be fail open type and is sized for twice the flow required to keep the operating point away from surge. During operation, fluids velocities must be kept less than 0.3 Mach which otherwise causes damage to the valve and piping due to erosion. A noise limit of 110 dB is also placed and operating at around 85 dB is acceptable. For good pressure throttling, the ASV is

equipped with linear opening characteristics or a combination of equal percentage characteristics up to ~40% opening with the remaining travel substituted with linear characteristics. The hot gas piping should be laid as short as possible between the discharge and suction to have a fast response.

During an ESD scenario (e.g., power loss), taking a conservative approach for design purposes, the control output signal from the compressor driver after a trip, takes ~300 msec to reach the Distributed Control System (DCS) and another ~300 msec from the DCS to reach the HGV to open. However with advances in technology, these timings can be considered at ~100 msec. *In simple terms, a lower response time increases the chances of responding faster to a compressor surge*

### Deviations from Design Criteria

As a thumb rule, the hot gas system is sized for 50% (max) during FEED stage. However this needs to be checked with a dynamic simulation study since over-sizing the hot gas system recycles excessive flow that causes the bearings and seals to overheat.

As per API 617 (7<sup>th</sup> Edition, 2002), Clause 2.7.1.3, it states, '*As a design criteria, bearing metal temperatures shall not exceed 100°C (212°F) at specified operating conditions with a maximum inlet oil temperature of 50°C (120°F). Vendors shall provide bearing temperature alarm and shutdown limits on the datasheets.*' However clause No. 2.7.1.3.1 of the said document also says, '*In the event that the above design criteria cannot be met, purchaser and vendor shall mutually agree on acceptable bearing metal temperatures.*'

In reality, the Author has seen cases, where this deviation was taken up to ~135°C depending on the manufacturer and believes that this is due to a variation of operating conditions between string test conditions and actual conditions. Nevertheless, compressor operating temperatures must never exceed the stipulated or mutu

ally agreed values in order to protect the compressor's internals.

### Compressor Control Systems

In today's world no piece of machinery can be said to be protected by modern methods without implementing a control system. A surge can occur in a matter of seconds or sometimes even milliseconds giving almost no time for operators to intervene. Hence a control system becomes a part and parcel of the compressor package.

Although the good old Proportional-Integral-Derivative (PID) control was enough to avoid a surge by minimizing the compressor recycle flow, it did not aid much in reducing / optimizing the power requirements. With a steady rise in the oil consumption since the 1970s, the necessity of energy efficiency, safety and environmental friendliness became a priority and demanded better control systems.

To respond quickly to any process upsets, high computational speeds in controllers also became a necessity. This led to the rise of specialized control equipment known as 'Black Boxes' that was the alternate to panel mounted instruments. Black boxes though addressed response times, suffered from frequent hardware and software revisions.

Black box technology was proprietary with its own coding languages and often experienced compatibility issues when interfacing between different manufacturer's models. This also meant having to sometimes shutdown the machinery causing monetary implications and increased downtime if not made part of plant maintenance.

### Advent of Programmable Logic Controller

With the limitations of black box technology being recognized, industry honchos realized the necessity of standardizing and generalizing control systems and their respective programming languages. These standardization efforts led to

documenting the IEC 61131 (International Electrotechnical Commission Standard for Programmable Controllers) in 1993 and subsequently revised in 2003.

Programmable Logic Controllers (PLCs) provided not only computational power but also were easily integrate-able to the compressor controls. PLC's offered the advantage of scalability where new I/O's could be added during any form of plant modification/expansion depending on the type of PLC used (e.g., modular or stacked). PLCs also offer diagnostics capabilities, for example, to trace through the logs of controller output during a fault analysis.

In earlier systems, as shown in Figure 5, a primary PLC is supplemented with an auxiliary PLC that controlled systems like lube oil, seal oil / dry gas seals, start up sequencing, interlocks, etc. This also required interfacing them properly to allow operators to diagnose and do a root cause analysis in the event of, for example, a compressor trip.

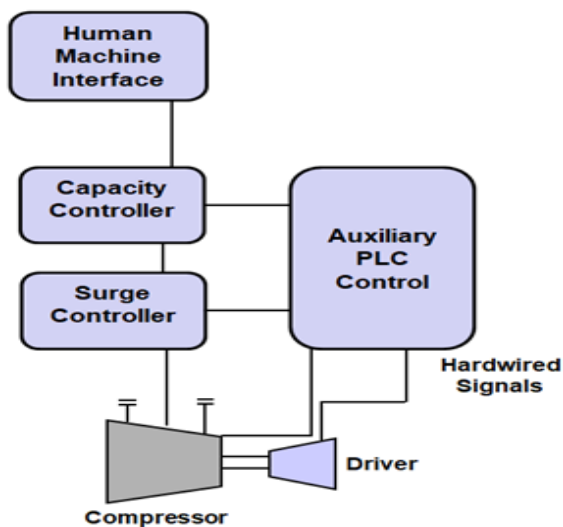

**Figure 5. Compressor System with Interfaces**

However with integrated systems as shown in Figure 6, that used a dedicated control PLC with a backup PLC and the necessary hard wiring, the cost of implementation also comes down, offering better efficiency, diagnostics, generic parts and scalability.

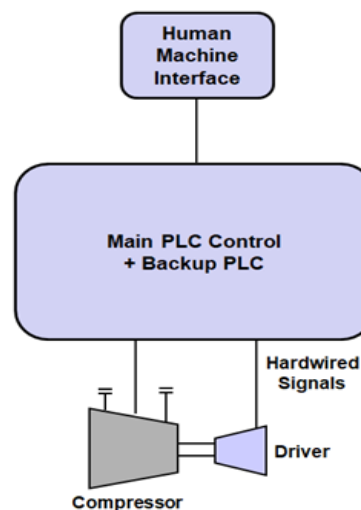

**Figure 6. Compressor System with Integrated Interfaces**

### References

'Axial and Centrifugal Compressors and Expander-compressors for Petroleum, Chemical and Gas Industry Services', API Standard 617, 7<sup>th</sup> Edition, July 2002

'Compressor Control: Moving Beyond "Black Boxes" to Integrated, Automated Platforms in Oil and Gas Production', Rick McLin, Turbomachinery Controls Business Manager, Rockwell Automation



### About the Author

Vijay Sarathy holds a Master's Degree in Chemical Engineering from Birla Institute of Technology & Science (BITS), Pilani, India and is a Chartered Engineer from the Institution of Chemical Engineers, UK. His expertise over 10 years of professional experience covers Front End Engineering, Process Dynamic Simulation and Subsea/Onshore pipeline flow assurance in the Oil and Gas industry. Vijay has worked as an Upstream Process Engineer with major conglomerates of General Electric, ENI Saipem and Shell.

# PROCESS

ENGINEERING ASSOCIATES, LLC  
"Excellence in Applied Chemical Engineering"

## Corporate Office

700 South Illinois Ave.  
Suite A-202  
Oak Ridge, TN 37830

Phone: +1 (865) 220-8722

## Process Engineering Associates, LLC Process Engineering International, LLC

We provide engineering services exclusively via highly qualified chemical engineers and we specialize only in process engineering. Our industrial process design and plant operations experience are extensive. Our companies provide only Chemical Engineering process design and process safety services and currently employ over 50 highly qualified, full-time chemical engineers.

Our services are provided to most industrial process markets including chemical / petro-chemicals, petroleum refining, alternative fuels, power generation, metals/mineral processing industries, foods, pharmaceuticals, and more.



**PROCESS'** personnel are experienced, highly motivated Chemical Engineers with track records of significant achievement in the process engineering field.

**PROCESS** has experience in providing exceptional process design services for the development of conceptual and detail process design, process modeling and simulation, and operations support. Typical services include process option screening studies/evaluations, preliminary process designs (FEL & FEED), comprehensive Schedule A process design packages, detail engineering process support, process construction oversight, startup assistance, and more.

## Overview of Services

We specialize in process chemical engineering, process design, and process safety.

- ◆ Process Design
- ◆ Process Modeling/Simulation (CHEMCAD / AspenPlus / HYSYS / etc.)
- ◆ Operations Support
- ◆ Process Safety Management
- ◆ Safety Instrumented Systems / ISA Compliance
- ◆ Additional Capabilities



Please visit our websites at  
<http://www.ProcessEngr.com>  
and <http://www.ProcessEngr-Intl.com>.

# Lower Environmental Impact to Oil Refining Process Sour Water Stripping Units

## Introduction

Just like any other chemical processes industry, the oil refining presents a great environmental impact. Through decades engineers, scientists and researchers have dedicated efforts to minimize the environmental footprint from petroleum refining.

Some of the major impacts produced by crude oil processing are the water and atmospheric emissions.

The petroleum derivatives production needs a large amount of water for cooling fluid, steam generation or to direct use in the process like in the crude oil desalting step. Water has become an increasingly scarce resource and any effort dedicated to reducing the volume applied in the process is welcome.

## Sour Water Stripping Process

One of the most important environmental process units in a petroleum refinery is the so-called sour water stripping unit. Sour water is the water that had contact with the petroleum or his derivatives during some step in the process, this contact can be like rectification steam in distillations columns or in contact with hydrocarbon phases. Contaminants like  $\text{NH}_3$  and  $\text{H}_2\text{S}$  tends to concentrate in the aqueous phase, so the sour water commonly has high concentration of these compounds.

The Sour Water Stripping Unit apply the concept of fluid rectification with steam and the partial pressure reduction to move the phase equilibrium to the vapor phase, releasing the contaminants from the liquid, like presented in Figure 1.

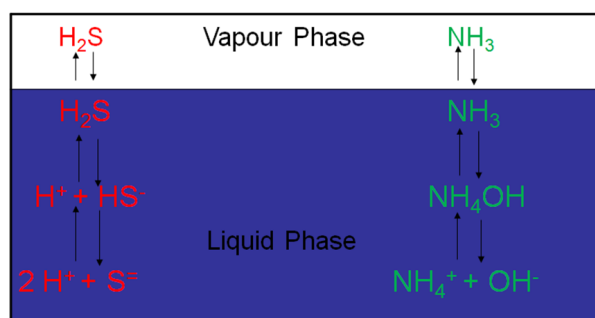

Figure 1 – Phase Equilibrium in Sour Water Stripping Process

Like any other process technology, the sour water stripping unit was developed and improved along the time, mainly to reduce atmospheric emissions and to raise the water reuse in the refineries

## Design Concepts

The initial design concept for sour water stripping units had one rectifying tower, in this tower both contaminants ( $\text{NH}_3$  and  $\text{H}_2\text{S}$ ) were removed and form the stream called sour gas like described in Figure 2.

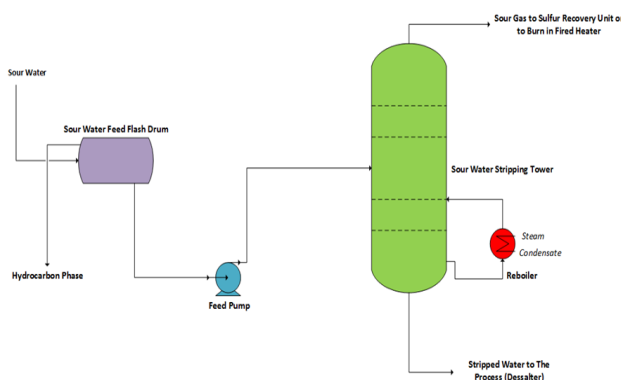

Figure 2 – Typical Arrangement for Sour Water Stripping Unit with Single Tower

In these cases, the tower operates with relatively low pressure (about 1,0 kgf/cm<sup>2</sup>).

Initially, the designs predict to send the sour gas to burn in fired heaters, like in distillation units. Nowadays, with the environmental restrictions and the necessity to reduce  $\text{SO}_x$  and  $\text{NO}_x$  emissions the project concept were changed and the sour gases



# PT. WARU TEKNIKATAMA

HEAT TRANSFER TECHNOLOGY

Waru Teknikatama designs and fabricates heat exchangers, pressure vessels and other equipment to accomplish highest degree of client satisfaction.

**Products** | Air Cooled Heat Exchangers | Shell & Tube Heat Exchangers | Pressure Vessels | Plate Heat Exchangers | Other Equipment

**Services** | Heat transfer related calculation, design and development & troubleshooting | Detail Design Packages : Mechanical, Civil, Electrical Engineering design of plant | After Sales Services by providing spare parts and special tools for heat exchangers

### Codes & Standards

- Pressure Vessel : ASME Sec VIII Div 1&2, PD 550
- ACHE : API 661, ASME Sec VIII Div 1
- STHE : TEMA, API 660, ASME Sec VIII Div 1&2
- Storage Tank : API 650, API 620, AWWA D100
- Piping System : ASME Sec I, ASME B31.3, B31.4, B31.8
- Condenser : HEI (Heat Exchanger Institute)
- LP Heater
- HP Heater
- Deaerator

### Certifications

- ASME U, U2, S
- The National Board of Boiler and Pressure Vessel Inspectors (NB & R)
- ISO 9001 : 2008
- HTRI Member



### Head Office

Unimas Garden Regency  
 Jl. Imermotors F-18  
 Waru, Sidoarjo 61256 – Indonesia  
 Phone : +62 (0) 31 853 3643,  
 853 3591, 854 9184  
 Fax : +62 (0) 31 853 3591  
 www.waruteknikatama.com  
 waru@waruteknikatama

### Workshop

Desa Domas. Km 11, Trowulan, Mojokerto, East Java, Indonesia



Cert.No. JKT 6006851



ASME - S AND U Stamp

are directed to sulfur recovery units with a chamber to convert the  $\text{NH}_3$  to  $\text{N}_2$ , this is necessary to avoid that the  $\text{NH}_3$  prejudice the  $\text{H}_2\text{S}$  conversion in elemental sulfur through Claus process.

Initially, the designs predict to send the sour gas to burn in fired heaters, like in distillation units. Nowadays, with the environmental restrictions and the necessity to reduce  $\text{SO}_x$  and  $\text{NO}_x$  emissions the project concept were changed and the sour gases are directed to sulfur recovery units with a chamber to convert the  $\text{NH}_3$  to  $\text{N}_2$ , this is necessary to avoid that the  $\text{NH}_3$  prejudice the  $\text{H}_2\text{S}$  conversion in elemental sulfur through Claus process.

The modern designs rely upon the installation of two towers, one for the  $\text{H}_2\text{S}$  removal and the second for the  $\text{NH}_3$  removal like described in Figure 3.

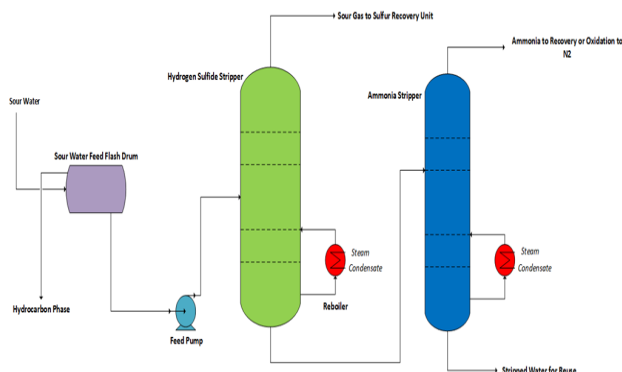

Figure 3 – Typical Arrangement for Sour Water Stripping Unit with Two Towers

For units with two towers, the  $\text{H}_2\text{S}$  rectifier operates under pressures about 5 to 11  $\text{kgf/cm}^2$ , while the ammonia rectifier operates under pressures about 1 to 2  $\text{kgf/cm}^2$

The arrangement with two towers show some advantages in relation to the project with a single tower, once that allows higher recovery of  $\text{H}_2\text{S}$  like elemental sulfur, reducing the  $\text{SO}_x$  emissions. Furthermore, the design with two towers allows recover the ammonia present in the sour water or converts this stream to  $\text{N}_2$ .

As a disadvantage in comparison with the single tower design, we can mention the higher initial investment, higher energy consumption and increased operational complexity.

A very important equipment in these processes units are the feed drum or, in some cases, the feed tank. This equipment will provide the necessary residence time to promote the water/oil separation, if this time was quite low the sour water will drag oil to the stripping tower and the process can become unstable and inefficient.

### **Available Technologies**

There are some licensors that engage his efforts to develop efficient technologies to improve the quality of the sour water stripping units. An example is the GTC Technology Company which licenses the process called GT-SWS™, this process can apply single or two towers according to the design case. The JACOBS Company licenses the COMPRIMO™ process that normally applies a single tower to treat the sour water.

The CHEVRON Company developed the WWT™ process that is currently licensed by BECHTEL Company, this process applies two towers and can produce relatively pure ammonia and hydrogen sulfide.

### **Conclusion**

As aforementioned the pressure upon refiners to reduce the environmental impact of his processes is increasingly higher. In this scenario, environmentally friendly processes like sour water stripping are fundamental to the crude oil refining chain.

### **References**

- MYERS, R.A. *Handbook of Petroleum Refining Processes*. 3<sup>rd</sup> ed. McGraw-Hill, 2004.
- FAHIM, M.A.; AL-SAHHAF, T.A.; ELKILANI, A.S. *Fundamentals of Petroleum Refining*. 1<sup>st</sup> ed. Elsevier Press, 2010.



### About the Author : Biography

Dr. Marcio Wagner da Silva is Process Engineer and Project Manager focusing on Crude Oil Refining Industry based in São José dos Campos, Brazil. Bachelor in Chemical Engineering from University of Maringa (UEM), Brazil and PhD. in Chemical Engineering from University of Campinas (UNICAMP), Brazil. Has extensive experience in research, design and construction to oil and gas industry including developing and coordinating projects to operational improvements and debottlenecking to bottom barrel units, moreover Dr. Marcio Wagner have MBA in Project Management from Federal University of Rio de Janeiro (UFRJ) and is certified in Business from Getulio Vargas Foundation (FGV).

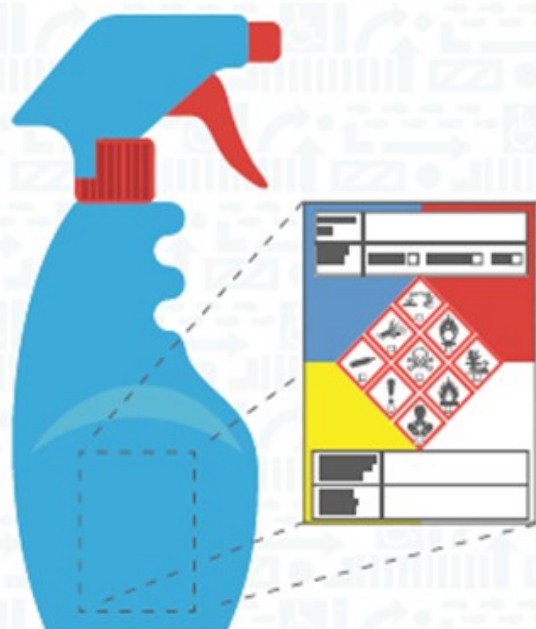

Shop GHS Secondary Labels

## GHS REQUIREMENTS ARE CONFUSING

BUT THEY DON'T NEED TO BE

OUR SYSTEM INCLUDES:

- Simple SDS to GHS transfer
- HAZCOM training video
- HAZCOM written program

**WE MAKE COMPLIANCE EASY**

FOR MORE INFO VISIT  **Stop-Painting.com**

OR CALL: (919) 569-6765



Floor Marking Tape



Floor Signs



X, L, T Markers



Pavement Markings



SEPTEMBER 25 - 27, 2018

Telus Convention Centre | Calgary, Canada

**The World's Pipeline Industry Meets Here.**



**[www.internationalpipelineexposition.com](http://www.internationalpipelineexposition.com)**

For exhibit and sponsorship opportunities,

Contact Stephen Furze, Sales Manager,

(403) 444-6529, [stephenfurze@dmgevents.com](mailto:stephenfurze@dmgevents.com)



## Quarterly Safety Connector



*For Engineers; Because Safety Is Part Of The Process!*

By: Chris Palmisano, MESH, IFSAC January 2018

# OSHA's Top 25 Areas of Focus In An Inspection!



I'm sharing my OSHA Compliance Officer Inspection Checklist with you all, to help you get your companies in compliance and prepare you for those pesky OSHA inspections. Don't forget, if it's not documented, it didn't happen!

I believe it was Louis Pasteur that said, "Chance favors the prepared mind". Simply, be prepared for a Regulatory Inspection; they are prepared, why not you too?

1. Housekeeping/clutter (are they cooperative)?
2. Condition of facility or job-site (Are they Insured)?
3. OSHA 300 logs for the last 5 years and DART rate?
4. Written Safety Policies (yes) or (no)
5. Records of Training & Do they have Tool Box Talks?
6. Do they have a Safety Committee? Do they keep meeting minutes?
7. Written Emergency Evacuation Plan (yes) or (no)
8. Records of fire drills (yes) or (no)
9. Do they have an internal Emergency Response Team (yes) or (no)

10. Extinguisher/eyewash/shower/emergency lighting inspections records (yes) or (no)
11. PPE/JHA Job Hazard Assessments (yes) or (no)
12. Maps/Site layout (evacuation maps posted) each floor (yes) or (no)
13. Boiler and Pressure Vessel certifications if >(5 cubic feet or larger) or (37 1/2 gallons). (yes) or (no)
14. Square footage of the facility/job-site
15. Hazcom program, including SDS's available for employees, a workplace labeling program, a Chemical Inventory & are employees trained on the new GHS labeling elements?
16. Forklift inspections and training records (are employees certified)?
17. Lockout-Tagout Program / procedures, training (singularly identifiable locks) (yes) or (no)
  - a) Are all machine safety features tested and functioning (yes) or (no)
  - b) Are all Machines, Rotating Shafts, Nip & Pinch Points of operation guarded? (yes) or (no)
18. Are there any Confined Spaces (yes) or (no)
19. Blood-borne Pathogen Program (yes) or (no)
20. Hearing Conservation Program (if applicable)
21. Process safety program (if applicable)
22. Does the employer conduct/document frequent and regular inspections? (yes) or (no)
23. New & Temporary Employee safety training program? (yes) or (no)
24. Total # of employees corporate wide, and at the site they are inspecting \_\_\_\_\_ NOTE: These numbers determine fine discounts after citations are issued.
25. How many shifts operate and are they Full-Time/Part-Time/Pool-Staff (Temps)

Chris is a Professional Risk Management Consultant, a former Philadelphia Fire Department Lieutenant and former OSHA Compliance Officer. He is the creator of the InSite GHS Hazcom Workplace Labeling System for Secondary Chemical Containers. For questions about this article or his workplace chemical labeling system to meet the OSHA GHS June 2016 requirement, you can reach Chris at: ChrisAPal@aol.com or at LinkedIn <https://www.linkedin.com/in/chris-palmisano-696b3b6/>

# EMPOWERING PROCESS SIMULATION



**Improve the past.  
Optimize the present.  
Design the future.**

VISIT

[virtualmaterials.com/GetVMGSim](http://virtualmaterials.com/GetVMGSim)  
to find out more.

As a process engineer you need innovative tools to see your vision come to life.

VMGSim™ is a comprehensive steady state and dynamic process simulator that provides flexibility and control to help design new processes and improve your existing plant's efficiency and bottom line.

Our PIONA molecular structure based oil characterization system allows high fidelity modelling of light to heavy hydrocarbons from the gathering system to refinery products and distribution.



U.S. • Canada • Japan • Europe • Australasia • Egypt • China • Middle East • Brazil



**IACPE**  
INTERNATIONAL ASSOCIATION OF  
CERTIFIED PRACTICING ENGINEERS

[www.iacpe.com](http://www.iacpe.com)

